

# CR-H, CRN-H, CRE-H, CRNE-H

Horizontal end-suction multistage centrifugal pumps  
North America, 60 Hz



be  
think  
innovate

**GRUNDFOS** 

<b>1. Product introduction</b>	<b>4</b>	<b>11. Operating conditions</b>	<b>36</b>
Features and benefits	4	Pumped liquids	36
Selecting a CRE-H, CRNE-H pump	5	List of pumped liquids	36
Pump	5	Operating range of the shaft seal	40
Motors	6	Maximum inlet pressure	41
Terminal box positions	9		
Viscosity	9	<b>12. Selection and sizing</b>	<b>42</b>
Ambient temperature and altitude	9	Selection of pumps	42
Installation altitude	10	Minimum inlet pressure, NPSHA	45
		How to read the curve charts	46
<b>2. Applications</b>	<b>11</b>	Guidelines to performance curves	47
<b>3. Application example for constant differential pressure in a circulation system<sup>12</sup></b>		<b>13. Curve charts/technical data</b>	<b>48</b>
Constant differential pressure, pump	12	CR, CRN 1s H GA	48
Proportional differential pressure	12	CR, CRE, CRN, CRNE 1 H GA	50
Proportional differential pressure, parabolic (proportional differential pressure available on CRE-DP only)	13	CR, CRE, CRN, CRNE 3 H GA	52
Constant differential pressure	13	CR, CRE, CRN, CRNE 5 H GA	54
Proportional differential pressure	13	CR, CRE, CRN, CRNE 10 H G22	56
		CR, CRE, CRN, CRNE 10 H GA/G05	58
<b>4. Performance range</b>	<b>14</b>	CR, CRE, CRN, CRNE 15 H G22	61
CR-H, CRN-H	14	CR, CRE, CRN, CRNE 15 H GA/G05	63
CRE-H, CRNE-H	14	CR, CRE, CRN, CRNE 15 H GB	66
		CR, CRE, CRN, CRNE 20 H G22	68
<b>5. Product range</b>	<b>15</b>	CR, CRE, CRN, CRNE 20 H GA/G05	70
		CR, CRE, CRN, CRNE 20 H GB	73
<b>6. Identification</b>	<b>16</b>	CR, CRE, CRN, CRNE 32 H G22	75
Type key	16	CR, CRE, CRN, CRNE 32 H GA/G05	77
Codes	16	CR, CRE, CRN, CRNE 32 H GB/G50	80
		CR, CRE, CRN, CRNE 32 H GC/G10/G60	83
<b>7. MLE technical data</b>	<b>17</b>	CR, CRE, CRN, CRNE 45 H G33	87
MLE permanent-magnet motors 1/2 - 2 HP	17	CR, CRE, CRN, CRNE 45 H GB/G20/G50	89
MLE permanent-magnet motors 1-15 HP	18	CR, CRE, CRN, CRNE 45 H GC/G10/G30/G60	93
MLE permanent-magnet motors 1 1/2 - 7 1/2 HP	19	CR, CRE, CRN, CRNE 64 H G44	98
MLE asynchronous motors 20-30 HP	20	CR, CRE, CRN, CRNE 64 H GC/G10/G30/G60	100
MLE motors for CRE-H and CRNE-H	21	CR, CRE, CRN, CRNE 64 H G20/G50	105
		CR, CRE, CRN, CRNE 64 H G40/G70	108
<b>8. Control of E-pumps</b>	<b>22</b>	CR, CRN 90 H G44	111
Examples of E-pump applications	22	CR, CRN 90 H G20	113
Control options	23	CR, CRN 90 H G30/G60	115
Control modes for E-pumps	24	CR, CRN 90 H G40/G70	118
		<b>14. Motor data</b>	<b>121</b>
<b>9. Advanced use of MLE motors</b>	<b>26</b>	Motors for CR(E)-H, CRN(E)-H	121
Introduction	26		
Bearing monitoring	26	<b>15. Accessories</b>	<b>124</b>
Standstill heating	26	Baseplate	124
Outdoor installation	27	Pipe connection	128
Stop function	27	LiqTec	129
Temperature sensors 1 and 2	28	Pressure sensor	132
Signal relays	29	Pressure sensor	133
Analog sensor inputs 1 and 2	30	Grundfos differential-pressure sensor, DPI	134
Limit exceeded 1 and 2	31	Grundfos differential-pressure sensor, DPI g.2 version	136
		Flow transmitters	138
<b>10. Construction</b>	<b>34</b>	Gauges for CRE, CRIE, CRNE	138
CR, CRE 1s, 1, 3, 5, 10, 15 and 20 H	34	Remote controls	139
CRN, CRNE 1s, 1, 3, 5, 10, 15 and 20 H	34	CIU communication interface units	140
CR, CRE 32, 45, 64, and 90 H	35	CIM communication interface modules	140
CRN, CRNE 32, 45, 64, and 90 H	35	MP 204 motor protector	141

<b>16. Variants</b>	<b>142</b>
Lists of variants on request	142
Motors	142
Connections and other variants	142
Shaft seals	142
Pumps	142
<b>17. Grundfos Product Center</b>	<b>143</b>
Grundfos GO	144
<b>18. Submittal data</b>	<b>145</b>
<b>19. Quotation text</b>	<b>146</b>

# 1. Product introduction

This product guide deals with CR-H and CRN-H horizontal end-suction pumps as well as CRE-H and CRNE-H pumps.

## Features and benefits

### CR-H, CRN-H



Fig. 1 CR-H pumps

CR-H, CRN-H pumps are horizontal end-suction pumps typically mounted on baseplates. The end-suction design enables the pump to be installed horizontally in traditional, end-suction design pipes where the pump has an axial inlet port and a radial center line outlet port. This design allows "back pull-out" capability so that most models can be serviced without removing the volute from the pipe system.

Grundfos CR-H, CRN-H pump range includes various pump sizes and various numbers of stages to provide the flow rate and the pressure required.

CR-H, CRN-H pumps are suitable for a variety of applications from pumping of potable water to pumping of chemicals. The pumps are therefore used in a wide variety of pumping systems where the performance and material of the pump meet specific demands.

The CR-H, CRN-H pumps consist of three main components: the motor, the pump unit, and the baseplate.

The pump unit consists of optimized hydraulics, various flange connections, a pump head, an end-suction volute, and various other parts.

CR-H, CRN-H pumps are available in various material versions according to the pumped liquid.

CR-H, CRN-H pumps can be selected that meet ASME B73.1 dimensional standards for inlet and outlet pipes as well as many of the baseplate dimensional standards. **CR-H, CRN-H pumps do not fully comply with the ASME B73.1 specification.**

There is also a full range of CR-H, CRN-H pumps with standard Grundfos connection sizes that are optimized to give greater performance and efficiency.

### CRE-H, CRNE-H



Fig. 2 CRE-H pumps

CRE-H, CRNE-H pumps are built on the basis of CR-H, CRN-H pumps. CRE-H, CRNE-H pumps belong to the so-called E-pump family and are referred to as E-pumps. The difference between the CR-H, CRN-H and the CRE-H, CRNE-H pump range is the motor. CRE-H, CRNE-H pumps are fitted with an E-motor with built-in frequency control. The CRE-H, CRNE-H pump has a Grundfos MLE motor.

The built-in variable frequency drive enables continuously variable control of the motor speed.

This means that the pump can be set to operate at any duty point. The purpose of continuously variable speed control of the motor speed is to adjust the performance to a given requirement.

CRE-H, CRNE-H pumps are available with a pressure sensor enabling the control of the pressure on the outlet side of the pump.

The purpose of supplying the E-pumps with a pressure sensor is to make the installation and commissioning simple and quick. All other E-pumps are supplied without sensor.

E-pumps without sensor are used when uncontrolled operation (open loop) is required or when there is a wish to fit a sensor at a later stage in order to enable:

- Pressure control
- flow control
- level control of liquid in a tank
- temperature control
- differential pressure control
- differential temperature control.

TM04 3882 0710

TM04 4177 0909

E-pumps without sensor are also used when a remote analog signal is connected to the setpoint input terminal.

An E-pump is not just a pump, but a system which is able to solve application problems or save energy in a variety of pump installations. All that is required, is the power supply connection and the fitting of the E-pump in the pipe system, and the pump is ready for operation.

The pump has been tested and pre-configured from the factory. The operator only has to specify the desired setpoint (pressure) and the system is operational.

The pump materials are the same as those of the CR-H, CRN-H.

In new installations, the E-pumps provide a number of advantages. The integrated variable frequency drive has a built-in motor protection function which protects both motor and electronics against overload. This means that E-pump installations do not require a motor-protective circuit breaker, but only a normal short circuit protection for the cable.

## Selecting a CRE-H, CRNE-H pump

Select a CRE-H, CRNE-H pump if:

- Controlled operation is required, i.e. consumption fluctuates.
- Constant pressure is required.
- Communication with the pump is required.

Adaptation of performance through frequency-controlled speed control offers obvious advantages:

- energy savings
- increased comfort
- control and monitoring of the pump performance.

See pages 17-33 for more information about E-pumps.

## Pump

The CR-H, CRN-H pump is a non-self-priming, horizontal, end-suction, multistage centrifugal pump with enclosed impellers. The pumps are available with a Grundfos standard motor (CR-H, CRN-H pumps) or a frequency-controlled motor (CRE-H, CRNE-H pumps).

The pump consists of a volute and a pump head. The chamber stack and the outer sleeve are secured between the pump head and the volute by means of staybolts. The volute has an end-suction port and vertical centerline outline port.

All pumps are equipped with a maintenance-free mechanical shaft seal of the cartridge type.

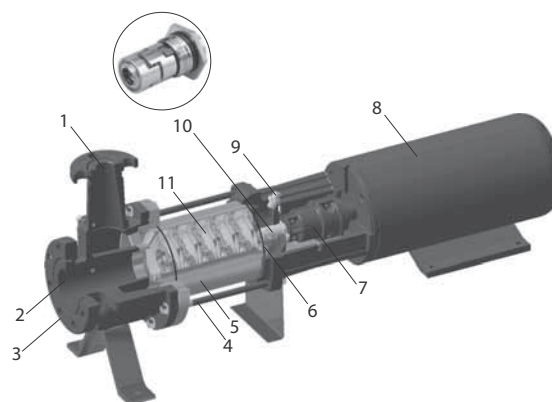

TM04 4161 0510

Fig. 3 CR-H pump

### CR-H components

Pos.	Designation
1	Outlet
2	Inlet
3	Flange
4	Staybolts
5	Outer sleeve
6	O-ring
7	Coupling
8	Motor
9	Priming plug
10	Shaft seal
11	Impellers

## Motors

### Grundfos standard motors

#### ML (through 30 HP) and Baldor® (40 HP and larger) motors

CR-H, CRN-H pumps are fitted with a Grundfos specified motor. The motors are all heavy-duty 2-pole, NEMA C-face motors with feet. Three-phase motors greater than 3/4 HP are Premium efficient at minimum.

#### Frequency-controlled motors - MLE motors

MLE motors incorporate thermal protection against slow overload and blocking.

CRE-H, CRNE-H pumps require no external motor protection.

Frequency-controlled MLE motors

CRE-H, CRNE-H pumps are fitted with a totally enclosed, fan-cooled, frequency-controlled MLE motor.

Permanent-magnet motors

From 1/2 to 2 HP Grundfos offers CRE-H, CRNE-H pumps fitted with single-phase MLE motors (1 x 200-240 V).

From 1 to 15 HP Grundfos offers CRE-H, CRNE-H pumps fitted with three-phase MLE motors (3 x 440-480 V).

From 1 1/2 to 7 1/2 HP, Grundfos offers CRE-H, CRNE-H pumps fitted with three-phase MLE motors (3 x 200-240 V).

Asynchronous motors

From 20 to 30 HP Grundfos offers CRE-H, CRNE-H pumps fitted with three-phase MLE motors (3 x 460-480 V).

See Grundfos Product Center at [www.grundfos.com](http://www.grundfos.com).

## Electrical data and approvals

### CR-H, CRN-H

Mounting designation	NEMA
Insulation class	F & B
Efficiency class	<ul style="list-style-type: none"> <li>• <b>Standard efficiency</b> - single-phase</li> <li>• <b>Premium efficiency</b> - three-phase Grundfos ML and Baldor motors</li> </ul>
Enclosure class	TEFC - Totally Enclosed Fan Cooled (Grundfos standard) ODP - Open Drip Proof - on request
60 Hz standard voltages	1 x 115/208-230 V 3 x 208-230/460 V 3 x 575 V

Baldor



ML/MLE\*

#### Approvals



MLE\*\*



\* Includes MLE motors 10 HP and smaller.

\*\* Includes MLE motors 15 HP and larger.

**Note:** CR-H pump with ANSI/NSF 61 listing is available. See UL file MH26400 or contact Grundfos.

### CRE-H, CRNE-H

	MLE motor CRE-H, CRNE-H
Mounting designation	NEMA
Insulation class	F
Efficiency	See page 121, Motor Data.
Enclosure class	TEFC (Totally Enclosed Fan Cooled)
	1/2 to 2 HP 1 x 200-240 V
	1 to 15 HP: 3 x 440-480 V
Supply voltage	
Tolerance: - 10 %/+ 10 %	20 to 30 HP: 3 x 460-480 V
	1 1/2 to 7 1/2 HP: 3 x 200-240 V

### MLE 1/2 to 15 HP permanent-magnet motors

**Supply voltage:**

1/2 to 2 HP (1 x 200-240 V)

1 to 15 HP (3 x 440-480 V)

1 1/2 to 7 1/2 HP (3 x 200-240 V)

Advanced functional module (FM 300)

The FM 300 is the standard functional module in all MLE motors 1/2 to 15 HP.

The module has a number of inputs and outputs enabling the motor to be used in advanced applications where many inputs and outputs are required.

The FM 300 has these connections:

- three analog inputs
- one analog output
- two dedicated digital inputs
- two configurable digital inputs or open-collector outputs
- Grundfos Digital Sensor input and output
- two Pt100/1000 inputs
- two LiqTec sensor inputs
- two signal relay outputs
- GENIbus connection.

**Connection terminals**

CRE-H, CRNE-H pumps have a number of inputs and outputs enabling the pumps to be used in advanced applications where many inputs and outputs are required.

Functional module 300 has been selected as standard for CRE-H, CRNE-H pumps.

See fig. 4.

As a precaution, the wires to be connected to the following connection groups must be separated from each other by reinforced insulation in their entire lengths.

**Inputs and outputs**

- Start/stop (digital input 1) (terminals 2 and 6)
- pressure sensor (analog input 1) (terminals 4 and 8)
- pressure switch (digital input 3) (terminals 10 and 6)
- external analog signal input (analog input 2) (terminals 7 and 23)
- GENIbus (terminals A, Y and B).

All inputs and outputs are internally separated from the power-conducting parts by reinforced insulation and galvanically separated from other circuits.

All control terminals are supplied by protective extra-low voltage (PELV), thus ensuring protection against electric shock.

**Signal relay outputs**

– Signal relay 1:

LIVE:

Power supply voltages up to 250 VAC can be connected to this output.

PELV:

The output is galvanically separated from other circuits. Therefore, the supply voltage or proactive extra-low voltage can be connected to the output as desired.

– Signal relay 2:

PELV:

The output is galvanically separated from other circuits. Therefore, the supply voltage or proactive extra-low voltage can be connected to the output as desired.

– **Power supply** (terminals N, PE, L or L1, L2, L3, PE)

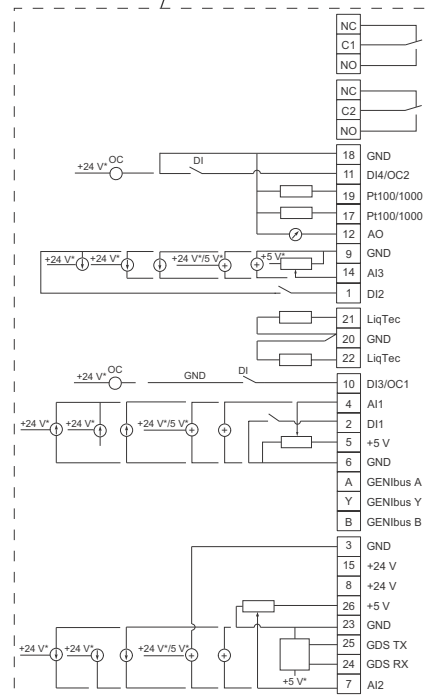
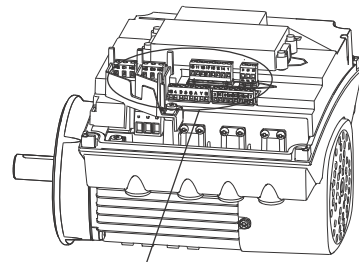

\* If an external supply source is used, there must be a connection to GND.

**Fig. 4** Connection terminals, FM 300 functional module

TMM05 3509 3512

## MLE 20 to 30 HP asynchronous motors

**Supply voltage:**  
20 to 30 HP (3 x 460-480 V)

### Advanced I/O module

The advanced I/O module is the standard functional module in these MLE motors.

The module has a number of inputs and outputs enabling the motor to be used in advanced applications where many inputs and outputs are required.

The Advanced I/O module has these connections:

- start/stop terminals
- three digital inputs
- one setpoint input
- one sensor input (feedback sensor)
- one sensor 2 input
- one analog output
- two Pt100 inputs
- two signal relay outputs
- GENIbus connection.

### Connection terminals

As a precaution, the wires to be connected to the following connection groups must be separated from each other by reinforced insulation in their entire lengths.

### Inputs and outputs

- Start/stop (terminals 2 and 3)
- digital inputs (terminals 1 and 8, 10 and 8, 11 and 9)
- sensor input 2 (terminals 14 and 15)
- Pt100 sensor inputs (terminals 17, 18, 19 and 20)
- setpoint input (terminals 4, 5 and 6)
- sensor input (terminals 7 and 8)
- GENIbus (terminals B, Y and A).

All inputs are internally separated from the power-conducting parts by reinforced insulation and galvanically separated from other circuits.

All control terminals are supplied with protective extra-low voltage (PELV), thus ensuring protection against electric shock.

### Output (relay signal, terminals NC, C, NO)

The output is galvanically separated from other circuits.

Therefore, the supply voltage or protective extra-low voltage can be connected to the output as desired.

- Analog output (terminal 12 and 13).

### Power supply (terminals L1, L2, L3)

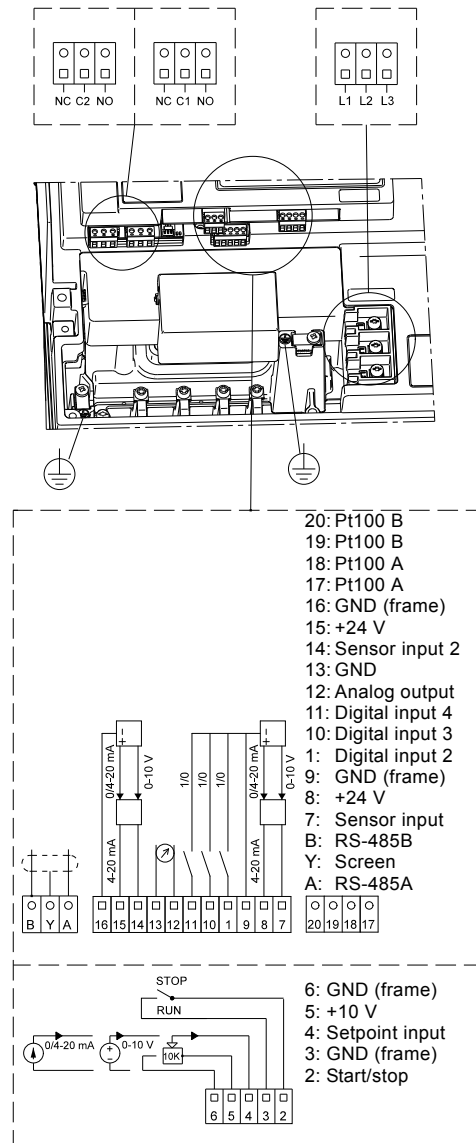

Fig. 5 Connection terminals, Advanced I/O module

TM05 7035 0313

### Optional motors

The Grundfos standard range of motors covers a wide variety of application demands. However, for special applications or operating conditions, custom-built motor solutions can be provided.

For special applications or operating conditions, Grundfos offers custom-built motors such as:

- explosion-proof motors
- motors with anti-condensation heating unit
- low-noise motors
- energy efficient and premium efficiency motors
- motors with thermal protection.

### Motor protection

Single-phase Grundfos specified motors up to 3/4 HP have a built-in thermal overload switch.

Three-phase motors **must** be connected to a motor-protective circuit breaker in accordance with local regulations.

### MLE motors

CRE-H, CRNE-H pumps require no external motor protection. The MLE motor incorporates thermal protection against slow overloading and blocking.

### Terminal box positions

As standard the terminal box is mounted as shown in fig. 6.

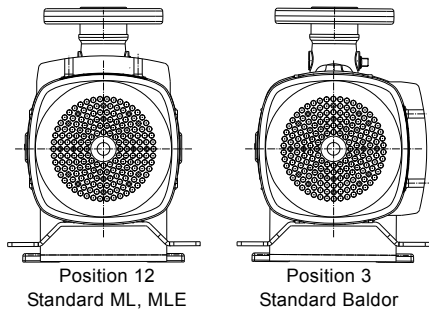

Fig. 6 Terminal box positions

### Viscosity

The pumping of liquids with densities or kinematic viscosities higher than those of water will cause a considerable pressure drop, a drop in the hydraulic performance and a rise in the power consumption.

In such situations, the pump must be equipped with a larger motor. For selection you may utilize the Grundfos Product Center at [www.grundfos.com](http://www.grundfos.com). If in doubt, contact Grundfos.

### Ambient temperature and altitude

If the ambient temperature exceeds the maximum temperature limits of the motor or the pump is installed at an altitude exceeding the altitude values in the chart below (3280 ft (1000 m)), the motor must not be fully loaded due to the risk of overheating.

Overheating may result from excessive ambient temperatures or the low density and consequently low cooling effect of the air at high altitudes. In such cases, it may be necessary to use a motor with a higher rated output ( $P_2$ ).

See also [Installation altitude](#) on page 10.

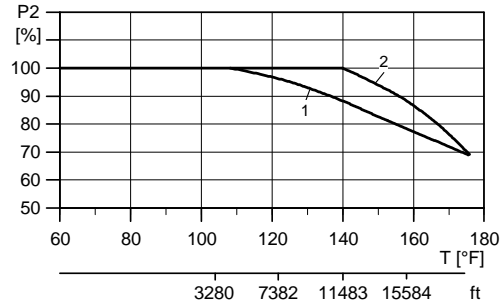

Fig. 7 Relationship between motor output ( $P_2$ ) and ambient temperature/altitude

### Legend

Pos.	Description
1	NEMA energy efficient motors (EPAct)
2	NEMA Premium efficiency motors

**Example:** From fig. 7 it appears that  $P_2$  must be reduced to 88 % when a pump with a NEMA Premium efficiency, ML motor is installed 15,584 feet above sea level. At an ambient temperature of 167 °F,  $P_2$  of an energy efficient motor must be reduced to 74 % of rated output.

MLE motor power [HP (kW)]	Motor make	Voltage [V]	Max. ambient temp. [°F (°C)]	Max. altitude above sea level [ft (m)]
1/2 to 2 (0.37 to 1.5)	MLE	1 x 200-240	122 (50)	3280 (1000)
1 to 15 (0.74 to 11.18)	MLE	3 x 440-480	122 (50)	
1 1/2 to 7 1/2 (1.1 to 5.5)	MLE	3 x 200-240	104 (40)	
20 to 30 (14.91 to 22)	MLE	3 x 460-480	104 (40)	

TM02 1805 2001

TM03 4272 2006

## Installation altitude

Installation altitude is the height above sea level of the installation site. Motors installed up to 3280 ft (1000 m) above sea level can be loaded 100 %.

Motors installed more than 3280 ft (1000 m) above sea level must not be fully loaded due to the low density and consequently low cooling effect of the air.

### MLE permanent-magnet motors

1/2 to 2 HP (1 x 200-240 V)

1 to 15 HP (3 x 440-480 V)

1 1/2 to 7 1/2 HP (3 x 200-240 V)

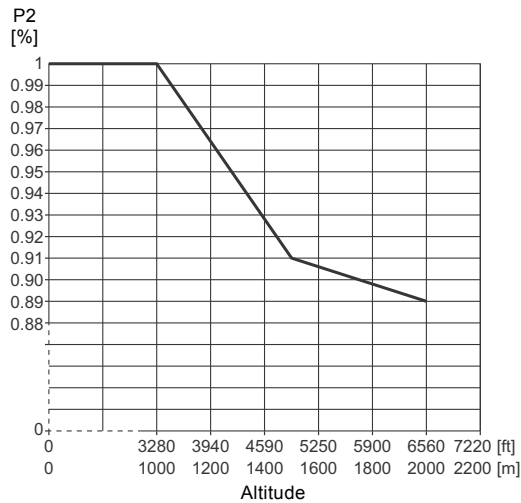

TM05 9217 3513

**Fig. 8** Derating of motor output (P2) in relation to altitude above sea level

### MLE asynchronous motors

20 to 30 HP (3 x 460-480 V)

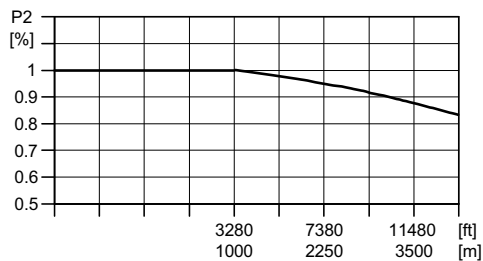

TM05 9218 3513

**Fig. 9** Derating of motor output (P2) in relation to altitude above sea level

## 2. Applications

Application	CR-H	CRN-H	CRE-H, CRNE-H
<b>Water supply</b>			
Filtration and transfer at waterworks	•	○	•
Distribution from waterworks	•	○	•
Pressure boosting in mains	•	○	•
Pressure boosting in high-rise buildings, hotels, etc.	•	○	•
Pressure boosting for industrial water supply	•	○	•
<b>Industry</b>			
<b>Pressure boosting...</b>			
process water systems	•	•	•
washing and cleaning systems	•	•	•
vehicle washing tunnels	•	○	•
fire fighting systems	•		
<b>Liquid transfer...</b>			
cooling and air-conditioning systems (refrigerants)	•	○	•
boiler feed and condensate systems	•	○	•
machine tools (cooling lubricants)	•	•	•
aquafarming	•	○	
<b>Special transfer duties...</b>			
oils and alcohols	•	•	•
acids and alkalis		•	
glycol and coolants	•	•	•
<b>Water treatment</b>			
Ultrafiltration systems		•	•
Reverse osmosis systems		•	•
Softening, ionizing, demineralizing systems		•	•
Distillation systems		•	•
Separators	•	•	•
Swimming pools		•	•
<b>Irrigation</b>			
Field irrigation (flooding)	•	○	
Sprinkler irrigation	•	○	•
Drip-feed irrigation	•	○	

- Recommended version.
- Alternative version.

### 3. Application example for constant differential pressure in a circulation system

Circulation systems (closed systems) are well-suited for speed-controlled pump solutions.

It is an advantage that circulation systems with variable system characteristic are fitted with a differential-pressure-controlled circulator pump. See fig. 10.

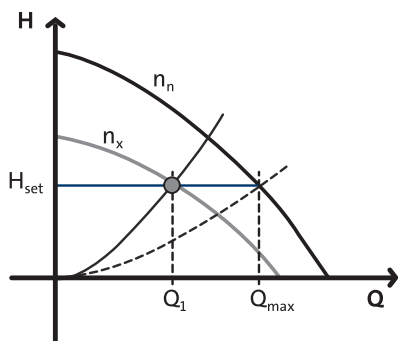
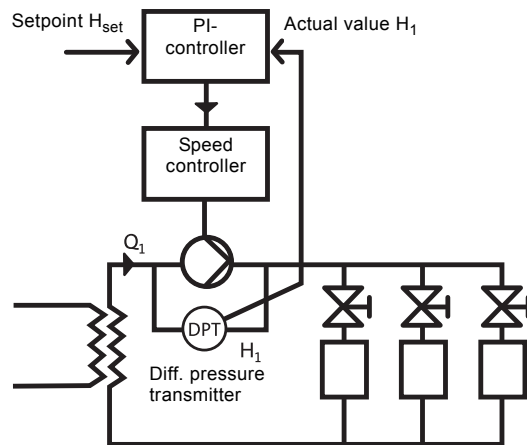

Fig. 10 Constant differential-pressure control

Figure 10 shows a heating system consisting of a heat exchanger where the circulated water is heated and delivered to three radiators by a speed-controlled pump. A control valve is connected in series at each radiator to control the flow according to the heat requirement.

The pump is controlled according to a constant differential pressure measured across the pump. This means that the pump system offers constant differential pressure in the  $Q$  range of 0 to  $Q_{max}$ , represented by the horizontal line in fig. 10.

#### Constant differential pressure, pump

The differential pressure of the pump is kept constant, independently of the flow rate. See fig. 11.

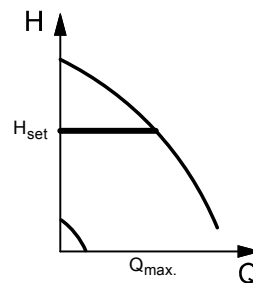

Fig. 11 Constant differential pressure, pump

The pump is controlled according to a constant differential pressure measured across the pump. This means that the pump system offers constant differential pressure in the  $Q$ -range of 0 to  $Q_{max}$ , represented by the horizontal line in the QH diagram.

#### Proportional differential pressure

The differential pressure of the pump is reduced at falling flow rate and increased at rising flow rate. See fig. 12.

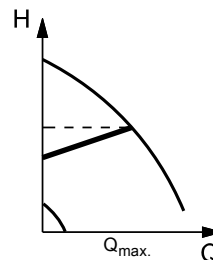

Fig. 12 Proportional differential pressure

The pump is controlled according to a differential pressure measured across the pump. This means that the pump system offers a proportional differential pressure in the  $Q$ -range of 0 to  $Q_{max}$ , represented by the sloping line in the QH diagram.

### Proportional differential pressure, parabolic (proportional differential pressure available on CRE-DP only)

Setting via PC Tool.

The proportional differential pressure can be selected with one of these flow dependencies:

- linear (setting via PC Tool).
- parabolic (setting via PC Tool).

When the flow dependency is selected as parabolic, the differential pressure of the pump will be reduced with a parabolic curve at falling flow rate and increased at rising flow rate. See fig. 13.

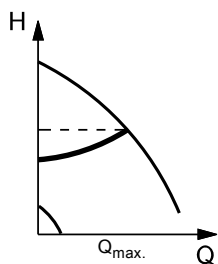

TM04 1695 0908

Fig. 13 Proportional differential pressure, parabolic curve

The pump is controlled according to a differential pressure measured across the pump. This means that the pump system offers a flow-compensated differential pressure in the Q-range of 0 to  $Q_{max}$ , represented by the parabolic curve in the QH diagram.

### Constant differential pressure

The setpoint range is between 12.5 % and 100 % of maximum head.

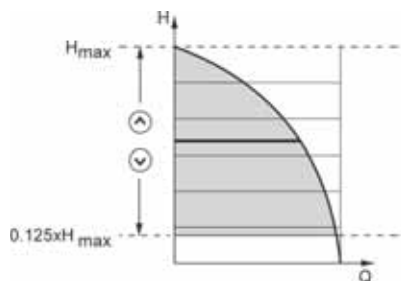

TM06 2408 1014

Fig. 14 Constant differential pressure

### Proportional differential pressure

The setpoint range is between 25 % and 90 % of maximum head.

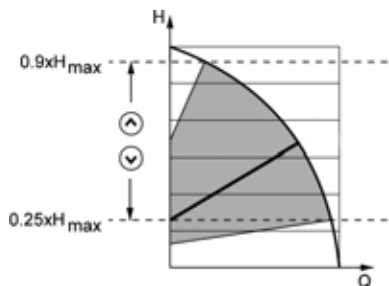

TM06 2479 1014

Fig. 15 Proportional differential pressure

To compensate for this excessive system pressure, the proportional-pressure function automatically adapts the setpoint to the actual flow rate.

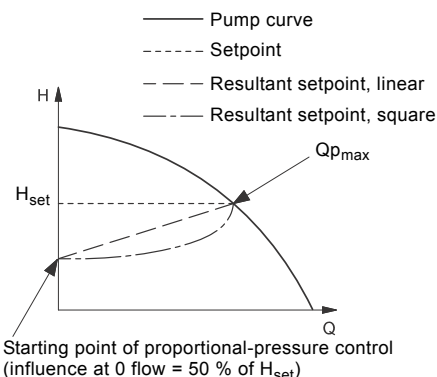

TM03 8524 2212

Fig. 16 Proportional-pressure control

The factory-fitted differential-pressure sensor is a variant. Contact Grundfos for additional details.

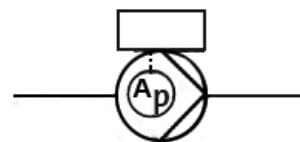

TM06 2478 1014

Fig. 17 Proportional pressure

# 4. Performance range

## CR-H, CRN-H

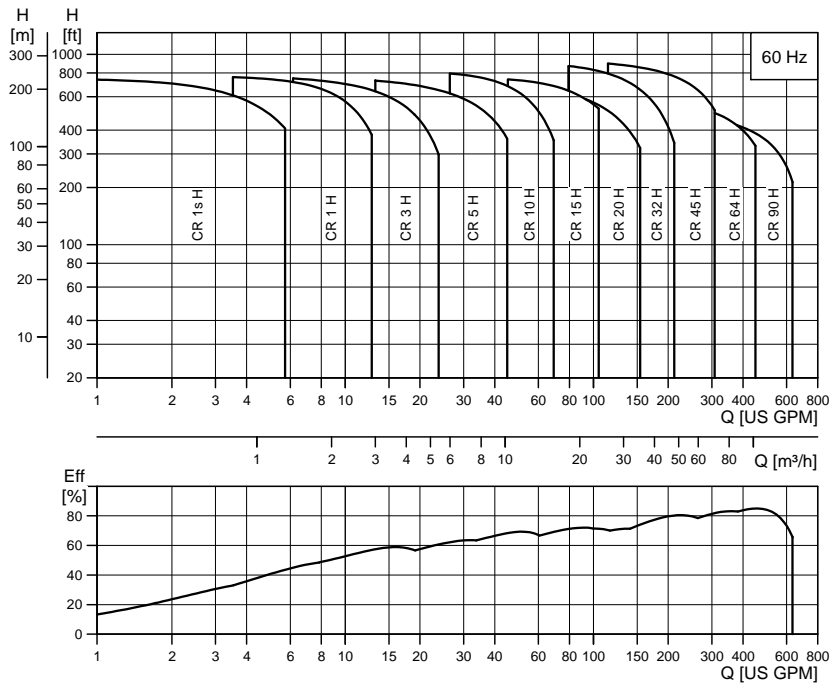

TM04 4552 1212

## CRE-H, CRNE-H

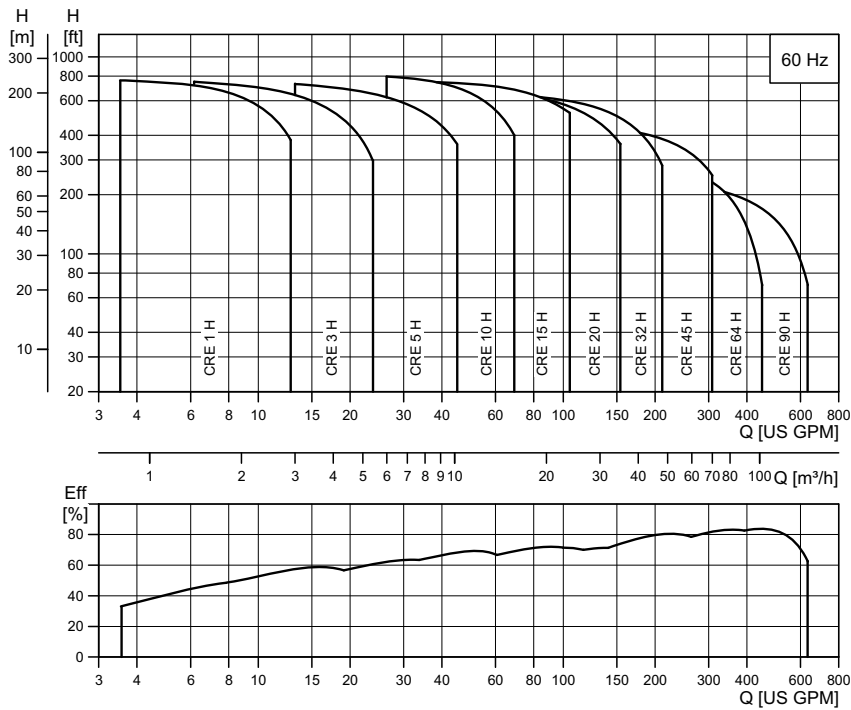

TM04 9018 1112

## 5. Product range

Range	CR, CRE 1s H	CR, CRE 1 H	CR, CRE 3 H	CR, CRE 5 H	CR, CRE 10 H	CR, CRE 15 H	CR, CRE 20 H	CR, CRE 32 H	CR, CRE 45 H	CR, CRE 64 H	CR 90 H	
Nominal flow rate [US GPM]	4.5	8.5	15	30	55	95	110	140	220	340	440	
Temperature range [°F]						-4 to +250						-22 to +250
Temperature range [°F] - on request						-40 to +356						-40 to +356
Maximum working pressure [psi]	360	360	360	360	360	360	360	435	435	435	435	
Maximum pump efficiency [%]	35	49	59	64	70	72	72	73	80	82	85	
<b>CR-H pumps</b>												
CR: Flow range [US GPM]	0.5 - 5.7	1 - 12.8	1.5 - 23.8	3-45	5.5 - 70	9.5 - 125	11-155	14-210	22-310	34-450	44-630	
CR: Maximum shut-off pressure (H [ft])	745	785	785	780	810	760	675	935	930	590	570	
CR: Motor power [HP]	1/3 - 2	1/2 - 3	1/2 - 5	3/4 - 7 1/2	3/4 - 15	2 - 25	3 - 25	3 - 50	7 1/2 - 60	7 1/2 - 60	15-60	
<b>CRE-H pumps</b>												
CRE: Flow range [US GPM]	0 - 5.7	0 - 12.8	0 - 23.8	0-45	0-70	0-125	0-155	0-210	0-310	0-450	0-630	
CRE: Maximum shut-off pressure (H [ft])	745	785	785	780	810	760	675	670	470	310	270	
CRE: Motor power [HP]	1/3 - 2	1/3 - 3	1/3 - 5	3/4 - 7.5	3/4 - 15	2 - 25	3 - 25	3 - 30	7 1/2 - 30	7 1/2 - 30	15-30	
<b>Version</b>												
CR-H, CRE-H versions: Cast iron and stainless steel AISI 304	•	•	•	•	•	•	•	•	•	•	•	
CRN-H, CRNE-H versions: Stainless steel AISI 316	•	•	•	•	•	•	•	•	•	•	•	
<b>CR-H, CRE-H pipe connection</b>												
ANSI connection type	GA	GA	GA	GA	G22*	G22*	G22*	G22*	G33*	G44*	G44*	
ANSI flange class [lb]	125/250	125/250	125/250	125/250	125/250	125/250	125/250	125/250	125/250	125/250	125/250	
<b>CRN-H, CRNE-H pipe connection</b>												
ANSI connection type	GA	GA	GA	GA	G22*	G22*	G22*	G22*	G33*	G44*	G44*	
ANSI flange class [lb]	150/300	150/300	150/300	150/300	150/300	150/300	150/300	150/300	150/300	150/300	150/300	
<b>Pipe connection - inlet x outlet x impeller size reference</b>												
GA ANSI 1.5" x 1" x 6", 1.5" x 1" x 8"	•	•	•	•	•	•	•	•				
G05 ANSI 2" x 1" x 10"					•	•	•	•				
GB ANSI 3" x 1.5" x 6", 3" x 1.5" x 8"						•	•	•	•			
GC ANSI 3" x 2" x 6"								•	•	•		
G10 ANSI 3" x 2" x 6"								•	•	•		
G50 ANSI 3" x 1.5" x 8", 3" x 1.5" x 10"								•	•	•		
G60 ANSI 3" x 2" x 8", 3" x 2" x 10"								•	•	•	•	
G20 ANSI 3" x 1.5" x 13"									•	•	•	
G30 ANSI 3" x 2" x 13"									•	•	•	
G70 ANSI 4" x 3" x 8", 4" x 3" x 10"										•	•	
G40 ANSI 4" x 3" x 10", 4" x 3" x 13"										•	•	
G22 ANSI 2" x 2"					•	•	•	•				
G33 ANSI 3" x 3"								•	•			
G44 ANSI 4" x 4"										•	•	

• Available

\* There are a variety of flange size options available for this size CR-H (see list above). Selection should be based on replacement size or choose listed size for new installations.

## 6. Identification

### Type key

#### CR-H, CRE-H

Example	CR E 5 s -4 -2 H -GA-G-E -HQQE
Type range	
Pump with integrated frequency control	
Rated flow rate [m <sup>3</sup> /h]	
All impellers with reduced diameter (applies only to CR, CRN 1s H)	
Number of impellers	
Number of reduced diameter impellers (applies only to CR, CR(E), CRN, CRN(E) 32, 45, 64, 90 H)	
Code for pump version	
Code for pipe connection	
Code for materials	
Code for rubber parts	
Code for shaft seal	

### Codes

Example	H -GA -A -E -H QQ E
<b>Pump version</b>	
HB Oversize motor	
HE Certificate/approval	
HF CR pump for high temperatures (air cooled top assembly)	
H Basic horizontal version	
HI Different pressure rating	
HJ Pump with different max speed	
HK Pump with low NPSH	
HM Magnetic drive	
HN Fitted with sensor	
HP Undersize motor	
HR Belt-driven pump	
HT Oversize motor (two flange sizes bigger) (two flange sizes bigger)	
X Special version <sup>1)</sup>	

#### Example H -GA -A -E -H QQ E

##### Pipe connection (inlet x outlet x impeller size reference)<sup>2)</sup>

GA	ANSI 1.5" x 1" x 6", 1.5" x 1" x 8"
G05	ANSI 2" x 1" x 10"
GB	ANSI 3" x 1.5" x 6", 3" x 1.5" x 8"
GC	ANSI 3" x 2" x 6"
G10	ANSI 3" x 2" x 6"
G50	ANSI 3" x 1.5" x 8", 3" x 1.5" x 10"
G60	ANSI 3" x 2" x 8", 3" x 2" x 10"
G20	ANSI 3" x 1.5" x 13"
G30	ANSI 3" x 2" x 13"
G70	ANSI 4" x 3" x 8", 4" x 3" x 10"
G40	ANSI 4" x 3" x 10", 4" x 3" x 13"
G22	ANSI 2" x 2"
G33	ANSI 3" x 3"
G44	ANSI 4" x 4"

##### Materials

A	Basic version
D	Carbon-graphite filled PTFE (bearings)
G	Wetted parts AISI 316
GI	All parts stainless steel, wetted parts AISI 316
K	Bronze (bearings)
S	SiC bearings + PTFE neck rings
X	Special version

##### Code for rubber parts

E	EPDM
F	FXM
K	FFKM
V	FKM

##### Shaft seal

H	Balanced cartridge seal with O-ring
K	Metal bellows cartridge seal
O	Double seal, back-to-back
P	Double seal, tandem
X	Special version
B	Carbon, synthetic resin-impregnated
H	Cemented tungsten carbide, embedded (hybrid)
Q	Silicon carbide
U	Cemented tungsten carbide
X	Other ceramics
E	EPDM
F	FXM
K	FFKM
V	FKM

<sup>1)</sup> If a pump incorporates more than two pump versions, the code for the pump version is X. X also indicates special pump versions not listed above.

<sup>2)</sup> The pipe connection code designates the pump as a **CR horizontal end-suction pump**.

## 7. MLE technical data

Grundfos MLE motors are equipped with NEMA standard C-face flanges.

Grundfos MLE motors are recognized under the Component Recognition Program of Underwriters Laboratories Inc. for the United States and Canada.

MLE motors are equipped with a reinforced bearing system with locked bearings at the drive end, either a deep-groove ball bearing or an angular-contact bearing depending on the motor model.

This ensures an even uptake of the load in order to maximize the lifetime of the bearings, which are guaranteed for a minimum of 18,000 hours service life. At the non-drive end, the motors are fitted with bearings with axial clearance in order to meet production tolerances while allowing for thermal expansion during motor operation. This ensures trouble-free operation and long life.

### MLE permanent-magnet motors 1/2 - 2 HP

#### (2-pole) 1/60/200-240

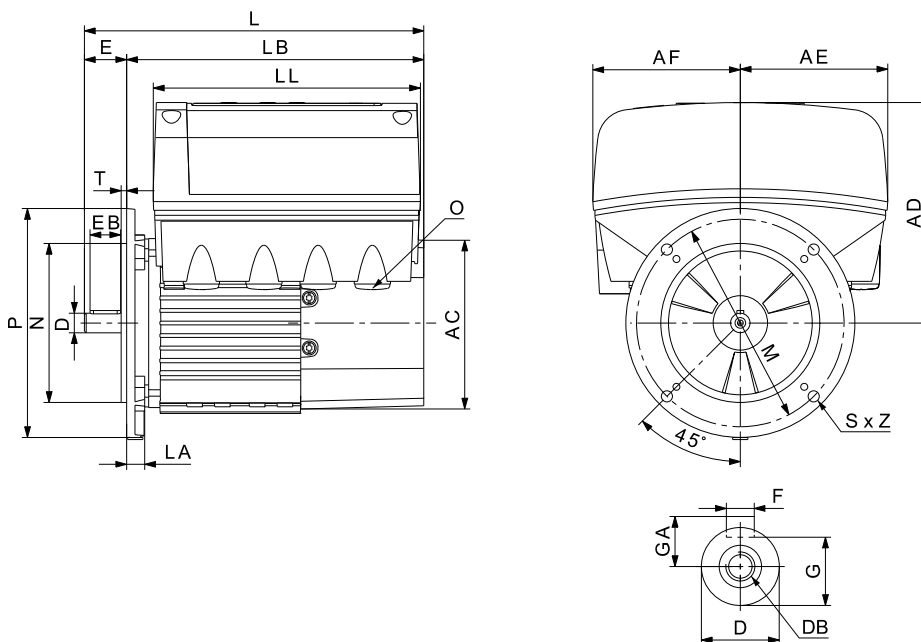

TM05 6786 5012

#### 2-pole dimensional data

Power [HP]	NEMA frame	Stator housing [inches (mm)]							Shaft end [inches (mm)]	
		AC	AD	AF	L	LB	LL	D	E	
1/2	56C									
3/4										
1		4.80 (122)	6.22 (158)	4.17 (106)	10.55 (268)	8.46 (215)	7.56 (192)	0.63 (15.9)	2.06 (52.3)	
1 1/2										
2		4.80 (122)	6.22 (158)	4.17 (106)	11.34 (288)	9.25 (235)	7.56 (192)	0.63 (15.9)	2.06 (52.3)	

Power [HP]	NEMA Frame	Flange [inches (mm)]						Cable entries [mm]	
		LA	M	N	P	S	T	O	
1/2	56C								
3/4									
1		0.63 (16)	5.87 (149.2)	4.50 (114.3)	6.50 (165)	3/8"	0.16 (4)	1/2" NPT (4)	
1 1/2									
2		1.42 (36)	5.87 (149.2)	4.50 (114.3)	6.50 (165)	3/8"	0.16 (4)	1/2" NPT (4)	

## MLE permanent-magnet motors 1-15 HP

(2-pole) 3/60/440-480

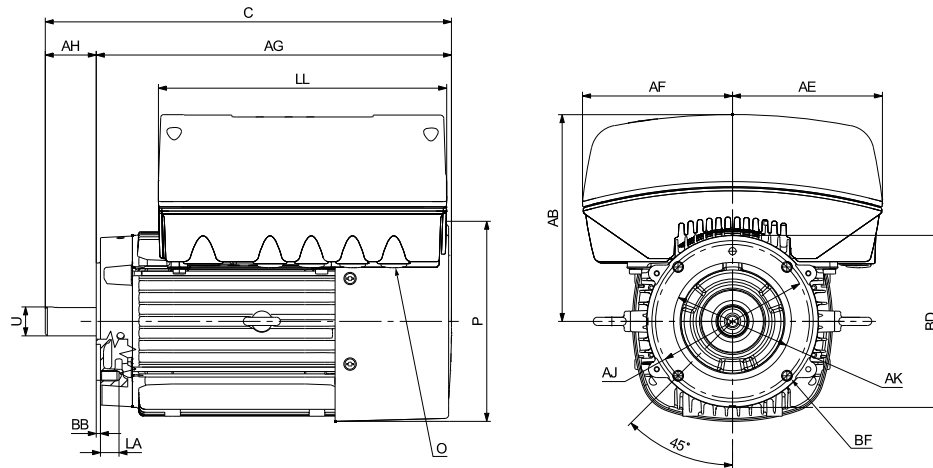

TM06 6518 3316

## Dimensional data

Power [HP]	NEMA frame	Stator housing [inches (mm)]							Shaft end [inches (mm)]	
		P	AB	AE	AF	C	AG	LL	U	AH
1	56C	4.80 (122)	6.22 (158)	5.28 (134)	5.28 (134)	12.13 (308)	10.04 (255)	9.13 (232)	0.63 (15.9)	2.06 (52.3)
1 1/2		4.80 (122)	6.22 (158)	5.28 (134)	5.28 (134)	12.91 (328)	10.83 (275)	9.13 (232)	0.63 (15.9)	2.06 (52.3)
20		4.80 (122)	6.22 (158)	5.28 (134)	5.28 (134)	12.39 (314.75)	10.51 (267)	9.13 (232)	0.63 (16.075)	1.88 (47.75)
30	182TC	4.80 (122)	6.22 (158)	5.28 (134)	5.28 (134)	13.46 (342)	10.83 (275)	9.13 (232)	1.13 (28.6)	2.62 (66.6)
5		7.53 (191.3)	7.91 (201)	5.73 (145.5)	5.73 (145.5)	15.89 (403.6)	13.15 (334)	11.02 (280)	1.13 (28.6)	2.74 (69.6)
7 1/2	213TC	7.53 (191.3)	7.91 (201)	5.73 (145.5)	5.73 (145.5)	17.75 (450.9)	14.37 (365)	11.02 (280)	1.37 (34.9)	3.38 (85.9)
10		10.04 (254.9)	9.33 (237)	6.81 (173)	6.81 (173)	18.70 (474.9)	15.31 (389)	12.48 (317)	1.37 (34.9)	3.38 (85.9)
15	254TC	10.04 (254.9)	9.33 (237)	6.81 (173)	6.81 (173)	19.74 (501.3)	15.98 (406)	12.48 (317)	1.63 (41.3)	3.75 (95.3)

Power [HP]	NEMA frame	Flange [inches (mm)]						Cable entries [mm]
		LA	AJ	AK	BD	BF	BB	O
10	56C	0.63 (16)	5.87 (149.2)	4.50 (114.3)	6.50 (165)	3/8"	0.16 (4)	1/2" NPT (4)
1 1/2		1.42 (36)	5.87 (149.2)	4.50 (114.3)	6.50 (165)	3/8"	0.16 (4)	1/2" NPT (4)
20		0.51 (12.9)	5.87 (149.2)	4.50 (114.3)	6.53 (165.8)	3/8"	0.16 (4)	1/2" NPT (5)
30	182TC	0.75 (19)	7.25 (184.15)	8.50 (215.9)	8.50 (215.9)	1/2" - 13	0.25 (6.35)	1/2" NPT (5)
5		0.79 (20)	7.25 (184.15)	8.50 (215.9)	8.68 (220.5)	1/2" - 13	0.25 (6.35)	3/4" NPT (1) & 1/2" NPT (5)
7 1/2	213TC	0.79 (20)	7.25 (184.15)	8.50 (215.9)	8.68 (220.5)	1/2" - 13	0.25 (6.35)	3/4" NPT (1) & 1/2" NPT (5)
10		0.79 (20)	7.25 (184.15)	8.50 (215.9)	8.68 (220.5)	1/2" - 13	0.25 (6.35)	3/4" NPT (1) & 1/2" NPT (5)
15	254TC	0.79 (20)	7.25 (184.15)	8.50 (215.9)	8.68 (220.5)	1/2" - 13	0.25 (6.35)	3/4" NPT (1) & 1/2" NPT (5)

# MLE permanent-magnet motors 1 1/2 - 7 1/2 HP

## 1 1/2 - 7 1/2 HP (2-pole) 3/60/200-240

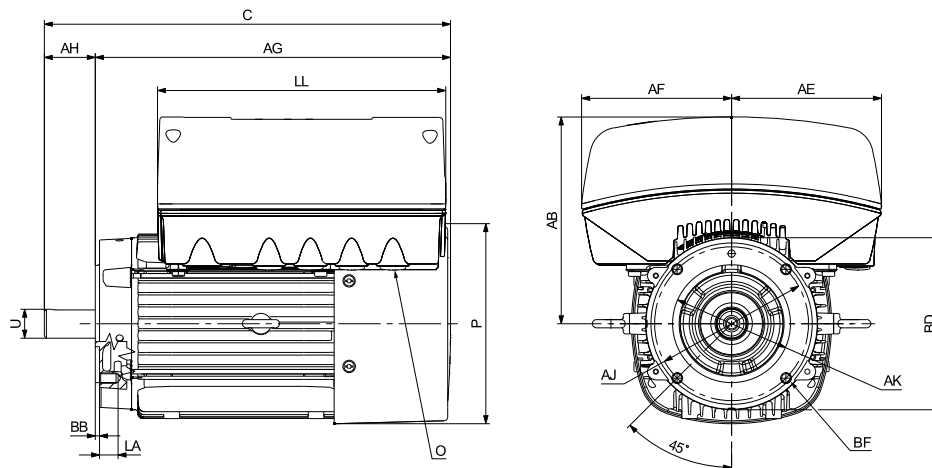

TM06 6518 3316

### Dimensional data

Power [HP]	NEMA frame	Stator housing [inches (mm)]							Shaft end [inches (mm)]	
		P	AB	AE	AF	C	AG	LL	U	AH
1 1/2	56C	4.80 (122)	6.22 (158)	5.28 (134)	5.28 (134)	12.13 (308)	10.04 (255)	9.13 (232)	0.63 (15.9)	2.06 (52.3)
2		4.80 (122)	6.22 (158)	5.28 (134)	5.28 (134)	12.91 (328)	10.83 (275)	9.13 (232)	0.63 (15.9)	2.06 (52.3)
3	182TC	7.53 (191.3)	7.917 (201)	5.73 (145.5)	5.73 (145.5)	15.89 (403.6)	13.15 (334)	11.02 (280)	1.13 (28.6)	2.74 (69.6)
5		7.53 (191.3)	7.91 (201)	5.73 (145.5)	5.73 (145.5)	15.89 (403.6)	13.15 (334)	11.02 (280)	1.13 (28.6)	2.74 (69.6)
7 1/2	213TC	10.04 (254.9)	9.33 (237)	6.81 (173)	6.81 (173)	18.70 (474.9)	15.31 (389)	12.48 (317)	1.37 (34.9)	3.38 (85.9)

Power [HP]	NEMA frame	Flange [inches (mm)]						Cable entries
		LA	AJ	AK	BD	BF	BB	O
1 1/2	56C	0.63 (16)	5.87 (149.2)	4.50 (114.3)	6.50 (165)	3/8"	0.16 (4)	1/2" NPT (4)
2		1.42 (36)	5.87 (149.2)	4.50 (114.3)	6.50 (165)	3/8"	0.16 (4)	1/2" NPT (4)
3	182TC	0.75 (19)	7.25 (184.15)	8.50 (215.9)	8.50 (215.9)	1/2"-13	0.25 (6.35)	1/2" NPT (5)
5		0.75 (19)	7.25 (184.15)	8.50 (215.9)	8.50 (215.9)	1/2"-13	0.25 (6.35)	1/2" NPT (5)
7 1/2	213TC	0.79 (20)	7.25 (184.15)	8.50 (215.9)	8.68 (220.5)	1/2"-13	0.25 (6.35)	3/4" NPT (1) & 1/2" NPT (5)

## MLE asynchronous motors 20-30 HP

(2-pole) 3/60/460-480

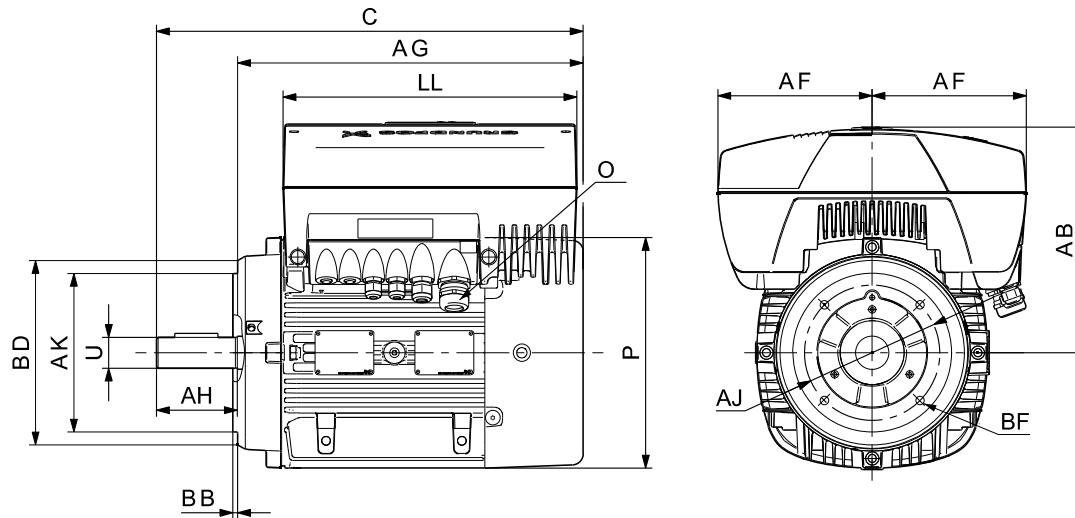

TM04 5498 3309

## Dimensional data

Power [HP]	Nema frame	Stator housing [inches (mm)]							Shaft end [inches]	
		P	AB	AF	AF	C	AG	LL	U	AH
20	256TC	13.39 (340)	12.13 (308)	8.27 (210)	8.27 (210)	22.56 (573)	18.78 (477)	15.75 (400)	1.62 (41)	3.75 (95)
25	284TC	13.39 (340)	12.13 (308)	8.27 (210)	8.27 (210)	24.53 (623)	22.72 (577)	15.75 (400)	1.62 (41)	3.75 (95)
30	286TC	13.39 (340)	12.13 (308)	8.27 (210)	8.27 (210)	24.53 (623)	22.72 (577)	15.75 (400)	1.62 (41)	3.75 (95)

Power [HP]	Nema frame	Flange [inches (mm)]					Cable entries [mm]
		AJ	AK	BD	BF	BB	O
20	256TC	7.25 (184)	8.50 (216)	9.88 (251)	1/2"	0.26 (7)	1 x M40 + 1 x M20 + 2 x M16 + 2 x knock out M16
25	284TC	9.00 (229)	10.50 (267)	10.75 (273)	1/2"	0.32 (8)	1 x M40 + 1 x M20 + 2 x M16 + 2 x knock out M16
30	286TC	9.00 (229)	10.50 (267)	10.75 (273)	1/2"	0.32 (8)	1 x M40 + 1 x M20 + 2 x M16 + 2 x knock out M16

## MLE motors for CRE-H and CRNE-H

(C-Face mounting with foot)

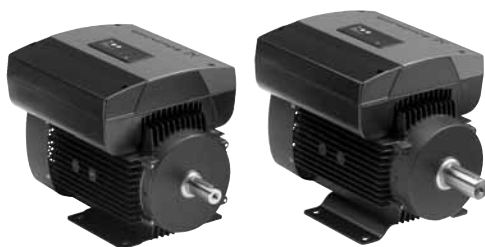

GR9035

### Dimensional sketch

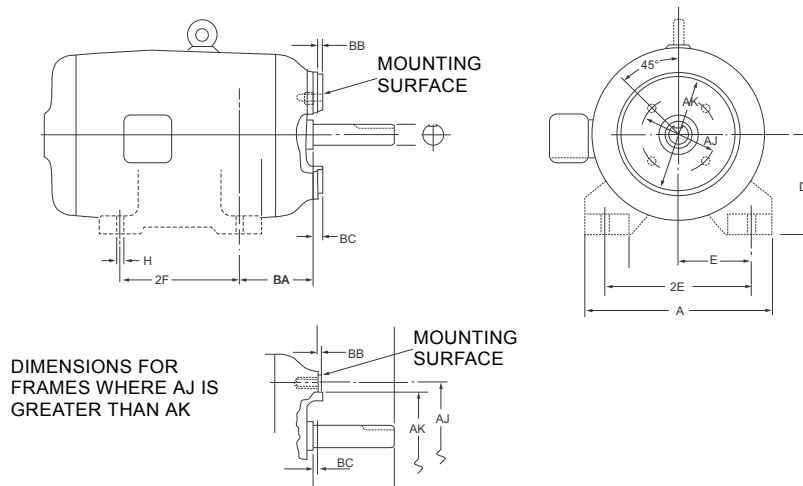

TM05 3012 0812

### Dimensional data

Power [HP]	PH	NEMA frame size	Foot dimensions [inches]						
			A	D	E	2E	2F	BA + BC	H
<b>One-phase 2-pole MLE motor with foot</b>									
1/2	1	56C	6.00	3.50	2.44	4.88	3.00	2.56	0.34
3/4	1	56C	6.00	3.50	2.44	4.88	3.00	2.56	0.34
1	1	56C	6.00	3.50	2.44	4.88	3.00	2.56	0.34
1 1/2	1	56C	6.00	3.50	2.44	4.88	3.00	2.56	0.34
2	1	56C	6.00	3.50	2.44	4.88	3.00	2.56	0.34
<b>Three-phase 2-pole MLE motor with foot</b>									
1	3	56C	6.00	3.50	2.44	4.88	3.00	2.56	0.34
1 1/2	3	56C	6.00	3.50	2.44	4.88	3.00	2.56	0.34
2	3	56C	6.00	3.50	2.44	4.88	3.00	2.56	0.34
3	3	182TC	8.90	4.50	3.75	7.50	4.50	2.87	0.41
5	3	184TC	8.90	4.50	3.75	7.50	5.50	2.87	0.41
7 1/2	3	215TC	9.96	5.25	4.25	8.50	7.00	3.75	0.41
10	3	215TC	9.60	5.25	4.25	8.50	7.00	3.75	0.41
15	3	254TC	11.30	6.25	5.00	10.00	8.25	4.50	0.53
20	3	256TC	11.30	6.25	5.00	10.00	10.00	4.50	0.53
25	3	284TSC	12.30	7.00	5.50	11.00	9.50	5.00	0.53
30	3	286TSC	12.30	7.00	5.50	11.00	11.00	5.00	0.53

## 8. Control of E-pumps

### Examples of E-pump applications

CRE-H, CRNE-H pumps are the ideal choice for a number of applications characterized by a demand for a variable flow rate at constant pressure. The pumps are suited for water supply systems and pressure boosting as well as for industrial applications.

Depending on the application, the pumps offer energy savings, increased comfort and improved processing.

#### E-pumps in the service of industry

The industry uses a large number of pumps in many different applications. Demands on pumps in terms of pump performance and mode of operation make speed control a must in many applications.

Some of the applications in which E-pumps are often used are listed below.

#### Constant pressure

- Water supply
- washing and cleaning systems
- distribution from waterworks
- humidifying systems
- water treatment systems
- process boosting systems, etc.

**Example:** Within industrial water supply, E-pumps with integrated pressure sensor are used to ensure a constant pressure in the pipe system. From the sensor, the E-pump receives inputs about changes of pressure as a result of changes in the consumption. The E-pump responds to the input by adjusting the speed until the pressure is equalized. The constant pressure is stabilized once more on the basis of a preset setpoint.

#### Constant temperature

- Air-conditioning systems at industrial plants
- industrial cooling systems
- industrial freezing systems
- casting and molding tools, etc.

**Example:** In industrial freezing systems, E-pumps with temperature sensor increase comfort and lower operating costs compared with pumps without a temperature sensor.

An E-pump continuously adapts its performance to the changing demands reflected in the differences in temperature of the liquid circulating in the freezing system. Thus, the lower the demand for cooling, the smaller the quantity of liquid circulated in the system and vice versa.

#### Constant level

- Boiler feed systems
- condensate systems
- sprinkler irrigation systems
- chemical industry, etc.

**Example:** In a steam boiler, it is important to be able to monitor and control pump operation to maintain a constant level of water in the boiler.

By using an E-pump with level sensor in the boiler, it is possible to maintain a constant water level.

A constant water level ensures optimum and cost-efficient operation as a result of a stable steam production.

#### Dosing applications

- Chemical industry, i.e. control of pH values
- petrochemical industry
- paint industry
- degreasing systems
- bleaching systems, etc.

**Example:** In the petrochemical industry, E-pumps with pressure sensor are used as dosing pumps. The E-pumps help to ensure that the correct mixture ratio is achieved when more liquids are combined.

E-pumps functioning as dosing pumps improve processing and offer energy savings.

#### E-pumps in commercial building services

Commercial building services use E-pumps to maintain a constant pressure or a constant temperature based on a variable flow rate.

#### Constant pressure

Water supply in high-rise buildings, such as office buildings and hotels.

**Example:** E-pumps with pressure sensor are used for water supply in high-rise buildings to ensure a constant pressure even at the highest draw-off point. As the consumption pattern and thus the pressure changes during the day, the E-pump continuously adapts its performance until the pressure is equalized.

#### Constant temperature

- Air-conditioning systems in hotels, schools, etc.
- building cooling systems, etc.

**Example:** E-pumps are an excellent choice for buildings where a constant temperature is essential. E-pumps keep the temperature constant in air-conditioned, high-rise glass buildings, irrespective of the seasonal fluctuations of the outdoor temperature and various heat impacts inside the building.

## Control options

It is possible to communicate with CRE, CRNE, CRNE pumps via the following:

- control panel on the pump
- Grundfos R100 remote control
- Grundfos GO Remote
- central management system.

The purpose of controlling an E-pump is to monitor and control the pressure, temperature, flow rate and liquid level of the system.

### Control panel on pump

The control panel on the E-pump terminal box makes it possible to change the setpoint settings manually.

#### MLE permanent-magnet motors

1/2 to 2 HP (1 x 200-240 V)

1 to 15 HP (3 x 440-480 V)

1 1/2 to 7 1/2 HP (3 x 200-240 V)

The operating condition of the pump is indicated by the Grundfos Eye on the control panel. See fig. 18.

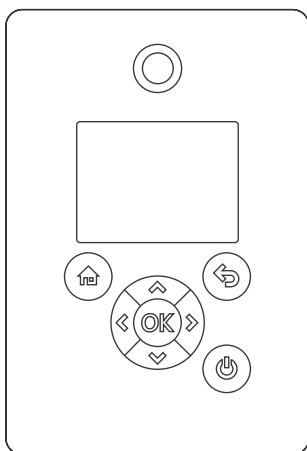

Fig. 18 Control panel on CRE pump

TM06 9616 2517

### MLE asynchronous motors 20 to 30 HP (3 x 460-480 V)

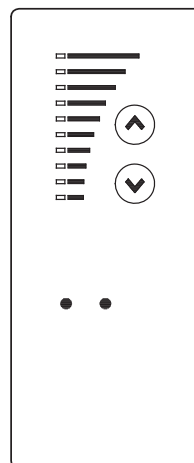

Fig. 19 Control panel on CRE pump

TM02 8513 0304

### Grundfos GO Remote

The pump is designed for wireless radio or infrared communication with Grundfos GO Remote.

Grundfos GO Remote enables setting of functions and gives access to status overviews, technical product information and actual operating parameters.

Grundfos GO Remote offers three different mobile interfaces (MI).

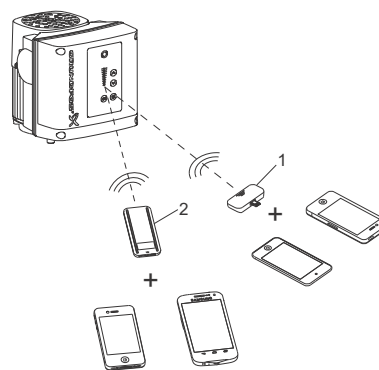

Fig. 20 Grundfos GO Remote communicating with the pump via radio or infrared connection (IR)

TM06 6256 0916

Pos.	Description
1	Grundfos MI 204: Add-on module enabling radio or infrared communication. You can use MI 204 in conjunction with an Apple iPhone or iPod with Lightning connector, e.g., fifth generation or later iPhone or iPod. MI 204 is also available together with an Apple iPod touch and a cover.
2	Grundfos MI 301: Separate module enabling radio or infrared communication. You can use the module in conjunction with an Android or iOS-based smart device with Bluetooth connection.

## Central management system

Communication with the E-pump is possible even if the operator is not present near the E-pump. Communication is enabled by connecting the E-pump to a central management system. This allows the operator to monitor the pump and to change control modes and setpoint settings.

Control management system

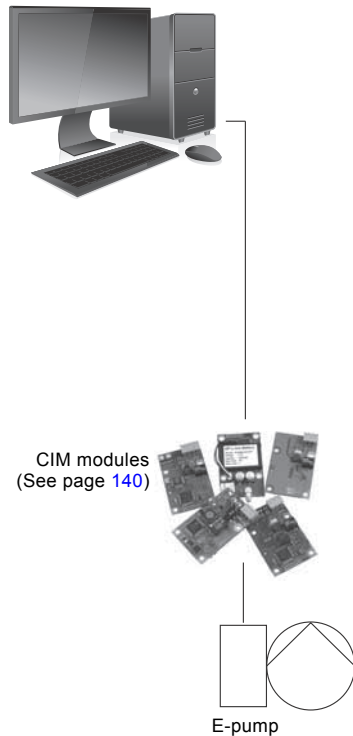

Fig. 21 Structure of a central management system

TM04 5022 1111

## Control modes for E-pumps

Grundfos CRE-H, CRNE-H pumps are available in two variants:

- CRE-H, CRNE-H with integrated pressure sensor
- CRE-H, CRNE-H without sensor.

### CRE-H, CRNE-H with integrated pressure sensor

Use CRE-H, CRNE-H pumps with integrated pressure sensor in applications where you want to control the pressure after the pump, irrespective of the flow rate. For further information, see section [Examples of E-pump applications](#) on page 22.

Signals of pressure changes in the pipe system are transmitted continuously from the sensor to the pump. The pump responds to the signals by adjusting its performance up or down to compensate for the pressure difference between the actual and the desired pressure. As this adjustment is a continuous process, a constant pressure is maintained in the pipe system.



Fig. 22 CRE-H pumps

TM04 4177 0909

A CRE-H, CRNE-H pump with integrated pressure sensor facilitates installation and commissioning. CRE-H, CRNE-H pumps with integrated pressure sensor can be set to either of these control modes:

- constant pressure (factory setting)
- constant curve.

In constant-pressure mode, the pump maintains a preset pressure after the pump, irrespective of the flow rate. See fig. 23.

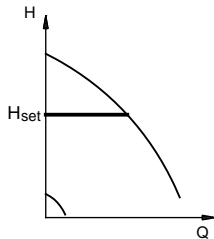

Fig. 23 Constant-pressure mode

In constant-curve mode, the pump is not controlled. It can be set to pump according to a preset pump characteristic curve within the range from minimum curve to maximum curve. See fig. 24.

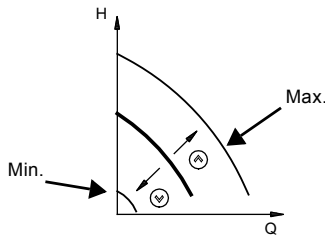

Fig. 24 Constant-curve mode

TM00 9322 4796

TM00 9323 1204

### CRE-H, CRNE-H without sensor

CRE-H, CRNE-H pumps without sensor are suitable in these situations:

- Uncontrolled operation is required.
- Retrofit the sensor in order to control the flow rate, temperature, differential temperature, liquid level, pH value, etc. at some arbitrary point in the system.

### MLE permanent-magnet motors

1/2 to 2 HP (1 x 200-240 V)

1 to 15 HP (3 x 440-480 V)

1 1/2 to 7 1/2 HP (3 x 200-240 V)

These CRE-H, CRNE-H pumps without sensor can be set to either of these control modes:

- Constant pressure
- constant differential pressure
- constant temperature
- constant differential temperature
- constant flow rate
- constant level
- constant curve
- constant other value.

### MLE asynchronous motors

20 to 30 HP (3 x 460-480 V)

These CRE-H, CRNE-H pumps without sensor can be set to either of these control modes:

- Controlled operation
- uncontrolled operation (factory setting).

In controlled-operation mode, the pump adjusts its performance to the desired setpoint. See fig. 25.

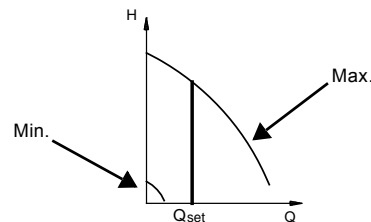

Fig. 25 Constant-flow mode

In uncontrolled-operation mode, the pump operates according to a preset pump characteristic curve. See fig. 24.

TM02 7264 2803

## 9. Advanced use of MLE motors

### Introduction

Grundfos MLE motors have many features for the advanced user.

Grundfos three-phase MLE motors have features such as bearing monitoring, standstill heating, stop function, signal relays, analog sensors and limit exceeded. These features give a unique opportunity to customize the E-pumps.

The PC Tool E-products gives access to most of the settings available in the products, as well as the possibility of logging and viewing data.

All of these features are described below.

### Bearing monitoring

Bearing monitoring is a built-in function indicating the time to relubricate or replace the bearings of the MLE motor. The relubrication feature is only available for three-phase pumps of 15-30 HP.

#### Purpose and benefits

The purpose of this function is to give an indication to the user when it is time to relubricate or replace the motor bearings. This is important information for maintenance planning.

Bearing monitoring provides these benefits:

- The bearing can be relubricated at the right time according to the manufacturer's recommendations.
- Maximum life of the motor bearings is obtained.
- Maintenance intervals are determined by the pump itself.
- No worn-down or damaged bearings, and consequently no costly down-time, due to overseen maintenance.

#### Description

When the bearing monitoring function determines that it is time to relubricate the bearings, the user will receive a warning via R100, PC Tool E-products, bus or relay.

When the bearings have been relubricated, a certain number of times, the warning function will inform the user to replace the bearings.

The number of relubrications before bearing replacement is set by Grundfos.

### Technical description

The bearing monitoring function is available on two levels for calculating the relubrication interval, basic and advanced:

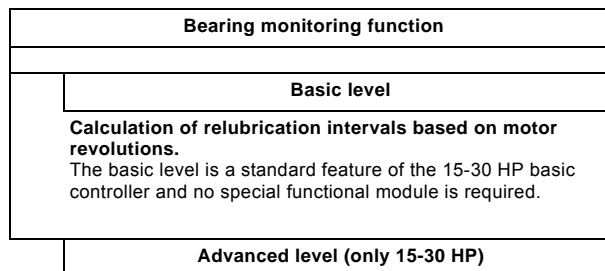

**Calculation of relubrication intervals based on motor revolutions and bearing temperature.**

**Note:** The advanced-level function requires the following:

- The extended functional module is fitted in the MLE motor as standard.
- Temperature sensors are fitted at the drive end and at the non-drive end of the motor.

### Standstill heating

Standstill heating is a feature ensuring that even during standstill periods the motor windings have a certain minimum temperature.

#### Purpose and benefits

The purpose of this function is to make the MLE motor more suitable for outdoor installation. During standstill periods, there is a need to keep the motor temperature higher than the ambient temperature to avoid condensation in and on the motor.

Traditionally this issue has been solved by using an anti-condensation heater on the stator coil heads. Now Grundfos provides this feature by means of a special function within the MLE motor and terminal box.

The MLE motor has standstill heating included. An external heater on the stator coil is not necessary.

#### Applications

This function is especially suitable in outdoor applications and at installation sites with fluctuating temperatures.

#### Description

The working principle is that AC voltage is applied to the motor windings. The applied AC voltage will ensure that sufficient heat is generated to avoid condensation in the motor. The terminal box is kept warm and dry by the heat generated via the power supply. However, it is a condition that the terminal box is not exposed to open air. It must be provided with a suitable cover to protect it from rain.

## Outdoor installation

According to UL 778-C22.2 No 108-14 pumps that are intended for outdoor use shall be marked enclosure type 3 and the product shall be tested with rated surface temperature down to -31 °F (-35 °C). The MLE enclosure is approved for type 3 or 4 and rated surface temperature down to 32 °F (0 °C), thus only for indoor use in UL 778-C22.2 No 108-14 pump applications. See the Installation and Operating Instructions for additional details.

## Stop function

The stop function ensures that the pump is stopped at low or no flow. The function is also called low-flow stop function.

### Purpose and benefits

The purpose of the stop function is to stop the pump when low flow is detected.

The stop function provides these benefits:

- The energy consumption is optimized and the system efficiency is improved.
- Unnecessary heating of the pumped liquid which damages pumps.
- Wear of the shaft seals is reduced.
- Noise from operation is reduced.

### Applications

The stop function is used in systems with periodically low or no consumption thus preventing the pump from running against closed valve.

### Operating conditions for the stop function

A pressure sensor, a check valve, and a diaphragm tank are required for the stop function to operate properly.

**Note:** The check valve must always be installed before the pressure sensor. See fig. 26 and fig. 27.

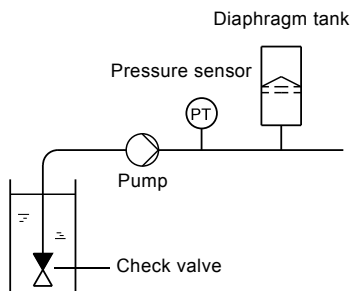

**Fig. 26** Position of the check valve and pressure sensor in system with suction lift operation

TM03 8582 1907

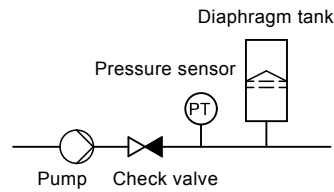

**Fig. 27** Position of the check valve and pressure sensor in system with positive inlet pressure

TM03 8583 1907

When low flow is detected, the pump is in on/off operation. If there is flow, the pump will continue operating according to the setpoint. See fig. 28.

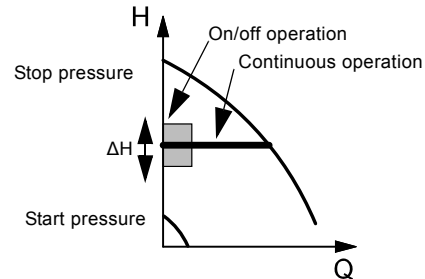

**Fig. 28** Constant pressure with stop function. Difference between start and stop pressures ( $\Delta H$ )

TM03 8477 1607

### Diaphragm tank

The stop function requires a diaphragm tank of a certain minimum size. The tank must be installed near the outlet of the pump, and the precharge air pressure must be 0.7 x setpoint.

Recommended diaphragm tank size:

Rated flow rate of pump [gpm (m <sup>3</sup> h)]	CRE-H pump	Typical diaphragm tank size [gal (liter)]
0-26 (0 - 5.9)	1s, 1, 3	2 (7.6)
27-105 (6.1 - 23.8)	5, 10, 15	4.4 (16.7)
106-176 (24.2 - 40)	20, 32	14 (53.0)
177-308 (40.2 - 70.0)	45	34 (128.7)
309-440 (70.2 - 99.9)	64, 90	62 (234.7)
441-750 (100-170)	120, 150	86 (325.5)

If a diaphragm tank of the above size is installed in the system, no additional adjustment should be necessary. If the tank installed is too small, the pump will start and stop often. Tank size will influence at which flow rate the system will go into start/stop operation.

## Description

The low-flow stop function can operate in two different ways:

- by means of an integrated "low-flow detection function"
- by means of an external flow switch connected to the digital input.

### Low-flow detection function

The low-flow detection function will check the flow rate regularly by reducing the speed for a short time. A small change in pressure or no change in pressure means that the flow rate is low.

### Low-flow detection with flow switch

When a flow switch detects low flow, the digital input will be activated.

Contact Grundfos for further information.

### Dry-running protection

This function protects the pump against dry running. When lack of inlet pressure or water shortage is detected, the pump will be stopped before being damaged.

Lack of inlet pressure or water shortage can be detected with a switch connected to a digital input configured to dry-running protection.

The use of a digital input requires an accessory, such as:

- a Grundfos Liqtec® dry-running switch (for more information on LiqTec, see section [15. Accessories](#))
- a pressure switch installed on the inlet side of the pump
- a float switch installed on the inlet side of the pump.

The pump cannot restart as long as the digital input is activated.

## Temperature sensors 1 and 2

One or two Pt100 temperatures sensors may be connected to the input terminals 17, 18, 19, and 20.

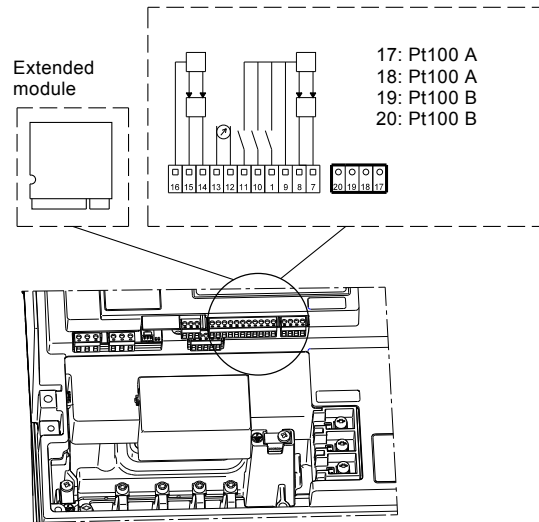

Fig. 29 Temperature sensor connections in the extended functional module

### Purpose and benefits

The temperature sensor inputs 1 and 2 provide these benefits:

- The temperature sensor inputs can be used as input to the "limit exceeded" functions 1 and 2.
- In combination with the bearing monitoring function, the temperature sensors provide optimum monitoring of the motor bearings.
- A bearing warning or a bearing alarm can be indicated as the motor bearing temperature is measured.
- Status readings of the measured temperatures are available via R100, PC Tool E-products and bus.
- The function has a built-in signal fault detection if the temperature sensors fail or a conductor is broken.

### Applications

The temperature inputs can be used in all applications where temperatures in the system or in the motor need to be monitored.

**Note:** The temperature sensor inputs are available on all MLE motors.

TM03 9191 3507

### Description

The temperature sensor inputs enable several functions.

- The temperature sensor inputs 1 and 2 can be used as input to the "limit exceeded" functions 1 and 2. If a limit is exceeded, this will be indicated. The indication will be in the form of outputs (relay) or alarms/warnings set/defined in the "limit exceeded" functions 1 and 2.
- The temperature sensor inputs 1 and 2 can be set to measure bearing temperature. The measured values of temperature sensor 1 and 2 are used in the calculation of relubrication intervals. Additionally, the measured value can activate the indication of a bearing warning or a bearing alarm. In case of high bearing temperature, a warning or an alarm can be logged and force the pump to stop.

### Signal relays

Signal relays are used to give an output indication of the current operational status of the MLE. The signal relay is a potential free contact (also called a dry contact). The output signals are typically transmitted to external control systems.

#### Purpose and benefits

The signal relays offer these features:

- The signal relays can be remotely (via bus) or internally controlled.
- The signal relays can be set to indicate several types of operational status.
- A relay delay can be defined to avoid activating the relay in case of periodic failures.

#### Applications

Signal relays can be used in all applications involving a need to read out the operational status to e.g. a control room or to a superior control system.

### Description

The signal relays can be set with these three parameters:

- relay control
- relay setup
- relay delay.

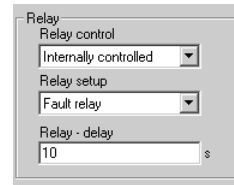

Fig. 30 Signal relay parameters for 1/2 - 10 HP pumps

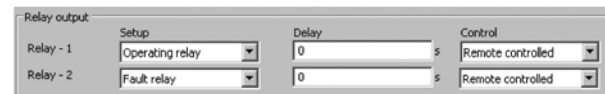

Fig. 31 Signal relay parameters for 15 - 30 HP pumps

### Relay control

The relay time is 0 seconds and the signal relay is internally controlled.

The advanced relay control can only be set via the PC Tool E-products.

Relay control has these two setting options:

- **Internally controlled**  
The relay is internally controlled by the variable frequency drive software according to the setup of the relay [Ready, Fault, Operation].
- **Remotely controlled**  
The relay is controlled via commands from the GENibus.

## Analog sensor inputs 1 and 2

The analog sensor inputs 1 and 2 are standardized inputs for measuring all types of analog parameters.

Sensor input 1 is the only sensor input set for closed-loop operation. The input will be used as the sensor feedback input.

Sensor input 2 is referred to as the secondary sensor.

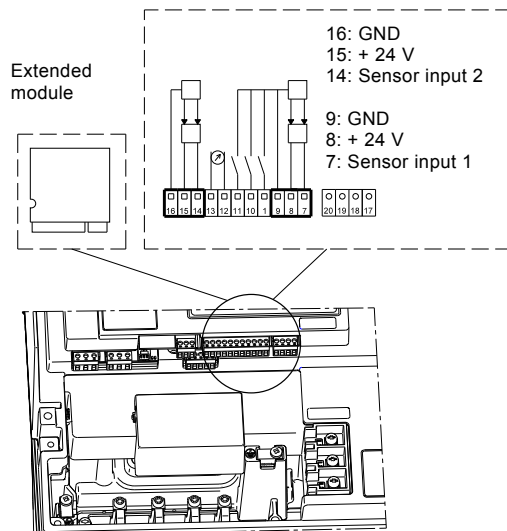

Fig. 32 Sensor inputs 1 and 2 connections

### Purpose and benefits

The analog sensor inputs 1 and 2 provide these benefits:

- Sensor input 1 can be feedback input for the built-in PI controller.
- It is possible to monitor secondary parameters in the process, e.g. flow rate or liquid temperature.
- The secondary sensor can be set as a redundant sensor.
- The sensors can give input to the "limit exceeded" functions 1 and 2.
- Status readings of the inputs are available via R100 and PC Tool E-products.

### Applications

Analog sensor inputs 1 and 2 can be used in applications with a need for monitoring essential parameters.

### Description

The analog sensors 1 and 2 enable several functions.

- When the secondary sensor is set as an input to the "limit exceeded" functions 1 and 2, defined outputs or warnings or alarms can be given when system parameters are outside defined system limits.
- Connecting a flow sensor.  
When sensor input 2 is set with a flow sensor, the measured value can be used as input to the proportional-pressure function. The flow rate displayed in R100 will be the measured flow rate instead of the estimated flow rate.

The flow rate measurement can also be used in the low-flow stop function to detect low flow instead of estimating the flow rate by lowering the speed of the pump.

- Sensor reading via R100 and PC Tool E-products.  
When sensors are set, the user can get a status reading via R100 and PC Tool E-products.

### Analog output

#### Analog output

The analog output (0-10 mA) can be set via the PC Tool to one of these indications:

- feedback value
- speed
- frequency
- motor current
- external setpoint input
- limit exceeded.

The analog output is default set to not active.

#### Feedback value

The output signal is a function of the actual feedback sensor.

#### Speed

The output signal is a function of the actual pump speed.

#### Frequency

The output signal is a function of the actual frequency.

#### Motor current

The output signal is a function of the actual motor current.

#### External setpoint input

The output signal is a function of the external setpoint input.

#### Limit exceeded

The output signal indicates whether the limit is exceeded:

- Minimum output = limit is not exceeded.
- Maximum output = limit is exceeded.

TM03 9214 3607

### Limit exceeded 1 and 2

Limit exceeded is a monitoring function monitoring one or two values/inputs. The function enables different inputs to activate various outputs and alarms/warnings when the signal input has exceeded pre-determined limits.

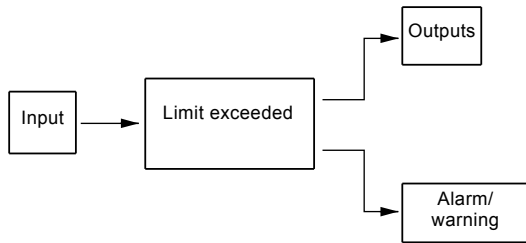

Fig. 33 Example of a "limit exceeded" sequence

#### Purpose and benefits

The purpose of this function is to monitor parameters which are central for the application. This will enable the controller to react to possible, abnormal operating conditions. This makes the E-pump a more important and integrated part of a system, and it can thus replace other existing monitoring units.

The liquid temperature can be monitored, and thus the E-pump can ensure that the system temperature does not exceed a maximum permissible level.

The minimum inlet pressure can be monitored, and thus the E-pump can prevent damage caused by a cavitation or dry run.

#### Applications

The limit exceeded function is typically used for monitoring secondary parameters in the systems.

#### Description

The figures below show two examples of setpoint monitoring by means of the limit exceeded function.

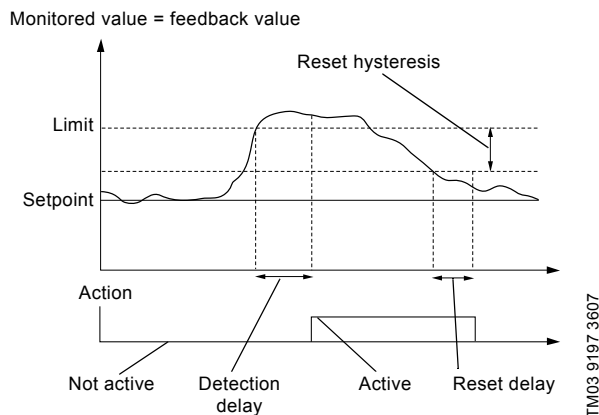

Fig. 34 Limit exceeded sequence with the limit type "max. limit", for example monitoring of bearing temperature

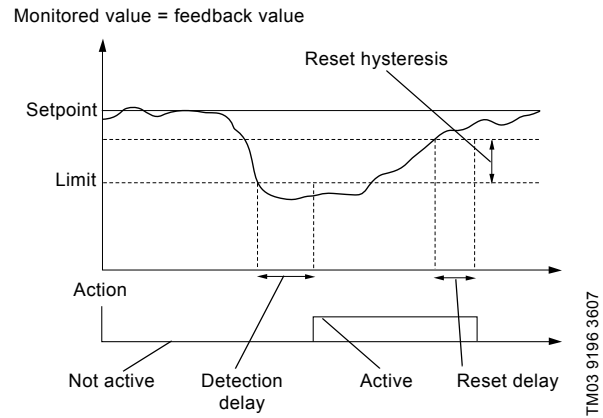

Fig. 35 Limit exceeded sequence with the limit type "min. limit" When the limit is exceeded, the signal input crosses the limit as an increasing or decreasing value, and the function can be set to cover both situations.

#### Pump operating at power limit

When a pump operates at the power limit, the MLE motor will deliver an output corresponding to the maximum load stated on the nameplate. The maximum load will never be exceeded, see fig. 36.

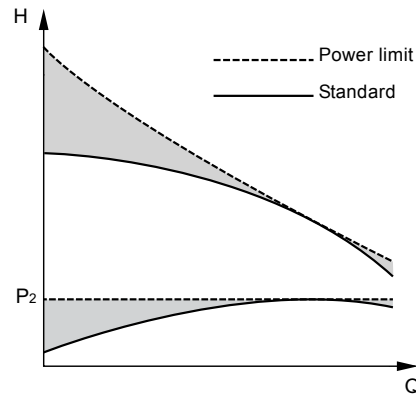

Fig. 36 Curves of a standard E-pump and a pump operating at power limit

### Purpose and benefits

When using a standard pump at a low flow rate, the power consumption will drop and the motor will have excess power available.

By setting the CRE pump to operate at a higher speed, the excess power can be used to provide a higher pressure. The power limit function will make sure that the motor load never exceeds its maximum by decreasing the speed until the motor is at its power limit.

In cases where an undersized motor is used with standard speed, the power limit function will still reduce the speed and protect the motor against overload at a high flow rate. The solution offers the following benefits:

- reduced motor size
- reduced pump size

Figure 37 shows that a pump operating at low flow rates and relatively high pressures (1) can be fitted with an undersize motor with a rated power that matches this operating range. At higher flow rates and relatively lower pressures (2), the motor will reduce its speed when the power limit is exceeded and follow a steeper curve corresponding to the power available.

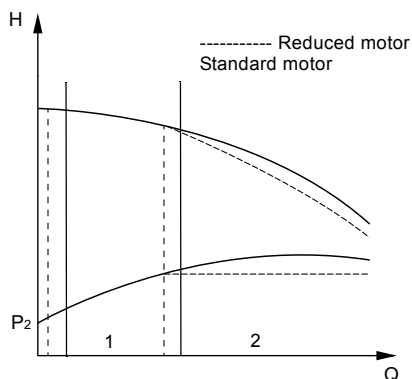

**Fig. 37** Standard performance curve compared to a curve for a pump fitted with an undersize MLE motor.

The MLE motor can be set to a higher speed than standard, enabling the pump to deliver more pressure. The pump will operate at this higher speed until the pump reaches the flow rate where the motor is loaded to its full rated power. If the flow rate is increased further, the motor will reduce its speed so as not to exceed its rated power.

Using this function can, in some instances, enable use of a smaller pump to reach the desired duty point compared to a pump running with standard maximum speed, see fig. 38.

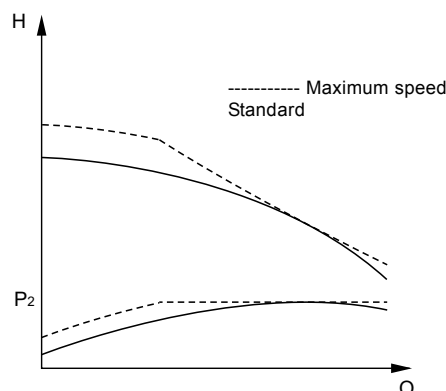

**Fig. 38** Standard performance curve (60 Hz) compared to a performance curve for a pump running at maximum speed.

### Applications

The power limit function is primarily used in applications where the motor size is dimensioned to be as small as possible to reduce size or cost. Or in applications demanding a high maximum speed to achieve a high pressure at a low flow rate. In both cases, the motor is protected by the power limit function at a higher flow rate where a lower speed is needed to prevent the motor from overloading.

#### Examples of application:

- Washing and clearing
- Boiler feed

#### Setup

The power limit is always active in CRE pumps to protect the motor against overload. Pumps with undersized motor and pumps with higher maximum speed are available as factory-configured products.

**Note:** Running at over-synchronous speed will affect the NPSH value, sufficient inlet pressure is therefore required.

Sound pressure level emitted from the pump and motor may increase at higher speeds.

Furthermore, the differential pressure over the chambers must be taken into consideration.

### Stabilizing unstable pump curves

When the pump curve has a shape where it intersects the system curve at two points (A and B) with identical pressure but at different flow rates, the pump curve is defined as unstable, see fig. 39. This is especially problematic in systems with a flat system characteristic as it prevents the pump from being controlled to a flow rate which is lower than the flow rate at point B.

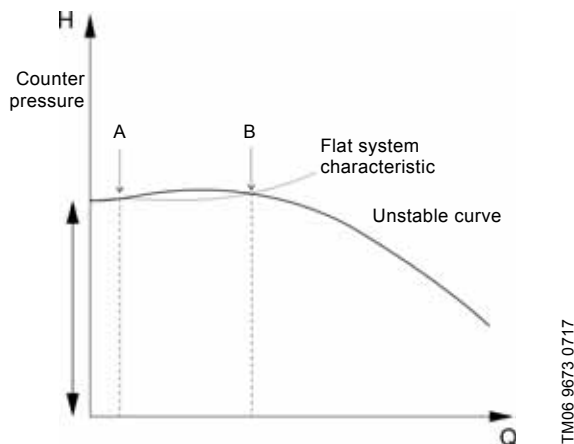

Fig. 39 Unstable pump curve

The E-motor can stabilize an unstable pump curve in the low flow area by changing to a higher speed. Fig. 40 illustrates how the pump curve is straightened out in this area. As the flow rate increases, the E-motor gradually reduces the speed to normal speed and the pump performance will follow the standard pump curve.

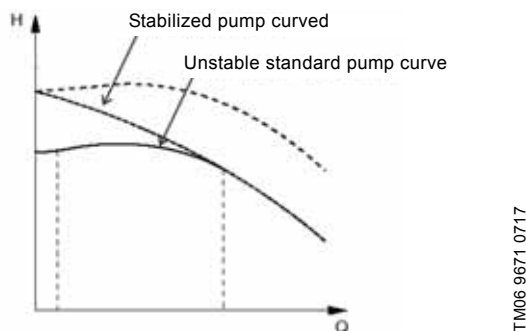

Fig. 40 Pump curve with a stabilized operating range

### Purpose and benefits

The purpose of stabilizing an unstable pump is to enable normal control throughout the entire operating range. Thus fully stable operation is achieved, even in the low flow range. This enables the use of modern high-efficiency pumps in applications where this would otherwise not be possible.

### Applications

As mentioned unstable operation may occur in applications with a high counterpressure and a flat system characteristic.

### Examples of application:

- pumping of water to a water tower
- boiler feed

**Note:** Sound pressure level emitted from the pump and motor may increase at higher speeds.

### Setup

This function is available in factory-configured products.

# 10. Construction

## CR, CRE 1s, 1, 3, 5, 10, 15 and 20 H



TM04 4524 1509

Fig. 41 Product photo

### Sectional drawing

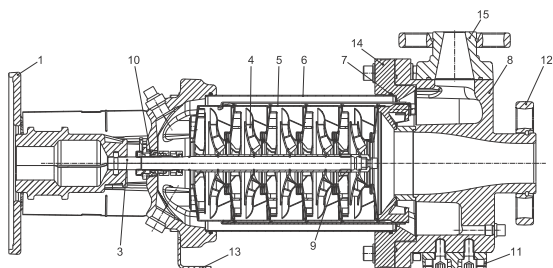

TM04 4269 4910

Fig. 42 Sectional drawing

### Material specification

#### CR-H, CRE-H

Pos.	Designation	Materials	AISI/ASTM
1	Pump head	Cast iron	A 48-30 B
3	Shaft	Stainless steel	AISI 316 <sup>1)</sup> AISI 431 <sup>2)</sup>
4	Impeller	Stainless steel	AISI 304
5	Chamber	Stainless steel	AISI 304
6	Outer sleeve	Stainless steel	AISI 304
7	O-ring for outer sleeve	EPDM or FKM	
8	Inlet-outlet housing	Ductile iron	A 80-55-06
9	Neck ring	PTFE	
10	Shaft seal	Cartridge type	
	Bearing rings	Silicon carbide	
	Rubber parts	EPDM or FKM	
11	Foot	Ductile iron	A 80-55-06
12	Flange ring	Ductile iron	A 80-55-06
13	Support bracket	Stainless steel	AISI 304
14	Sleeve flange <sup>5)</sup>	Stainless steel	CF 8M <sup>4)</sup>
15	Outlet port	Ductile iron	A 80-55-06

- 1) CR-H, CRE-H 1s, 1, 3, 5
- 2) CR-H, CRE-H 10, 15, 20
- 3) Stainless steel available on request
- 4) CF 8M is cast equivalent of AISI 316 stainless steel
- 5) CR-H, CRE-H 10, 15, 20 only; CR-H, CRE-H 1s, 1, 3, 5 do not have a sleeve flange.
- 6) CRN-H, CRNE-H 1s, 1, 3, 5
- 7) CRN-H, CRNE-H 10, 15, 20

## CRN, CRNE 1s, 1, 3, 5, 10, 15 and 20 H



TM04 9547 4510

Fig. 43 Product photo

### Sectional drawing

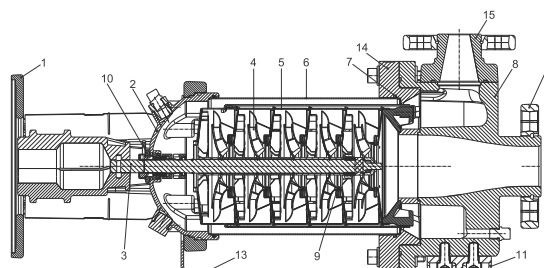

TM04 9676 4910

Fig. 44 Sectional drawing

### Material specification

#### CRN-H, CRNE-H

Pos.	Designation	Materials	AISI/ASTM
1	Pump head	Cast iron <sup>3)</sup>	A 48-30 B
2	Pump head cover	Stainless steel	CF 8M <sup>4)</sup>
3	Shaft	Stainless steel	AISI 316 <sup>6)</sup> AISI 329 <sup>7)</sup>
4	Impeller	Stainless steel	AISI 316
5	Chamber	Stainless steel	AISI 316
6	Outer sleeve	Stainless steel	AISI 316
7	O-ring for outer sleeve	EPDM or FKM	
8	Inlet-outlet housing	Stainless steel	CF 8M <sup>4)</sup>
9	Neck ring	PTFE	
10	Shaft seal	Cartridge type	
	Bearing rings	Silicon carbide	
	Rubber parts	EPDM or FKM	
11	Foot	Cast iron <sup>3)</sup>	A 48-30 B
12	Flange ring	Ductile iron <sup>3)</sup>	A 65-45-12
13	Support bracket	Stainless steel	AISI 304
14	Sleeve flange	Stainless steel	CF 8M <sup>4)</sup>
15	Outlet port	Stainless steel	CF 8M <sup>4)</sup>

**CR, CRE 32, 45, 64, and 90 H**



TM04 4525 1509

Fig. 45 Product photo

**Sectional drawing**

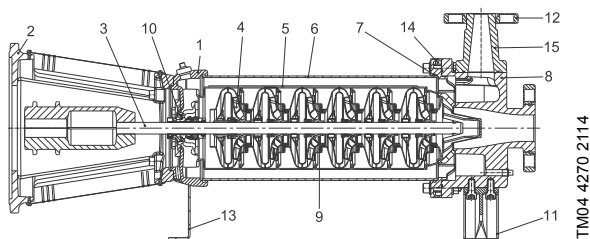

TM04 4270 2114

Fig. 46 Sectional drawing

**Material specification**

**CR-H, CRE-H**

Pos.	Designation	Materials	AISI/ASTM
1	Pump head	Ductile iron	A 80-55-06
2	Motor stool	Cast iron	A 48-30 B
3	Shaft	Stainless steel	AISI 431
4	Impeller	Stainless steel	AISI 304
5	Chamber	Stainless steel	AISI 304
6	Outer sleeve	Stainless steel	AISI 304
7	O-ring for sleeve	EPDM or FKM	
8	Inlet-outlet housing	Ductile iron	A 80-55-06
9	Neck ring	Carbon-graphite filled PTFE	
10	Shaft seal	Cartridge type	
	Bearing ring	SiC/SiC	
	Rubber parts	EPDM or FKM	
11	Foot	Ductile iron	A 80-55-06
12	Flange ring	Ductile iron	A 80-55-06
13	Support bracket	Stainless steel	AISI 304
14	Sleeve flange	Stainless steel	CF 8M <sup>2)</sup>
15	Outlet port	Ductile iron	A 80-55-06

1) Stainless steel available on request  
 2) CF 8M is cast equivalent of AISI 316 stainless steel

**CRN, CRNE 32, 45, 64, and 90 H**



TM04 9548 4510

Fig. 47 Product photo

**Sectional drawing**

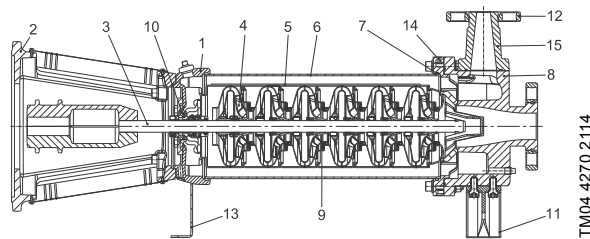

TM04 4270 2114

Fig. 48 Sectional drawing

**Material specification**

**CRN-H, CRNE-H**

Pos.	Designation	Materials	AISI/ASTM
1	Pump head	Stainless steel	CF 8M <sup>2)</sup>
2	Motor stool	Cast iron	A 48-30 B
3	Shaft	Stainless steel	SAF 2205
4	Impeller	Stainless steel	AISI 316
5	Chamber	Stainless steel	AISI 316
6	Outer sleeve	Stainless steel	AISI 316
7	O-ring for sleeve	EPDM or FKM	
8	Inlet-outlet housing	Stainless steel	CF 8M <sup>2)</sup>
9	Neck ring	Carbon-graphite filled PTFE	
10	Shaft seal	Cartridge type	
	Bearing ring	SiC/SiC	
	Rubber parts	EPDM or FKM	
11	Foot	Ductile iron <sup>1)</sup>	A 80-55-06
12	Flange ring	Ductile iron <sup>1)</sup>	A 65-45-12
13	Support bracket	Stainless steel	AISI 304
14	Sleeve flange	Stainless steel	CF 8M <sup>2)</sup>
15	Outlet port	Stainless steel	CF 8M <sup>2)</sup>

## 11. Operating conditions

### Pumped liquids

We recommend CR(E)-H, CRN(E)-H pumps for thin, non-explosive liquids, not containing solid particles or fibers. The liquid must not chemically attack the pump materials. When pumping liquids with a density and/or viscosity higher than that of water, oversized motors may be used, if required.

Whether a pump is suitable for a particular liquid depends on a number of factors including the chloride content, pH value, temperature and content of chemicals, oils, etc.

Please note that aggressive liquids (e.g. sea water and some acids) may attack or dissolve the protective oxide film of the stainless steel and thus cause corrosion. The CR(E)-H, CRN(E)-H pump types are suitable for pumping the following:

#### CR-H, CRE-H

#### Non-corrosive liquids

For fluid transfer, circulation and pressure boosting of cold or hot, clean water or other non-corrosive liquids.

#### CRN-H, CRNE-H

- Industrial liquids

In systems where all parts in contact with the pumped liquid must be made of high-grade stainless steel.

### List of pumped liquids

A number of typical liquids are listed on the following pages.

Other pump versions may be applicable, but those stated in the list are considered to be the best choices. The table is intended as a general guide only, and cannot replace actual testing of the pumped liquids and pump materials under specific working conditions. The list should, however, be applied with some caution as factors such as the following may affect the chemical resistance of a specific pump version:

- concentration of the pumped liquid
- liquid temperature
- pressure.

Safety precautions must be observed when pumping dangerous liquids.

The notes in this list apply to the table on the following page.

<b>D</b>	Often with additives.
<b>E</b>	Density and/or viscosity differ from that of water. Allow for this when calculating motor output and pump performance.
<b>F</b>	Pump selection depends on many factors. Contact Grundfos.
<b>H</b>	Risk of crystallization/precipitation in shaft seal
<b>1</b>	The pumped liquid is highly flammable.
<b>2</b>	The pumped liquid is combustible.
<b>3</b>	Insoluble in water.
<b>4</b>	Low self-ignition point.

Pumped liquid	Note	Liquid concentration, liquid temperature	CR		CRN	
			1s, 1, 3, 5, 10, 15, 20	32, 45, 64, 90, 120, 150	1s, 1, 3, 5, 10, 15, 20	32, 45, 64, 90, 120, 150
Acetic acid CH <sub>3</sub> COOH		5 %, 68 °F			HQQE	HQQE/HBQE
Acetone CH <sub>3</sub> COCH <sub>3</sub>	1, F	100 %, 68 °F			HBQE	HQQE/HBQE
Alkaline degreasing agent	D, F		HQQE	HQQE/HBQE		
Ammonium bicarbonate NH <sub>4</sub> HCO <sub>3</sub>	E	20 %, 86 °F			HQQE	HQQE/HBQE
Ammonium hydroxide NH <sub>4</sub> OH		20 %, 104 °F	HQQE	HQQE/HBQE		
Aviation fuel	1, 3, 4, F	100 %, 68 °F	HQBV	HQQV/HBQV		
Benzoic acid C <sub>6</sub> H <sub>5</sub> COOH	H	0.5 %, 68 °F			HQQV	HQQV/HBQV
Boiler water		< 248 °F	HQQE	HQQE/HBQE		
	F	248 °F - 356 °F	-	-		
Calcareous water		< 194 °F	HQQE	HQQE		
Calcium acetate (as coolant with inhibitor) Ca(CH <sub>3</sub> COO) <sub>2</sub>	D, E	30 %, 122 °F	HQQE	HQQE		
Calcium hydroxide Ca(OH) <sub>2</sub>	E	Saturated solution, 122 °F	HQQE	HQQE		
Chloride-containing water	F	< 86 °F, max. 500 ppm			HQQE	HQQE
Chromic acid H <sub>2</sub> CrO <sub>4</sub>	H	1 %, 68 °F			HQQV	HQQV/HBQV
Citric acid HOC(CH <sub>2</sub> CO <sub>2</sub> H) <sub>2</sub> COOH	H	5 %, 104 °F			HQQE	HQQE/HBQE
Completely desalinated water (demineralized water)		< 248 °F			HQQE	HQQE/HBQE
Condensate		< 194 °F	HQQE	HQQE/HBQE		
Copper sulfate CuSO <sub>4</sub>	E	10 %, 122 °F			HQQE	HQQE
Corn oil	D, E, 3	100 %, 176 °F	HQQV	HQQV/HBQV		
Diesel oil	2, 3, 4, F	100 %, 68 °F	HQBV	HQQV/HBQV		
Domestic hot water (potable water)		< 248 °F	HQQE	HQQE/HBQE		
Ethanol (ethyl alcohol) C <sub>2</sub> H <sub>5</sub> OH	1, F	100 %, 68 °F	HQQE	HQQE/HBQE		
Ethylene glycol HOCH <sub>2</sub> CH <sub>2</sub> OH	D, E	50 %, 122 °F	HQQE	HQQE		
Formic acid HCOOH		5 %, 68 °F			HQQE	HQQE/HBQE
Glycerine (glycerol) OHCH <sub>2</sub> CH(OH)CH <sub>2</sub> OH	D, E	50 %, 122 °F	HQQE	HQQE/HBQE		
Hydraulic oil (mineral)	E, 2, 3	100 %, 212 °F	HQQV	HQQV/HBQE		
Hydraulic oil (synthetic)	E, 2, 3	100 %, 212 °F	HQQV	HQQV/HBQE		
Isopropyl alcohol CH <sub>3</sub> CHOHCH <sub>3</sub>	1, F	100 %, 68 °F	HQBV	HQQV/HBQV		
Lactic acid CH <sub>3</sub> CH(OH)COOH	E, H	10 %, 68 °F			HQQE	HQQE/HBQE
Linoleic acid C <sub>17</sub> H <sub>31</sub> COOH	E, 3	100 %, 68 °F	HQQV	HQQV/HBQV		
Methanol (methyl alcohol) CH <sub>3</sub> OH	1, F	100 %, 68 °F	HQQE	HQQE/HBQE		
Motor oil	E, 2, 3	100 %, 176 °F	HQQV	HQQV/HBQV		
Naphthalene C <sub>10</sub> H <sub>8</sub>	E, H	100 %, 176 °F	HQQV	HQQV/HBQV		
Nitric acid HNO <sub>3</sub>	F	1 %, 68 °F			HQQE	HQQE/HBQE
Oil-containing water		< 212 °F	HQQV	HQQV/HBQV		
Olive oil	D, E, 3	100 %, 176 °F	HQQV	HQQV/HBQV		
Oxalic acid (COOH) <sub>2</sub>	H	1 %, 68 °F			HQQE	HQQE/HBQE
Ozone-containing water (O <sub>3</sub> )		1 PPM, < 105 °F			HQQE	HQQE/HBQE
Peanut oil	D, E, 3	100 %, 194 °F	HQQV	HQQV/HBQV		
Petrol/gasoline	1, 3, 4, F	100 %, 68 °F	HQBV	HQQV/HBQV		
Phosphoric acid H <sub>3</sub> PO <sub>4</sub>	E	20 %, 68 °F			HQQV	HQQV/HBQV
Propanol C <sub>3</sub> H <sub>7</sub> OH	1, F	100 %, 68 °F	HQQV	HQQV/HBQV		
Propylene glycol CH <sub>3</sub> CH(OH)CH <sub>2</sub> OH	D, E	50 %, 194 °F	HQQE	HQQE		
Potassium carbonate K <sub>2</sub> CO <sub>3</sub>	E	20 %, 122 °F	HQQE	HQQE		
Potassium formate (as coolant with inhibitor) KOOCH	D, E	30 %, 122 °F	HQQE	HQQE		
Potassium hydroxide KOH	E	20 %, 122 °F			HQQE	HQQE
Potassium permanganate KmnO <sub>4</sub>		5 %, 68 °F			HQQE	HQQE/HBQE
Rape seed oil	D, E, 3	100 %, 176 °F	HQQV	HQQV/HBQV		
Salicylic acid C <sub>6</sub> H <sub>4</sub> (OH)COOH	H	0.1 %, 68 °F			HQQE	HQQE/HBQE
Silicone oil	E, 3	100 %	HQQV	HQQV/HBQV		
Sodium bicarbonate NaHCO <sub>3</sub>	E	10 %, 140 °F			HQQE	HQQE/HBQE
Sodium chloride (as coolant) NaCl	D, E	30 %, < 41 °F, pH > 8	HQQE	HQQE		
Sodium hydroxide NaOH	E	20 %, 122 °F			HQQE	HQQE
Sodium hypochlorite NaOCl	F	0.1 %, 68 °F			HQQE	HQQE
Sodium nitrate NaNO <sub>3</sub>	E	10 %, 140 °F			HQQE	HQQE/HBQE

Pumped liquid	Note	Liquid concentration, liquid temperature	CR		CRN	
			1s, 1, 3, 5, 10, 15, 20	32, 45, 64, 90, 120, 150	1s, 1, 3, 5, 10, 15, 20	32, 45, 64, 90, 120, 150
Sodium phosphate $\text{Na}_3\text{PO}_4$	E, H	10 %, 140 °F			HQQE	HQQE
Sodium sulfate $\text{Na}_2\text{SO}_4$	E, H	10 %, 140 °F			HQQE	HQQE/HBQE
Softened water		< 248 °F			HQQE	HQQE/HBQE
Soybean oil	D, E, 3	100 %, 176 °F	HQQV	HQQV/HBQV		
Sulfuric acid $\text{H}_2\text{SO}_4$	F	1 %, 68 °F			HQQV	HQQV/HQQV
Sulfurous acid $\text{H}_2\text{SO}_3$		1 %, 68 °F			HQQE	HQQE/HBQE
Swimming pool water (low chloride)		Max 5 ppm free chlorine ( $\text{Cl}_2$ )	HQQE	HQQE/HBQE		

## Maximum operating pressure and temperature range

## ANSI flanged

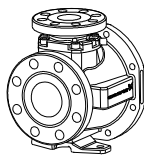

TM04 4039 0609

Pump type			Operating pressure	Liquid temperature range
CR(E), CRN(E) 1s-2 H	→	1s-17 H	232 psi (16 bar)*	
CR(E), CRN(E) 1s-19 H	→	1s-27 H	362 psi (25 bar)	
CR(E), CRN(E) 1-2 H	→	1-17 H	232 psi (16 bar)*	
CR(E), CRN(E) 1-19 H	→	1-27 H	362 psi (25 bar)	
CR(E), CRN(E) 3-2 H	→	3-15 H	232 psi (16 bar)*	(-4 °F to +248 °F) (-20 °C to +120 °C)
CR(E), CRN(E) 3-17 H	→	3-25 H	362 psi (25 bar)	
CR(E), CRN(E) 5-2 H	→	5-15 H	232 psi (16 bar)*	
CR(E), CRN(E) 5-16 H	→	5-24 H	362 psi (25 bar)	
CR(E), CRN(E) 10-1 H	→	10-10 H	232 psi (16 bar)*	
CR(E), CRN(E) 10-12 H	→	10-17 H	362 psi (25 bar)	
CR(E), CRN(E) 15-1 H	→	15-8 H	232 psi (16 bar)*	
CR, CRN 15-9 H	→	15-12 H	362 psi (25 bar)	(-4 °F to +248 °F) (-20 °C to +120 °C)
CR(E), CRN(E) 20-1 H	→	20-7 H	232 psi (16 bar)*	
CR, CRN 20-8 H	→	20-10 H	362 psi (25 bar)	
CR(E), CRN(E) 32-1-1 H	→	32-5 H	232 psi (16 bar)*	
CR, CRN 32-6-2 H	→	32-11-2 H	435 psi (30 bar)	
CR(E), CRN(E) 45-1-1 H	→	45-4 H	232 psi (16 bar)*	
CR, CRN 45-5-2 H	→	45-8-1 H	435 psi (30 bar)	(-22 °F to +248 °F) (-30 °C to +120 °C)
CR(E), CRN(E) 64-1-1 H	→	64-3 H	232 psi (16 bar)*	
CR, CRN 64-4-2 H	→	64-5-2 H	435 psi (30 bar)	
CR, CRN 90-1-1 H	→	90-3 H	232 psi (16 bar)*	
CR, CRN 90-4-2 H	→	90-4-1 H	435 psi (30 bar)	

\* These pumps come standard with 125/150 lb. ANSI flanges. High pressure versions are available which will raise the operating pressure to the next rating.

### Operating range of the shaft seal

The operating range of the shaft seal depends on operating pressure, pump type, type of shaft seal and liquid temperature. The following curves apply to clean water and water with anti-freeze liquids. For selecting the right shaft seal, see [List of pumped liquids](#) on page 36.

#### CR(E), CRN(E) 1s H through CR(E), CRN(E) 20 H

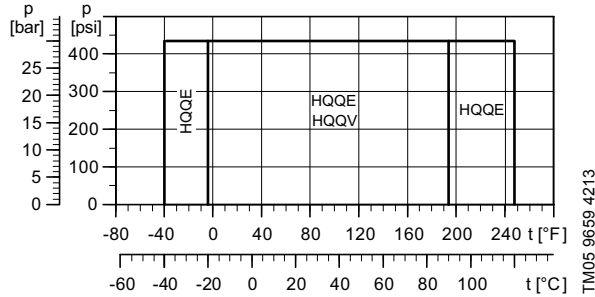

Fig. 49 Operating range of standard shaft seals for CR(E), CRN(E) 1s H to CR(E), CRN(E) 20 H

#### CR(E), CRN(E) 32 H through CR, CRN 90 H

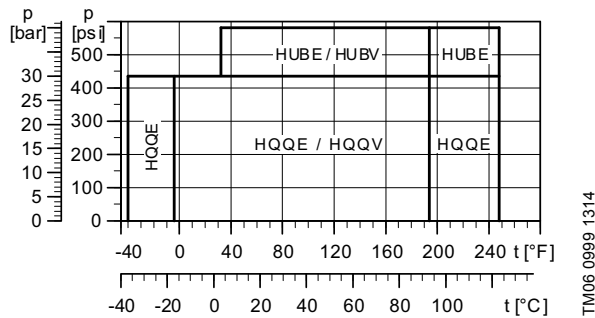

Fig. 50 Operating range of standard shaft seals for CR(E), CRN(E) 32 H to CR, CRN 90 H

Shaft seal	Description	Max. temp. range [°F]
HQQE	O-ring (cartridge) (balanced seal), SiC/SiC, EPDM	-40 to +248 °F
HBQE	O-ring (cartridge) (balanced seal), Carbon/SiC, EPDM	+32 to +248 °F
HBQV	O-ring (cartridge) (balanced seal), Carbon/SiC, FKM	+32 to +194 °F
HQQV	O-ring (cartridge) (balanced seal), SiC/SiC, FKM	-4 to +194 °F
HUBE	O-ring (cartridge) (balanced seal), TC/carbon, EPDM	+32 to +248 °F
HUBV	O-ring (cartridge) (balanced seal), TC/carbon, FKM	+32 to +194 °F

TC = tungsten carbide.

The pumping of liquids above 248 °F (120 °C) may result in periodical noise and reduced pump life. Standard CR-H, CRN-H pumps are not suitable for the pumping of liquids above 248 °F (120 °C) for long periods.

See the Grundfos "Custom-built Pumps" Product Guide for information about pumps for extreme temperatures and special conditions.

## Maximum inlet pressure

The following table shows the maximum permissible inlet pressure. However, the current inlet pressure + the pressure against closed valve **must** always be lower than the maximum permissible operating pressure.

If the maximum permissible operating pressure is exceeded, the bearing in the motor may be damaged and the life of the shaft seal reduced.

Maximum inlet pressure CR(E)-H, CRN(E)-H	
<b>CR(E), CRN(E) 1s H</b>	
CR 1s-2 H → CR 1s-27 H	145 psi (10 bar)
<b>CR(E), CRN(E) 1 H</b>	
CR 1-2 H → CR 1-25 H	145 psi (10 bar)
CR 1-27 H	217 psi (15 bar)
<b>CR(E), CRN(E) 3 H</b>	
CR 3-2 H → CR 3-15 H	145 psi (10 bar)
CR 3-17 H → CR 3-25 H	217 psi (15 bar)
<b>CR(E), CRN(E) 5 H</b>	
CR 5-2 H → CR 5-9 H	145 psi (10 bar)
CR 5-10 H → CR 5-24 H	217 psi (15 bar)
<b>CR(E), CRN(E) 10 H</b>	
CR 10-1 H → CR 10-5 H	116 psi (8 bar)
CR 10-6 H → CR 10-17 H	145 psi (10 bar)
<b>CR(E), CRN(E) 15 H</b>	
CR 15-1 H → CR 15-2 H	116 psi (8 bar)
CR 15-3 H → CR 15-12 H	145 psi (10 bar)
<b>CR(E), CRN(E) 20 H</b>	
CR 20-1 H	116 psi (8 bar)
CR 20-2 H → CR 20-10 H	145 psi (10 bar)
<b>CR(E), CRN(E) 32 H</b>	
CR 32-1-1 H → CR 32-2 H	58 psi (4 bar)
CR 32-3-2 H → CR 32-6 H	145 psi (10 bar)
CR 32-7-2 H → CR 32-11-2 H	217 psi (15 bar)
<b>CR(E), CRN(E) 45 H</b>	
CR 45-1-1 H → CR 45-1 H	58 psi (4 bar)
CR 45-2-2 H → CR 45-3 H	145 psi (10 bar)
CR 45-4-2 H → CR 45-8-1 H	217 psi (15 bar)
<b>CR(E), CRN(E) 64 H</b>	
CR 64-1-1 H	58 psi (4 bar)
CR 64-1 H → CR 64-2-1 H	145 psi (10 bar)
CR 64-2 H → CR 64-5-2 H	217 psi (15 bar)
<b>CR, CRN 90 H</b>	
CR 90-1-1 H → CR 90-2-2 H	145 psi (10 bar)
CR 90-2-1 H → CR 90-4-1 H	217 psi (15 bar)

## Example of operating and inlet pressures

The values for operating and inlet pressures shown in the tables must not be considered individually but must always be compared; see the following examples:

### Example 1:

The following pump type has been selected:  
CR 5-20 H-GA-A-E

Maximum operating pressure: **362 psi (25 bar)**

Maximum inlet pressure: **217 psi (15 bar)**

Outlet pressure against closed valve:  
**282 psi (652 ft)**. See page 54.

This pump is not allowed to start at an inlet pressure of 217 psi, but at an inlet pressure of:  
 $362 - 282 = 80$  **psi (5.5 bar)**.

### Example 2:

The following pump has been selected:  
CR 10-2 H-G05-A-E

Maximum operating pressure: **232 psi (16 bar)**

Maximum inlet pressure: **116 psi (8 bar)**

Outlet pressure against closed valve:  
**42 psi (97 ft)**. See page 56.

This pump is allowed to start at an inlet pressure of 116 psi (8 bar), as the outlet pressure is only 42 psi (2.9 bar), which results in an operating pressure of  $116 + 42 = 158$  **psi (11 bar)**. On the contrary, the maximum operating pressure of this pump is limited to 158 psi (11 bar), as a higher operating pressure will require an inlet pressure of more than 116 psi (8 bar).

# 12. Selection and sizing

## Selection of pumps

Selection of pumps should be based on:

- duty point of the pump
- sizing data such as pressure loss as a result of height differences, friction loss in the pipes, pump efficiency etc.
- pump materials
- pipe dimensions
- shaft seal
- inlet pressure and operating pressure.

## Duty point of the pump

From a duty point it is possible to select a pump on the basis of the curve charts in the section [13. Curve charts/technical data](#) starting on page 48.

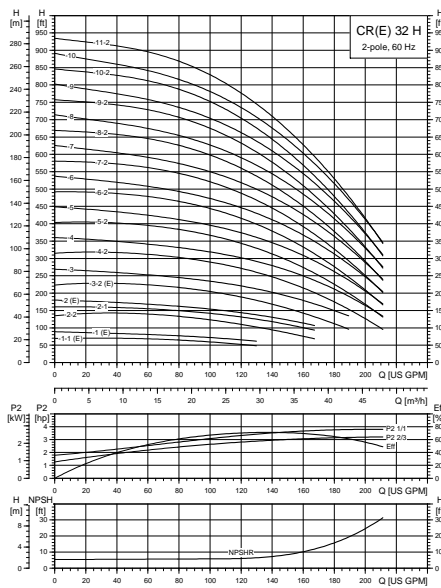

Fig. 51 Example of a curve chart

## Sizing data

When sizing a pump the following must be taken into account.

- Required flow rate and pressure at the point of use.
- Pressure loss as a result of height differences ( $H_{geo}$ ).
- Friction loss in the pipes ( $H_f$ ). It may be necessary to account for pressure loss in connection with long pipes, bends or valves, etc.
- Best efficiency at the estimated duty point.
- NPSH value. For calculation of the NPSH value, see [Minimum inlet pressure, NPSHA](#) on page 45.

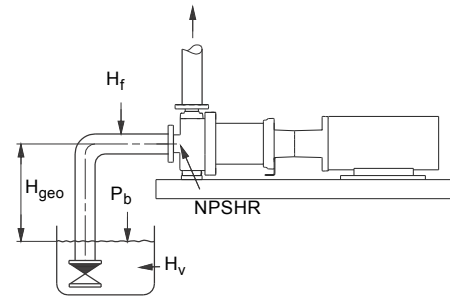

Fig. 52 Sizing data

## Efficiency

Before determining the point of best efficiency, the operating pattern of the pump must be identified. If the pump is expected to operate in the same duty point, then select a CR(E)-H, CRN(E)-H pump which is operating in a duty point corresponding to the best efficiency of the pump.

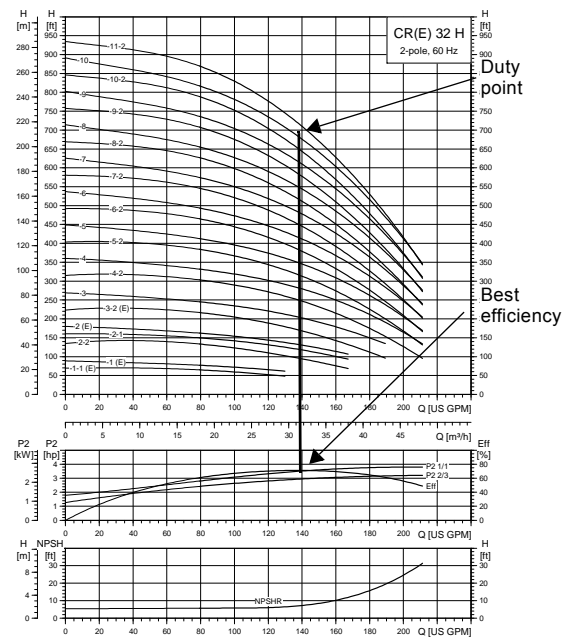

Fig. 53 Example of duty point

TM04 3689 4804

TM04 4551 1609

TM02 0039 1303

As the pump is sized on the basis of the highest possible flow rate, it is important to always have the duty point to the right of the optimum efficiency point (see fig. 54, range with check mark). This must be considered in order to keep efficiency high when the flow rate drops.

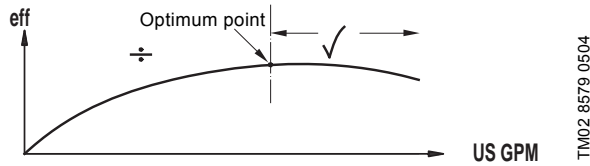

Fig. 54 Best efficiency

TM02 8579 0504

Normally, E-pumps are used in applications characterized by a variable flow rate. Consequently, it is not possible to select a pump that is constantly operating at optimum efficiency.

In order to achieve optimum operating economy, the pump should be selected on the basis of the following criteria:

- The maximum required duty point should be as close as possible to the QH curve of the pump.
- The required duty point must be positioned so that P2 is close to the maximum point of the 100 % curve.

Between the minimum and maximum performance curve E-pumps have an infinite number of performance curves each representing a specific speed. Therefore it may not be possible to select a duty point close to the 100 % curve.

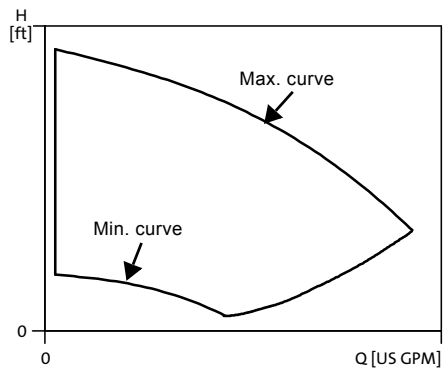

Fig. 55 Minimum and maximum performance curves

TM02 7572 4803

In situations where it is not possible to select a duty point close to the 100 % curve, the affinity equations to the right can be used. The head (H), the flow rate (Q) and the input power (P) are all the appropriate variables for the motor speed (n).

**Note:** The approximate formulas apply on condition that the system characteristic remains unchanged for  $n_n$  and  $n_x$ , and that it is based on the formula  $H = k \times Q_2$ , where k is a constant.

The power equation implies that the pump efficiency is unchanged at the two speeds. In practice this is **not** correct.

Finally, it is worth noting that the efficiencies of the frequency converter and the motor **must** be taken into account if a precise calculation of the power saving resulting from a reduction of the pump speed is wanted.

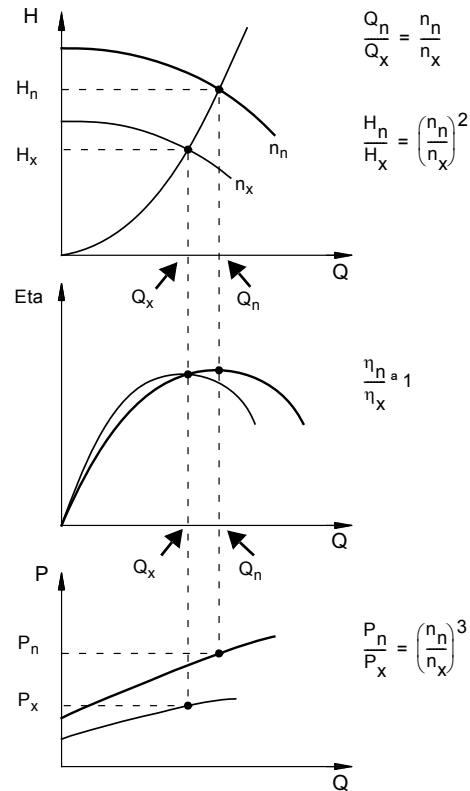

Fig. 56 Affinity equations

TM00 8720 3496

**Legend**

$H_n$	Rated head in feet
$H_x$	Current head in feet
$Q_n$	Rated flow rate in US gpm
$Q_x$	Current flow rate in US gpm
$n_n$	Rated motor speed in $\text{min}^{-1}$ ( $n_n = 3500 \text{ min}^{-1}$ )
$n_x$	Current motor speed in $\text{min}^{-1}$
$\eta_n$	Rated efficiency in %
$\eta_x$	Current efficiency in %

### Grundfos Product Center

We recommend that you size your pump in Grundfos Product Center, which is a selection program offered by Grundfos. For further information, see Grundfos Product Center.

Grundfos Product Center features a user-friendly and easy-to-use virtual guide which leads you through the selection of the pump for the application in question.

### Pump materials

The material variant should be selected based on the liquid to be pumped. The product range covers the following two basic types:

- The CR-H, CRE-H pump types are suitable for clean, non-aggressive liquids such as potable water, oils, etc.
- The CRN-H, CRNE-H pump types are suitable for industrial liquids and acids. See [List of pumped liquids](#) on page 36 or contact Grundfos.

### Pipe dimensions

CR(E)-H, CRN(E)-H pumps can be selected to comply with ANSI/ASME B73.1 pipes and most baseplate dimensions based on the ANSI/ASME B73.1.

CR(E)-H, CRN(E)-H pumps can also be selected with Grundfos end-suction pipe dimensions (GA is the only connector type available for CR, CRE 1s, 1, 3, 5 H pumps. See chart on page 11 for G22, G33, and G44 availability). When selecting your pump, please note:

	Pipe connection (inlet x outlet x impeller size reference)
GA	ANSI 1.5" x 1" x 6", 1.5" x 1" x 8"
G05	ANSI 2" x 1" x 10"
GB	ANSI 3" x 1.5" x 6", 3" x 1.5" x 8"
GC	ANSI 3" x 2" x 6"
G10	ANSI 3" x 2" x 6"
G50	ANSI 3" x 1.5" x 8", 3" x 1.5" x 10"
G60	ANSI 3" x 2" x 8", 3" x 2" x 10"
G20	ANSI 3" x 1.5" x 13"
G30	ANSI 3" x 2" x 13"
G70	ANSI 4" x 3" x 8", 4" x 3" x 10"
G40	ANSI 4" x 3" x 10", 4" x 3" x 13"
G22	ANSI 2" x 2"
G33	ANSI 3" x 3"
G44	ANSI 4" x 4"

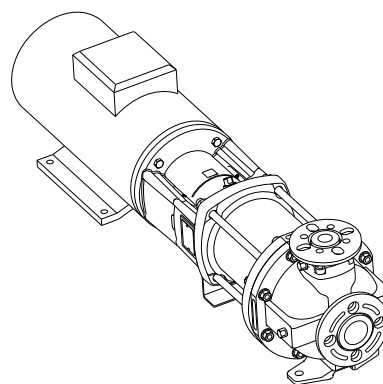

Fig. 57 CR-H pump

TM04 4539 1609

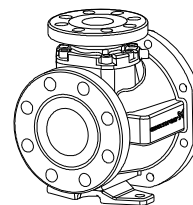

Fig. 58 Pump connections

TM04 4039 0609

### Shaft seal

As standard, the CR(E)-H, CRN(E)-H range is fitted with a Grundfos shaft seal (cartridge type) suitable for the most common applications. See fig. 59.

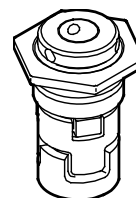

Fig. 59 Shaft seal (cartridge type)

TM02 0538 4800

The following three key parameters **must** be taken into account, when selecting the shaft seal:

- type of pumped liquid
- liquid temperature
- maximum pressure.

Grundfos offers a wide range of shaft seal variants to meet specific demands. See [List of pumped liquids](#) on page 36.

### Inlet pressure and operating pressure

Do **not** exceed the limit values stated on pages 39 and 41 as regards these pressures:

- maximum inlet pressure
- maximum operating pressure.

## Minimum inlet pressure, NPSHA

We recommend calculating the inlet pressure "H" in these situations:

- The liquid temperature is high.
- The flow rate is significantly higher than the rated flow rate.
- Water is drawn from depths.
- Water is drawn through long pipes.
- Inlet conditions are poor.

To avoid cavitation, make sure that there is a minimum pressure on the inlet side of the pump. The maximum suction lift "H" in feet can be calculated as follows:

$$H = p_b - \text{NPSHR} - H_f - H_v - H_s$$

$P_b$  = Barometric pressure in feet absolute.

(Barometric pressure can be set to 33.9 feet at sea level. In closed systems,  $p_b$  indicates system pressure in feet.)

NPSHR = Net Positive Suction Head Required in feet.

(To be read from the NPSHR curve at the highest flow rate the pump will be delivering).

$H_f$  = Friction loss in inlet pipe in feet.

(At the highest flow rate the pump will be delivering.)

$H_v$  = Vapor pressure in feet.

(To be read from the vapor pressure scale. " $H_v$ " depends on the liquid temperature " $T_m$ ").

$H_s$  = Safety margin = minimum 2.0 feet.

If the "H" calculated is positive, the pump can operate at a suction lift of maximum "H" feet.

If the "H" calculated is negative, an inlet pressure of minimum "H" feet is required.

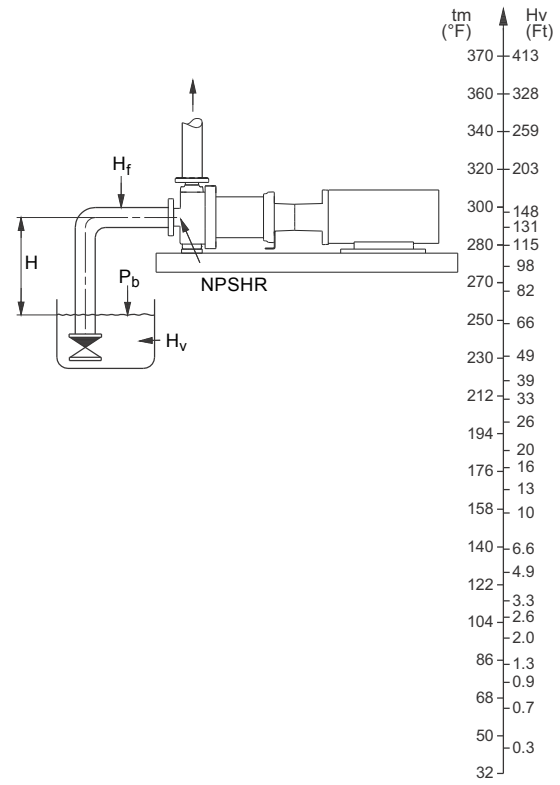

Fig. 60 Minimum inlet pressure - NPSHR

**Note:** In order to avoid cavitation **never** select a pump whose duty point lies too far to the right on the NPSHR curve.

Always check the NPSHR value of the pump at the highest possible flow rate. The NPSHR curves can be found in the curve charts starting on page 48.

## Maximum inlet pressure

The table on page 41 states the maximum permissible inlet pressure. However, the actual inlet pressure + maximum pump pressure (at shut-off) must always be lower than the values stated in the table on page 39.

The pumps are pressure-tested at a pressure of 1.5 times the values stated on page 39.

### How to read the curve charts

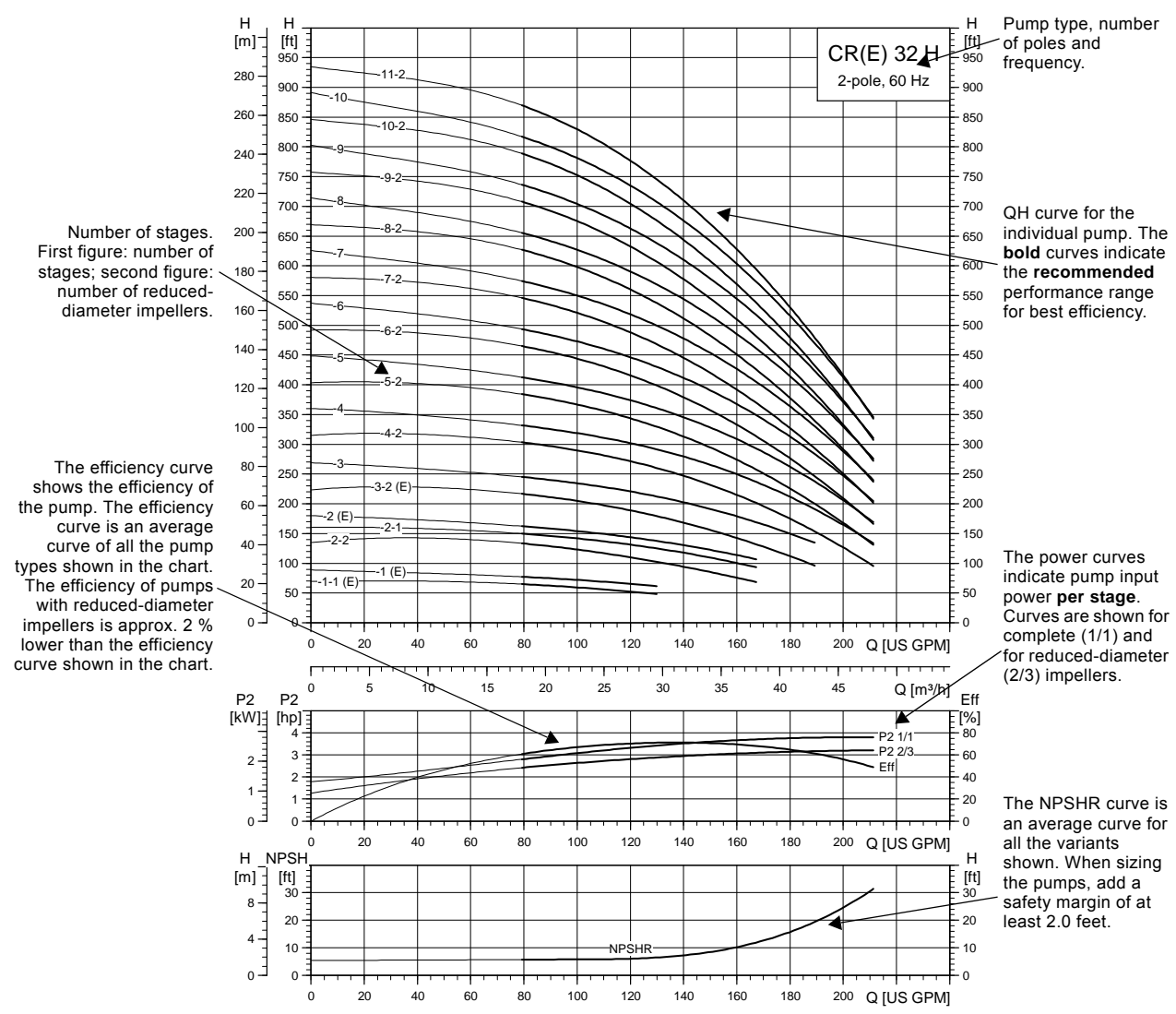

Fig. 61 How to read the curve charts

TM04 4551 1609

## Guidelines to performance curves

The guidelines below apply to the curves shown on the following pages:

- The motors used for the measurements are standard motors (TEFC or MLE).
- Measurements have been made with airless water at a temperature of 68 °F (20 °C).
- The curves apply to a kinematic viscosity of  $\nu = 1 \text{ mm}^2/\text{s}$  (1 cSt).
- Due to the risk of overheating, the pumps must not be used at a flow rate below the minimum flow rate.
- The QH curves apply to actual speed with the motor types mentioned at 60 Hz.

The curve below shows the minimum flow rate as a percentage of the nominal flow rate in relation to the liquid temperature. The dotted line shows a CR(E)-H, CRN(E)-H pump fitted with an air-cooled top assembly.

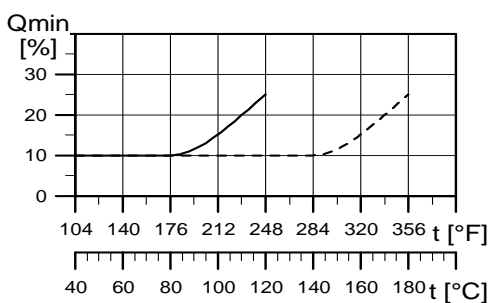

TM02 7538 3703

Fig. 62 Minimum flow rate

# 13. Curve charts/technical data

## CR, CRN 1s H GA

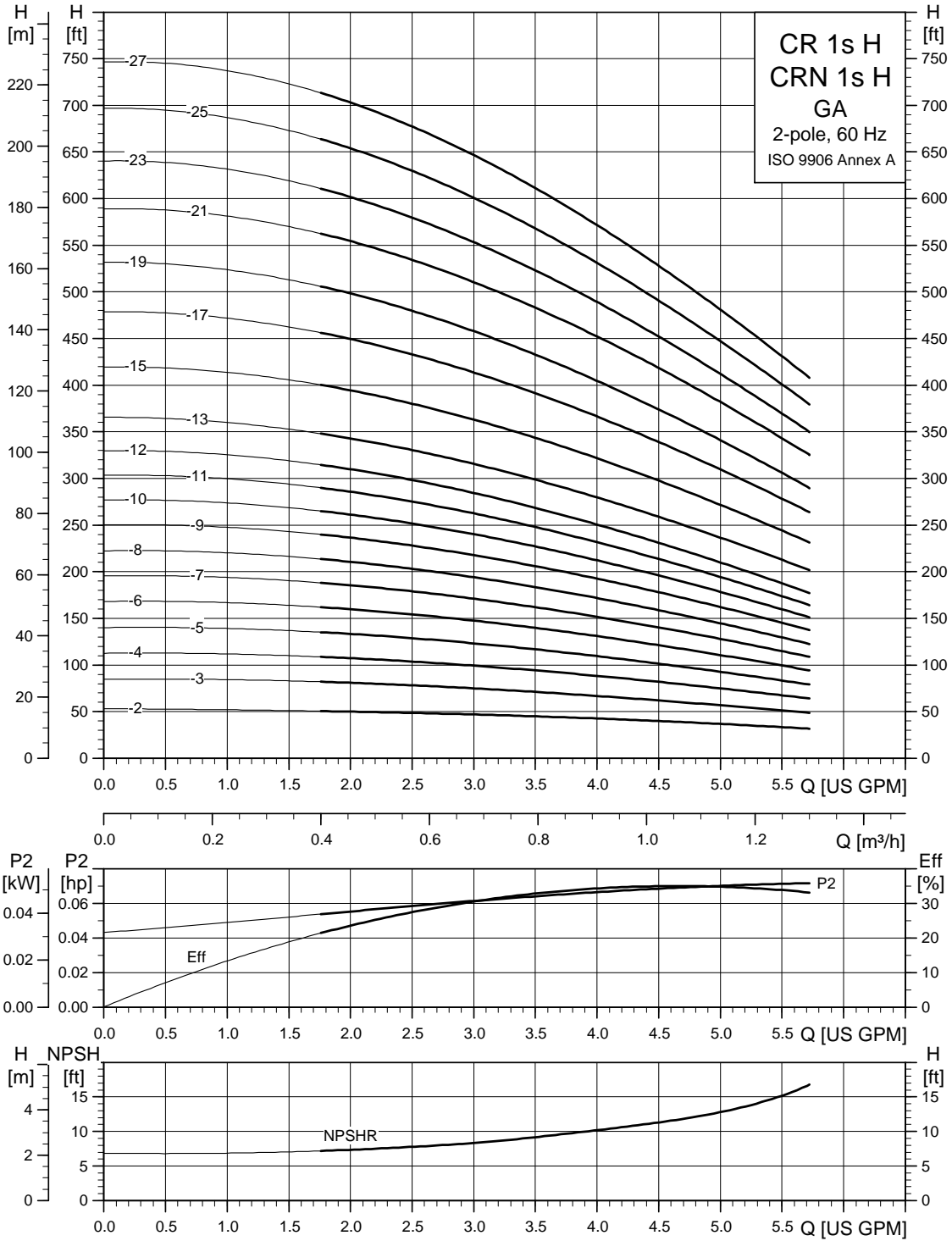

TM04 4545 4610

Dimensions and weights GA (1.5" x 1" x 6", 1.5" x 1" x 8")

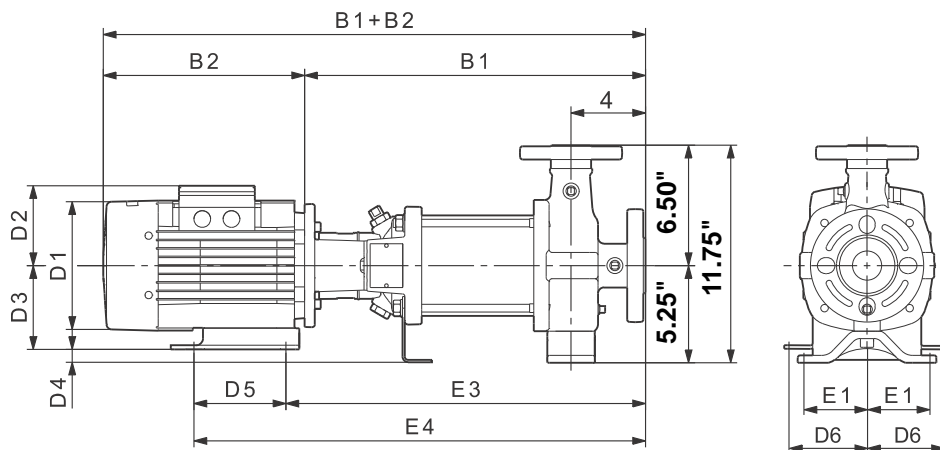

TM04 4642 0510

Pump type	HP	PH	Dimensions [inches]										Ship. wt. [lbs]	
			TEFC											
			B1	B1+B2	E1	E3	E4	D1	D2	D3	D4	D5		D6
CR(N) 1s-2 H	1/3	1	13.07	22.38	3.00	15.63	18.63	5.19	3.00	3.50	1.75	3.00	6.19	76
		3	13.07	20.69	3.00	15.63	18.63	4.63	3.50	3.50	1.75	3.00	5.57	73
CR(N) 1s-3 H	1/3	1	13.07	22.38	3.00	15.63	18.63	5.19	3.00	3.50	1.75	3.00	6.19	76
		3	13.07	20.69	3.00	15.63	18.63	4.63	3.50	3.50	1.75	3.00	5.57	73
CR(N) 1s-4 H	1/3	1	13.75	23.07	3.00	16.32	19.32	5.19	3.00	3.50	1.75	3.00	6.19	77
		3	13.75	21.38	3.00	16.32	19.32	4.63	3.50	3.50	1.75	3.00	5.57	74
CR(N) 1s-5 H	1/3	1	14.5	23.75	3.00	17.07	20.07	5.19	3.00	3.50	1.75	3.00	6.19	78
		3	14.5	22.07	3.00	17.07	20.07	4.63	3.50	3.50	1.75	3.00	5.57	75
CR(N) 1s-6 H	1/2	1	15.19	24.5	3.00	17.75	20.75	5.19	3.00	3.50	1.75	3.00	6.19	80
		3	15.19	22.82	3.00	17.75	20.75	4.63	3.50	3.50	1.75	3.00	5.57	76
CR(N) 1s-7 H	1/2	1	15.88	25.19	3.00	18.44	21.44	5.19	3.00	3.50	1.75	3.00	6.19	81
		3	15.88	23.50	3.00	18.44	21.44	4.63	3.50	3.50	1.75	3.00	5.57	77
CR(N) 1s-8 H	1/2	1	16.63	25.88	3.00	19.19	22.19	5.19	3.00	3.50	1.75	3.00	6.19	81
		3	16.63	24.19	3.00	19.19	22.19	4.63	3.50	3.50	1.75	3.00	5.57	77
CR(N) 1s-9 H	3/4	1	17.32	27.25	3.00	19.88	22.88	5.19	3.00	3.50	1.75	3.00	6.19	89
		3	17.32	24.94	3.00	19.88	22.88	4.63	3.50	3.50	1.75	3.00	5.57	79
CR(N) 1s-10 H	3/4	1	18.00	27.94	3.00	20.57	23.57	5.19	3.00	3.50	1.75	3.00	6.19	89
		3	18.00	25.63	3.00	20.57	23.57	4.63	3.50	3.50	1.75	3.00	5.57	79
CR(N) 1s-11 H	3/4	1	18.75	28.63	3.00	21.32	24.32	5.19	3.00	3.50	1.75	3.00	6.19	90
		3	18.75	26.32	3.00	21.32	24.32	4.63	3.50	3.50	1.75	3.00	5.57	80
CR(N) 1s-12 H	3/4	1	19.44	29.38	3.00	22.00	25.00	5.19	3.00	3.50	1.75	3.00	6.19	91
		3	19.44	27.07	3.00	22.00	25.00	4.63	3.50	3.50	1.75	3.00	5.57	81
CR(N) 1s-13 H	1	1	20.13	31.38	3.00	22.69	25.69	5.75	3.00	3.50	1.75	3.00	7.19	97
		3	20.13	27.75	3.00	22.69	25.69	4.63	3.50	3.50	1.75	3.00	5.57	82
CR(N) 1s-15 H	1	1	21.57	32.75	3.00	24.13	27.13	5.75	3.00	3.50	1.75	3.00	7.19	99
		3	21.57	29.19	3.00	24.13	27.13	4.63	3.50	3.50	1.75	3.00	5.57	84
CR(N) 1s-17 H	1 1/2	1	23.00	34.69	3.00	25.57	28.57	5.75	3.00	3.50	1.75	3.00	7.19	113
		3	23.00	31.75	3.00	25.57	28.57	4.63	3.50	3.50	1.75	3.00	5.57	86
CR(N) 1s-19 H	1 1/2	1	24.44	36.07	3.00	26.94	29.94	5.75	3.00	3.50	1.75	3.00	7.19	119
		3	24.44	33.19	3.00	26.94	29.94	4.63	3.50	3.50	1.75	3.00	5.57	92
CR(N) 1s-21 H	1 1/2	1	25.82	37.50	3.00	28.38	31.38	5.75	3.00	3.50	1.75	3.00	7.19	120
		3	25.82	34.63	3.00	28.38	31.38	4.63	3.50	3.50	1.75	3.00	5.57	93
CR(N) 1s-23 H	1 1/2	1	27.25	38.94	3.00	29.82	32.82	5.75	3.00	3.50	1.75	3.00	7.19	128
		3	27.25	36.00	3.00	29.82	32.82	4.63	3.50	3.50	1.75	3.00	5.57	101
CR(N) 1s-25 H	2	1	28.69	41.25	3.00	31.25	34.25	5.75	3.00	3.50	1.75	3.00	7.19	133
		3	28.69	40.07	3.00	31.25	34.25	4.38	3.50	3.50	1.75	3.00	7.07	124
CR(N) 1s-27 H	2	1	30.07	42.63	3.00	32.63	35.63	5.75	3.00	3.50	1.75	3.00	7.19	134
		3	30.07	41.44	3.00	32.63	35.63	4.38	3.50	3.50	1.75	3.00	7.07	125

Note: Terminal box is on top of ML motors (through 30 HP). Baldor motors have terminal box on the side (40 HP and larger). Reference D2 dimension.

**CR, CRE, CRN, CRNE 1 H GA**

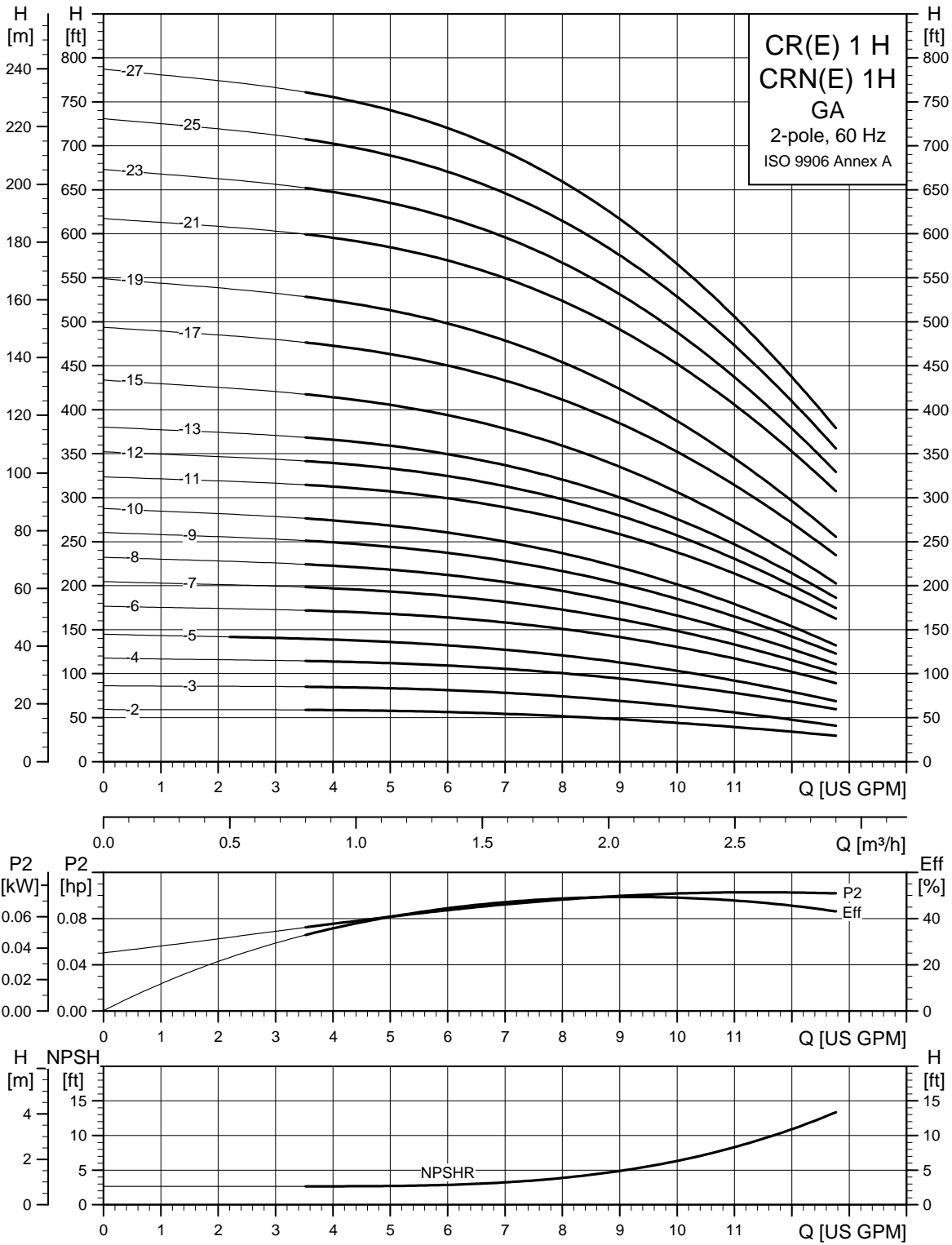

TM04 4546 0912

Dimensions GA (1.5" x 1" x 6", 1.5" x 1" x 8")

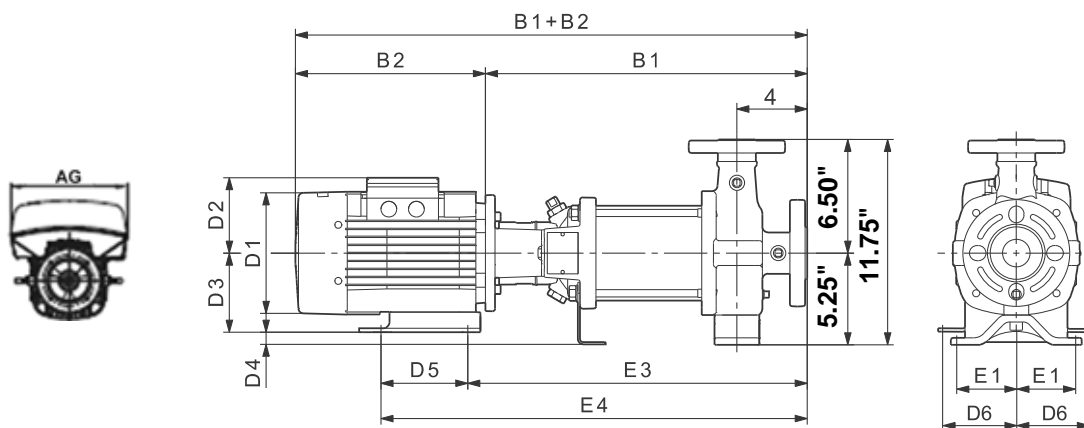

TM06 2478 1014 - TM04 4642 0310

Pump type	HP	PH	Dimensions [in] TEFC										Ship. wt. [lbs]	Dimensions [in] MLE*				Ship. wt. [lbs]	
			B1	B1+B2	E1	E3	E4	D1	D2	D3	D4	D5		D6	D1	D2	AG		B1+B2
CR(N) 1-2 H	1/3	1	13.07	22.38	3.00	15.63	18.63	5.19	3.00	3.50	1.75	3.00	6.19	76	-	-	-	-	-
		3	13.07	20.69	3.00	15.63	18.63	4.63	3.50	3.50	1.75	3.00	5.57	73	-	-	-	-	-
CR(N) 1-3 H	1/3	1	13.07	22.38	3.00	15.63	18.63	5.19	3.00	3.50	1.75	3.00	6.19	76	-	-	-	-	-
		3	13.07	20.69	3.00	15.63	18.63	4.63	3.50	3.50	1.75	3.00	5.57	73	-	-	-	-	-
CR(N)(E) 1-4 H	1/2	1	13.75	23.07	3.00	16.32	19.32	5.19	3.00	3.50	1.75	3.00	6.19	78	4.80	6.22	8.34	22.21	78
		3	13.75	21.38	3.00	16.32	19.32	4.63	3.50	3.50	1.75	3.00	5.57	74	-	-	-	-	-
CR(N) 1-5 H	1/2	1	14.50	23.75	3.00	17.07	20.07	5.19	3.00	3.50	1.75	3.00	6.19	79	-	-	-	-	-
		3	14.50	22.07	3.00	17.07	20.07	4.63	3.50	3.50	1.75	3.00	5.57	75	-	-	-	-	-
CR(N)(E) 1-6 H	3/4	1	15.19	25.13	3.00	17.75	20.75	5.19	3.00	3.50	1.75	3.00	6.19	86	4.80	6.22	8.34	23.65	80
		3	15.19	22.82	3.00	17.75	20.75	4.63	3.50	3.50	1.75	3.00	5.57	76	-	-	-	-	-
CR(N) 1-7 H	3/4	1	15.88	25.82	3.00	18.44	21.44	5.19	3.00	3.50	1.75	3.00	6.19	87	-	-	-	-	-
		3	15.88	23.50	3.00	18.44	21.44	4.63	3.50	3.50	1.75	3.00	5.57	77	-	-	-	-	-
CR(N) 1-8 H	1	1	16.63	27.82	3.00	19.19	22.19	5.75	3.00	3.50	1.75	3.00	7.19	93	-	-	-	-	-
		3	16.63	24.19	3.00	19.19	22.19	4.63	3.50	3.50	1.75	3.00	5.57	78	-	-	-	-	-
CR(N)(E) 1-9 H	1	1	17.32	28.50	3.00	19.88	22.88	5.75	3.00	3.50	1.75	3.00	7.19	94	4.80	6.22	10.56	25.78	83
		3	17.32	24.94	3.00	19.88	22.88	4.63	3.50	3.50	1.75	3.00	5.57	79	4.80	6.22	10.56	27.36	90
CR(N)(E) 1-10 H	1 1/2	1	18.00	29.69	3.00	20.57	23.57	5.75	3.00	3.50	1.75	3.00	7.19	108	4.80	6.22	8.34	26.46	86
		3	18.00	26.82	3.00	20.57	23.57	4.63	3.50	3.50	1.75	3.00	5.57	81	4.80	6.22	10.56	28.04	91
CR(N) 1-11 H	1 1/2	1	18.75	30.44	3.00	21.32	24.32	5.75	3.00	3.50	1.75	3.00	7.19	108	-	-	-	-	-
		3	18.75	27.50	3.00	21.32	24.32	4.63	3.50	3.50	1.75	3.00	5.57	81	-	-	-	-	-
CR(N) 1-12 H	1 1/2	1	19.44	31.13	3.00	22.00	25.00	5.75	3.00	3.50	1.75	3.00	7.19	109	-	-	-	-	-
		3	19.44	28.25	3.00	22.00	25.00	4.63	3.50	3.50	1.75	3.00	5.57	82	-	-	-	-	-
CR(N)(E) 1-13 H	1 1/2	1	20.13	31.82	3.00	22.69	25.69	5.75	3.00	3.50	1.75	3.00	7.19	110	4.80	6.22	8.34	28.59	88
		3	20.13	28.94	3.00	22.69	25.69	4.63	3.50	3.50	1.75	3.00	5.57	83	4.80	6.22	10.56	30.17	93
CR(N)(E) 1-15 H	2	1	21.57	34.13	3.00	24.13	27.13	5.75	3.00	3.50	1.75	3.00	7.19	115	4.80	6.22	8.34	30.82	94
		3	21.57	32.94	3.00	24.13	27.13	4.38	3.50	3.50	1.75	3.00	7.07	106	4.80	6.22	10.56	32.40	98
CR(N)(E) 1-17 H	2	1	23.00	35.57	3.00	25.57	28.57	5.75	3.00	3.50	1.75	3.00	7.19	117	4.80	6.22	8.34	32.25	96
		3	23.00	34.38	3.00	25.57	28.57	4.38	3.50	3.50	1.75	3.00	7.07	108	4.80	6.22	10.56	33.83	100
CR(N) 1-19 H	3	1	25.32	39.94	3.00	28.94	34.44	6.75	4.50	4.50	0.75	5.50	8.63	154	-	-	-	-	-
		3	25.32	38.57	3.00	28.94	34.44	4.32	4.50	4.50	0.75	5.50	7.00	133	-	-	-	-	-
CR(N) 1-21 H	3	1	26.75	41.38	3.00	30.32	35.82	6.75	4.50	4.50	0.75	5.50	8.63	156	-	-	-	-	-
		3	26.75	39.94	3.00	30.32	35.82	4.32	4.50	4.50	0.75	5.50	7.00	135	-	-	-	-	-
CR(N)(E) 1-23 H	3	1	28.13	42.82	3.00	31.75	37.25	6.75	4.50	4.50	0.75	5.50	8.63	158	-	-	-	-	-
		3	28.13	41.38	3.00	31.75	37.25	4.32	4.50	4.50	0.75	5.50	7.00	137	4.80	6.22	10.56	38.96	128
CR(N) 1-25 H	3	1	29.57	44.19	3.00	33.19	38.69	6.75	4.50	4.50	0.75	5.50	8.63	159	-	-	-	-	-
		3	29.57	42.82	3.00	33.19	38.69	4.32	4.50	4.50	0.75	5.50	7.00	138	-	-	-	-	-
CR(N)(E) 1-27 H	3	1	31.00	45.63	3.00	34.57	40.07	6.75	4.50	4.50	0.75	5.50	8.63	161	-	-	-	-	-
		3	31.00	44.19	3.00	34.57	40.07	4.32	4.50	4.50	0.75	5.50	7.00	140	4.80	6.22	10.56	41.83	131

Note: Terminal box is on top of ML motors (through 30 HP). Baldor motors have terminal box on the side (40 HP and larger). Reference D2 dimension.

\* Dimensions shown for three-phase MLE motors are for 460 V versions. See page 19 for 200-240 V, three-phase dimensions.

CR, CRE, CRN, CRNE 3 H GA

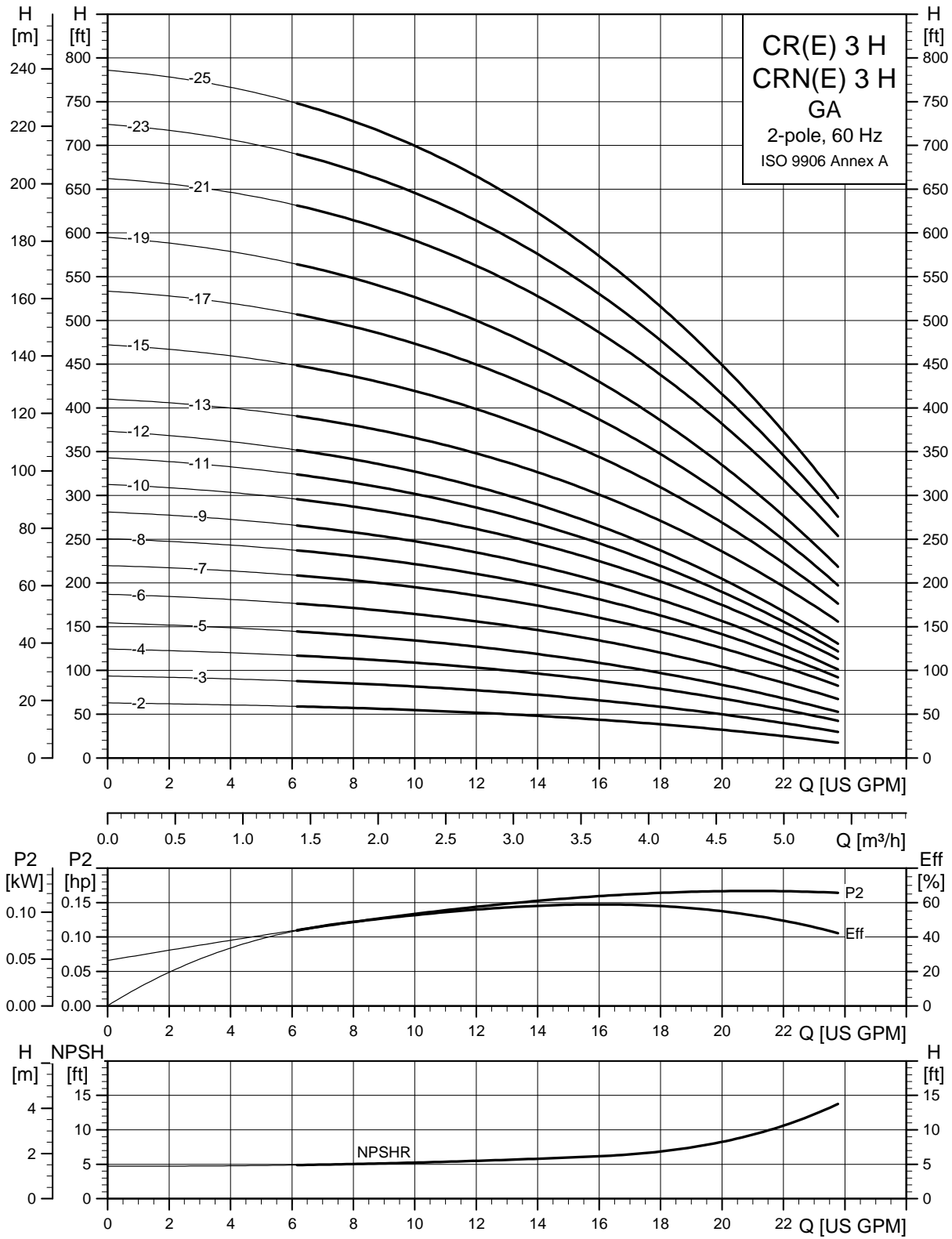

TM04 4547 0912

Dimensions and weights GA (1.5" x 1" x 6", 1.5" x 1" x 8")

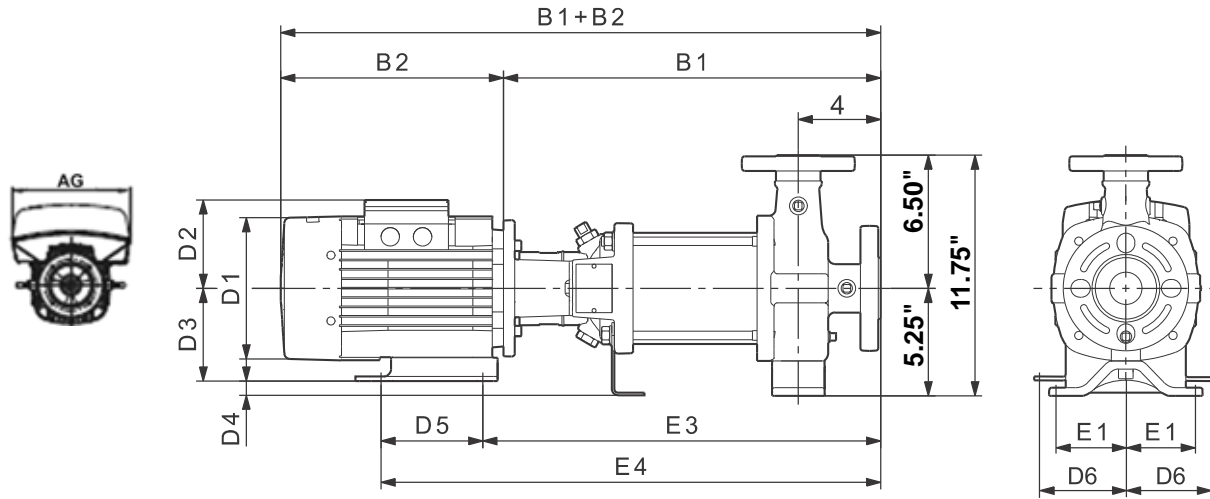

TM06 9699 1014 - TM04 4642 0310

Pump type	HP	PH	Dimensions [in] TEFC										Ship. wt. [lbs]	Dimensions [in] MLE*				Ship. wt. [lbs]	
			B1	B1+B2	E1	E3	E4	D1	D2	D3	D4	D5		D6	D1	D2	AG		B1+B2
CR(N)(E) 3-2 H	1/3	1	13.07	22.38	3.00	15.63	18.63	5.19	3.00	3.50	1.75	3.00	6.19	76	-	-	-	-	-
		3	13.07	20.69	3.00	15.63	18.63	4.63	3.50	3.50	1.75	3.00	5.57	73	-	-	-	-	-
CR(N) 3-3 H	1/2	1	13.07	22.38	3.00	15.63	18.63	5.19	3.00	3.50	1.75	3.00	6.19	77	-	-	-	-	-
		3	13.07	20.69	3.00	15.63	18.63	4.63	3.50	3.50	1.75	3.00	5.57	73	-	-	-	-	-
CR(N)(E) 3-4 H	3/4	1	13.75	23.69	3.00	16.32	19.32	5.19	3.00	3.50	1.75	3.00	6.19	84	4.80	6.22	8.34	22.21	78
		3	13.75	21.38	3.00	16.32	19.32	4.63	3.50	3.50	1.75	3.00	5.57	74	-	-	-	-	-
CR(N)(E) 3-5 H	3/4	1	14.50	24.38	3.00	17.07	20.07	5.19	3.00	3.50	1.75	3.00	6.19	85	4.80	6.22	8.34	22.96	79
		3	14.50	22.07	3.00	17.07	20.07	4.63	3.50	3.50	1.75	3.00	5.57	75	-	-	-	-	-
CR(N)(E) 3-6 H	1	1	15.19	26.38	3.00	17.75	20.75	5.75	3.00	3.50	1.75	3.00	7.19	91	4.80	6.22	8.34	23.65	80
		3	15.19	22.82	3.00	17.75	20.75	4.63	3.50	3.50	1.75	3.00	5.57	76	4.80	6.22	10.56	25.23	87
CR(N) 3-7 H	1 1/2	1	15.88	27.57	3.00	18.44	21.44	5.75	3.00	3.50	1.75	3.00	7.19	105	-	-	-	-	-
		3	15.88	24.69	3.00	18.44	21.44	4.63	3.50	3.50	1.75	3.00	5.57	78	-	-	-	-	-
CR(N)(E) 3-8 H	1 1/2	1	16.63	28.32	3.00	19.19	22.19	5.75	3.00	3.50	1.75	3.00	7.19	106	4.80	6.22	8.34	25.09	84
		3	16.63	25.38	3.00	19.19	22.19	4.63	3.50	3.50	1.75	3.00	5.57	79	4.80	6.22	10.56	26.67	89
CR(N)(E) 3-9 H	1 1/2	1	17.32	29.00	3.00	19.88	22.88	5.75	3.00	3.50	1.75	3.00	7.19	107	4.80	6.22	8.34	25.78	85
		3	17.32	26.13	3.00	19.88	22.88	4.63	3.50	3.50	1.75	3.00	5.57	80	4.80	6.22	10.56	27.36	90
CR(N) 3-10 H	2	1	18.00	30.57	3.00	20.57	23.57	5.75	3.00	3.50	1.75	3.00	7.19	111	-	-	-	-	-
		3	18.00	29.44	3.00	20.57	23.57	4.38	3.50	3.50	1.75	3.00	7.07	102	-	-	-	-	-
CR(N) 3-11 H	2	1	18.75	31.32	3.00	21.32	24.32	5.75	3.00	3.50	1.75	3.00	7.19	111	-	-	-	-	-
		3	18.75	30.13	3.00	21.32	24.32	4.38	3.50	3.50	1.75	3.00	7.07	102	-	-	-	-	-
CR(N)(E) 3-12 H	2	1	19.44	32.00	3.00	22.00	25.00	5.75	3.00	3.50	1.75	3.00	7.19	112	4.80	6.22	8.34	28.69	91
		3	19.44	30.82	3.00	22.00	25.00	4.38	3.50	3.50	1.75	3.00	7.07	103	4.80	6.22	10.56	30.27	95
CR(N) 3-13 H	3	1	21.07	35.69	3.00	24.69	30.19	6.75	4.50	4.50	0.75	5.50	8.63	139	-	-	-	-	-
		3	21.07	34.25	3.00	24.69	30.19	4.32	4.50	4.50	0.75	5.50	7.00	118	-	-	-	-	-
CR(N)(E) 3-15 H	3	1	22.44	37.13	3.00	26.07	31.57	6.75	4.50	4.50	0.75	5.50	8.63	141	-	-	-	-	-
		3	22.44	35.69	3.00	26.07	31.57	4.32	4.50	4.50	0.75	5.50	7.00	120	4.80	6.22	10.56	33.27	111
CR(N)(E) 3-17 H	3	1	23.88	38.57	3.00	27.50	33.00	6.75	4.50	4.50	0.75	5.50	8.63	152	-	-	-	-	-
		3	23.88	37.13	3.00	27.50	33.00	4.32	4.50	4.50	0.75	5.50	7.00	131	4.80	6.22	10.56	34.71	122
CR(N) 3-19 H	5	1	25.32	40.82	3.00	29.07	34.57	8.07	4.50	5.25	0.00	5.50	10.63	190	-	-	-	-	-
		3	25.32	40.82	3.00	29.07	34.57	5.25	4.50	4.50	0.75	5.50	8.69	173	-	-	-	-	-
CR(N) 3-21 H	5	1	26.75	42.25	3.00	30.50	36.00	8.07	4.50	5.25	0.00	5.50	10.63	192	-	-	-	-	-
		3	26.75	42.25	3.00	30.50	36.00	5.25	4.50	4.50	0.75	5.50	8.69	175	-	-	-	-	-
CR(N) 3-23 H	5	1	28.13	43.69	3.00	31.88	37.38	8.07	4.50	5.25	0.00	5.50	10.63	194	-	-	-	-	-
		3	28.13	43.63	3.00	31.88	37.38	5.25	4.50	4.50	0.75	5.50	8.69	176	-	-	-	-	-
CR(N)(E) 3-25 H	5	1	29.57	45.07	3.00	33.32	38.82	8.07	4.50	5.25	0.00	5.50	10.63	195	-	-	-	-	-
		3	29.57	45.07	3.00	33.32	38.82	5.25	4.50	4.50	0.75	5.50	8.69	178	7.53	7.91	11.46	42.72	152

Note: Terminal box is on top of ML motors (through 30 HP). Baldor motors have terminal box on the side (40 HP and larger). Reference D2 dimension. Weights are based on pump with TEFC motor.

\* Dimensions shown for three-phase MLE motors are for 460 V versions. See page 19 for 200-240 V, three-phase dimensions.

1) CRE 3-2 H is fitted with 1/2 HP motor.

**CR, CRE, CRN, CRNE 5 H GA**

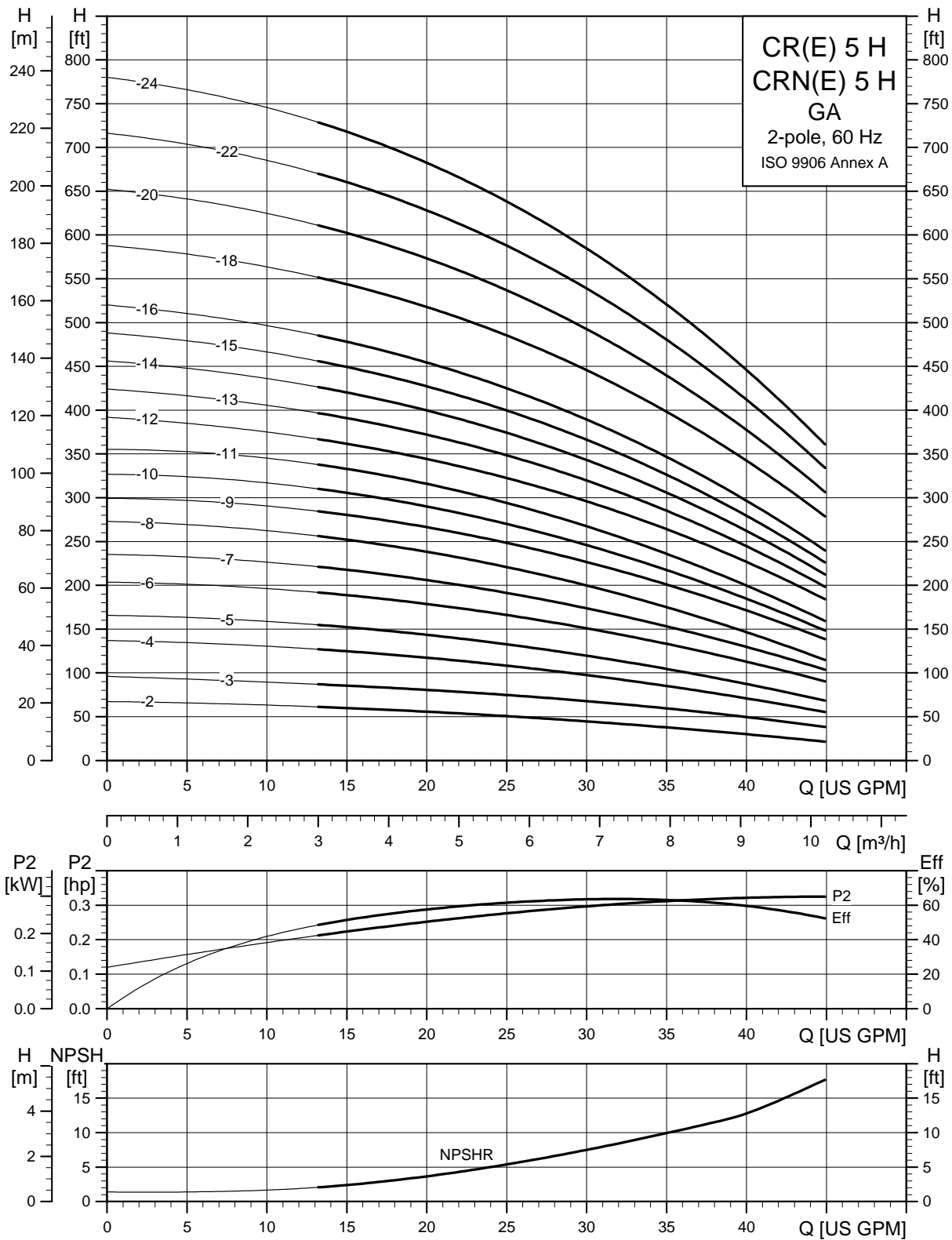

TM04 4544 0912

Dimensions and weights GA (1.5" x 1" x 6", 1.5" x 1" x 8")

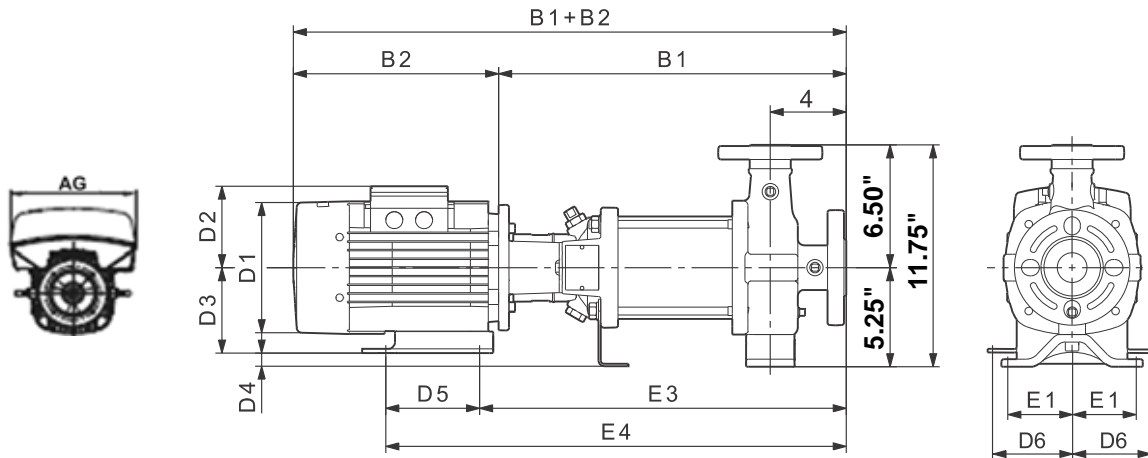

TM06 9699 1014 - TM04 4642 0310

Pump type	HP	PH	Dimensions [in] TEFC											Ship. wt. [lbs]	Dimensions [in] MLE*				Ship. wt. [lbs]
			B1	B1+B2	E1	E3	E4	D1	D2	D3	D4	D5	D6		D1	D2	AG	B1+B2	
CR(N)(E) 5-2 H	3/4	1	13.07	23.00	3.00	15.63	18.63	5.19	3.00	3.50	1.75	3.00	6.19	83	4.80	6.22	8.34	21.53	77
		3	13.07	20.69	3.00	15.63	18.63	4.63	3.50	3.50	1.75	3.00	5.57	73	-	-	-	-	-
CR(N)(E) 5-3 H	1	1	14.13	25.32	3.00	16.69	19.69	5.75	3.00	3.50	1.75	3.00	7.19	89	4.80	6.22	8.34	22.59	78
		3	14.13	21.75	3.00	16.69	19.69	4.63	3.50	3.50	1.75	3.00	5.57	74	4.80	6.22	10.56	24.17	85
CR(N)(E) 5-4 H	1 1/2	1	15.19	26.88	3.00	17.75	20.75	5.75	3.00	3.50	1.75	3.00	7.19	104	4.80	6.22	8.34	23.65	82
		3	15.19	24.00	3.00	17.75	20.75	4.63	3.50	3.50	1.75	3.00	5.57	77	4.80	6.22	10.56	25.23	87
CR(N) 5-5 H	2	1	16.25	28.82	3.00	18.82	21.82	5.75	3.00	3.50	1.75	3.00	7.19	108	-	-	-	-	-
		3	16.25	27.63	3.00	18.82	21.82	4.38	3.50	3.50	1.75	3.00	7.07	99	-	-	-	-	-
CR(N)(E) 5-6 H	2	1	17.32	29.88	3.00	19.88	22.88	5.75	3.00	3.50	1.75	3.00	7.19	109	4.80	6.22	8.34	26.57	58
		3	17.32	28.69	3.00	19.88	22.88	4.38	3.50	3.50	1.75	3.00	7.07	100	4.80	6.22	10.56	28.15	92
CR(N) 5-7 H	3	1	19.25	33.94	3.00	22.88	28.38	6.75	4.50	4.50	0.75	5.50	8.63	137	-	-	-	-	-
		3	19.25	32.50	3.00	22.88	28.38	4.32	4.50	4.50	0.75	5.50	7.00	116	-	-	-	-	-
CR(N) 5-8 H	3	1	20.32	35.00	3.00	23.94	29.44	6.75	4.50	4.50	0.75	5.50	8.63	138	-	-	-	-	-
		3	20.32	33.57	3.00	23.94	29.44	4.32	4.50	4.50	0.75	5.50	7.00	117	-	-	-	-	-
CR(N)(E) 5-9 H	3	1	21.38	36.07	3.00	25.00	30.50	6.75	4.50	4.50	0.75	5.50	8.63	139	-	-	-	-	-
		3	21.38	34.63	3.00	25.00	30.50	4.32	4.50	4.50	0.75	5.50	7.00	118	4.80	6.22	10.56	32.21	109
CR(N) 5-10 H	5	1	22.44	38.00	3.00	26.19	31.69	8.07	4.50	5.25	0.00	5.50	10.63	182	-	-	-	-	-
		3	22.44	38.00	3.00	26.19	31.69	5.25	4.50	4.50	0.75	5.50	8.69	165	-	-	-	-	-
CR(N) 5-11 H	5	1	23.50	39.07	3.00	27.25	32.75	8.07	4.50	5.25	0.00	5.50	10.63	183	-	-	-	-	-
		3	23.50	39.07	3.00	27.25	32.75	5.25	4.50	4.50	0.75	5.50	8.69	166	-	-	-	-	-
CR(N) 5-12 H	5	1	24.57	40.13	3.00	28.32	33.82	8.07	4.50	5.25	0.00	5.50	10.63	185	-	-	-	-	-
		3	24.57	40.13	3.00	28.32	33.82	5.25	4.50	4.50	0.75	5.50	8.69	168	-	-	-	-	-
CR(N)(E) 5-13 H	5	1	25.63	41.19	3.00	29.38	34.88	8.07	4.50	5.25	0.00	5.50	10.63	186	-	-	-	-	-
		3	25.63	41.19	3.00	29.38	34.88	5.25	4.50	4.50	0.75	5.50	8.69	169	7.53	7.91	11.46	38.78	143
CR(N) 5-14 H	5	1	26.75	42.25	3.00	30.50	36.00	8.07	4.50	5.25	0.00	5.50	10.63	187	-	-	-	-	-
		3	26.75	42.25	3.00	30.50	36.00	5.25	4.50	4.50	0.75	5.50	8.69	170	-	-	-	-	-
CR(N)(E) 5-15 H	5	1	27.82	43.32	3.00	31.57	37.07	8.07	4.50	5.25	0.00	5.50	10.63	189	-	-	-	-	-
		3	27.82	43.32	3.00	31.57	37.07	5.25	4.50	4.50	0.75	5.50	8.69	171	7.53	7.91	11.46	40.97	146
CR(N)(E) 5-16 H	5	1	28.88	44.38	3.00	32.63	38.13	8.07	4.50	5.25	0.00	5.50	10.63	193	-	-	-	-	-
		3	28.88	44.38	3.00	32.63	38.13	5.25	4.50	4.50	0.75	5.50	8.69	176	7.53	7.91	11.46	42.03	150
CR(N) 5-18 H	7 1/2	1	31.50	47.00	3.00	36.00	43.00	7.63	5.50	5.25	0.00	7.00	10.25	213	-	-	-	-	-
		3	31.50	47.00	3.00	36.00	43.00	5.25	5.25	5.25	0.00	7.00	8.69	192	-	-	-	-	-
CR(N)(E) 5-20 H	7 1/2	1	33.63	49.13	3.00	38.13	45.13	7.63	5.50	5.25	0.00	7.00	10.25	316	-	-	-	-	-
		3	33.63	49.13	3.00	38.13	45.13	5.25	5.25	5.25	0.00	7.00	8.69	296	7.53	7.91	11.46	48.00	286
CR(N) 5-22 H	7 1/2	1	35.75	51.25	3.00	40.25	47.25	7.63	5.50	5.25	0.00	7.00	10.25	319	-	-	-	-	-
		3	35.75	51.25	3.00	40.25	47.25	5.25	5.25	5.25	0.00	7.00	8.69	298	-	-	-	-	-
CR(N)(E) 5-24 H	7 1/2	1	37.88	53.38	3.00	42.38	49.38	7.63	5.50	5.25	0.00	7.00	10.25	321	-	-	-	-	-
		3	37.88	53.38	3.00	42.38	49.38	5.25	5.25	5.25	0.00	7.00	8.69	301	7.53	7.91	11.46	42.72	152

Note: Terminal box is on top of ML motors (through 30 HP). Baldor motors have terminal box on the side (40 HP and larger). Reference D2 dimension.

\* Dimensions shown for three-phase MLE motors are for 460 V versions. See page 19 for 200-240 V, three-phase dimensions.

CR, CRE, CRN, CRNE 10 H G22

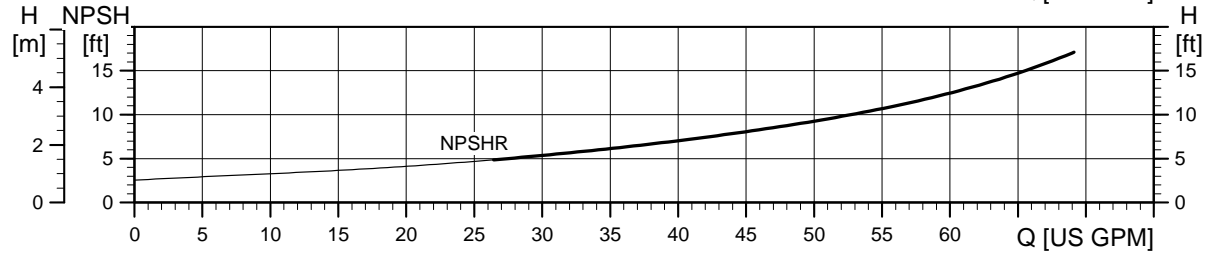
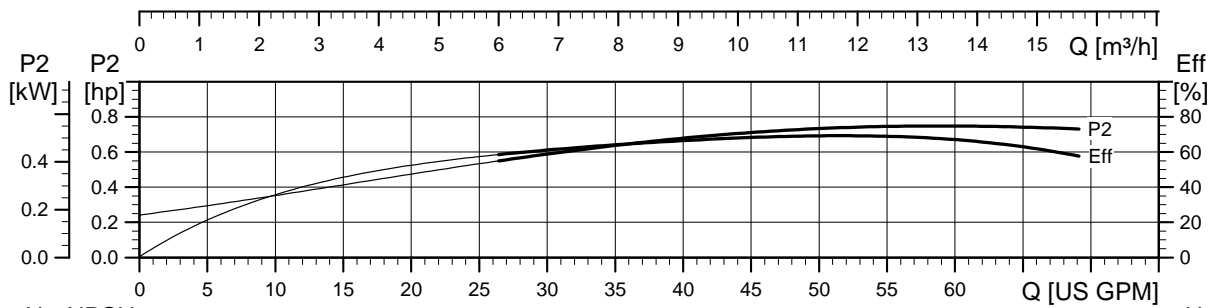
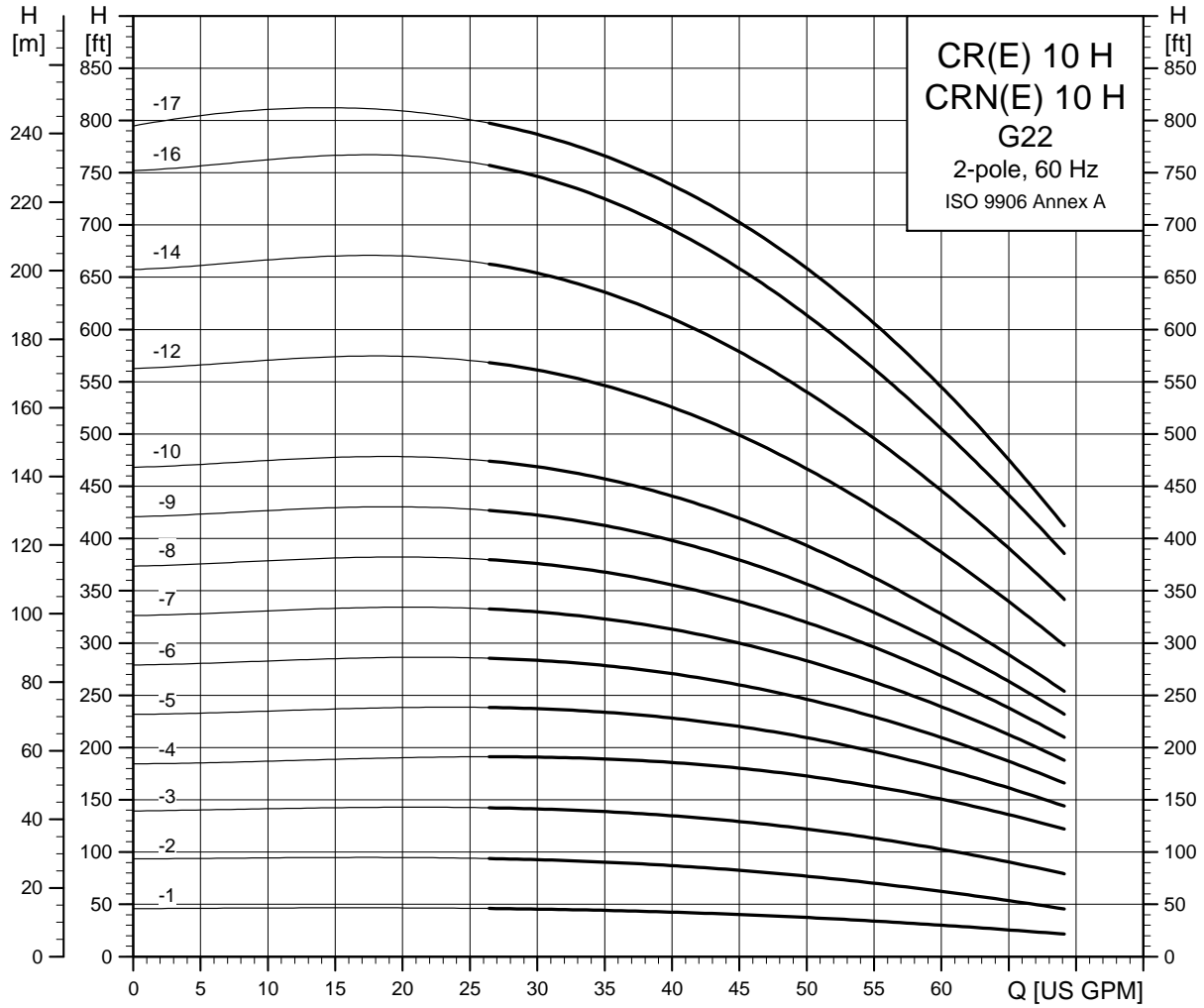

TM04 6285 0912

Dimensions and weights G22 (2" x 2")

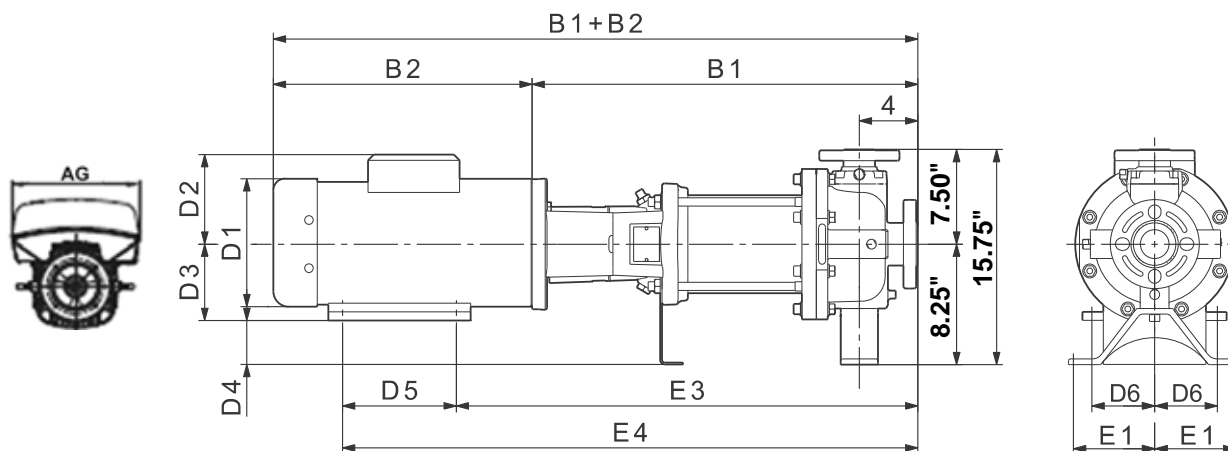

TM06 9699 1014 - TM04 4871 0310

Pump type	HP	PH	Dimensions [in] TEFC												Ship. wt. [lbs]	Dimensions [in] ODP			Dimensions [in] MLE*				Ship. wt. [lbs]
			B1	B1+B2	E1	E3	E4	D1	D2	D3	D4	D5	D6	D1		D2	B1+B2	D1	D2	AG	B1+B2		
CR(N)(E) 10-1 H	1	1	16.88	26.82	4.88	19.44	22.44	6.19	5.19	3.50	4.75	3.00	2.44	246	-	-	-	4.80	6.22	8.34	25.34	240	
		3	16.88	24.50	4.88	19.44	22.44	5.57	4.63	3.50	4.75	3.00	2.44	236	-	-	-	4.80	6.22	10.56	26.92	244	
CR(N)(E) 10-2 H	2	1	16.88	28.57	4.88	19.44	22.44	7.19	5.75	3.50	4.75	3.00	2.44	264	-	-	-	4.80	6.22	8.34	26.13	246	
		1 1/2	3	16.88	25.69	4.88	19.44	22.44	5.57	4.63	3.50	4.75	3.00	2.44	237	-	-	-	4.80	6.22	10.56	26.92	246
CR(N) 10-3 H	3	1	20.50	35.13	4.88	24.13	28.63	8.63	6.75	4.50	3.75	4.50	3.75	308	-	-	-	-	-	-	-	-	
		3	20.50	33.69	4.88	24.13	28.63	7.00	4.32	4.50	3.75	4.50	3.75	287	-	-	-	-	-	-	-	-	
CR(N)(E) 10-4 H	3	1	21.69	36.32	4.88	25.32	29.82	8.63	6.75	4.50	3.75	4.50	3.75	310	-	-	-	-	-	-	-	-	
		3	21.69	34.88	4.88	25.32	29.82	7.00	4.32	4.50	3.75	4.50	3.75	289	-	-	-	4.80	6.22	10.56	32.52	279	
CR(N) 10-5 H	5	1	22.88	38.38	4.88	26.63	31.13	10.63	8.07	5.25	3.00	4.50	3.75	348	-	-	-	-	-	-	-	-	
		3	22.88	38.38	4.88	26.63	31.13	8.69	5.25	4.50	3.75	4.50	3.75	331	-	-	-	-	-	-	-	-	
CR(N)(E) 10-6 H	5	1	24.07	39.57	4.88	27.82	32.32	10.63	8.07	5.25	3.00	4.50	3.75	350	-	-	-	-	-	-	-	-	
		3	24.07	39.57	4.88	27.82	32.32	8.69	5.25	4.50	3.75	4.50	3.75	333	-	-	-	7.53	7.91	11.46	37.22	307	
CR(N) 10-7 H	5	1	25.19	40.75	4.88	28.94	33.44	10.63	8.07	5.25	3.00	4.50	3.75	357	-	-	-	-	-	-	-	-	
		3	25.19	40.75	4.88	28.94	33.44	8.69	5.25	4.50	3.75	4.50	3.75	340	-	-	-	-	-	-	-	-	
CR(N)(E) 10-8 H	7 1/2	1	26.88	42.44	4.88	31.38	36.88	10.25	7.63	5.25	3.00	5.50	4.25	371	-	-	-	-	-	-	-	-	
		3	26.88	42.44	4.88	31.38	36.88	8.69	5.25	5.25	3.00	5.50	4.25	351	-	-	-	7.53	7.91	11.46	41.25	341	
CR(N) 10-9 H	7 1/2	1	28.07	43.63	4.88	32.57	38.07	10.25	7.63	5.25	3.00	5.50	4.25	373	-	-	-	-	-	-	-	-	
		3	28.07	43.63	4.88	32.57	38.07	8.69	5.25	5.25	3.00	5.50	4.25	353	-	-	-	-	-	-	-	-	
CR(N)(E) 10-10 H	7 1/2	1	29.25	44.82	4.88	33.75	39.25	10.25	7.63	5.25	3.00	5.50	4.25	376	-	-	-	-	-	-	-	-	
		3	29.25	44.75	4.88	33.75	39.25	8.69	5.25	5.25	3.00	5.50	4.25	355	-	-	-	7.53	7.91	11.46	43.62	346	
CR(N)(E) 10-12 H	10	1	31.63	47.69	4.88	36.13	43.13	10.25	10.32	5.25	3.00	7.00	4.25	455	-	-	-	-	-	-	-	-	
		3	31.63	46.82	4.88	36.13	43.13	10.25	6.25	5.25	3.00	7.00	4.25	403	-	-	-	10.04	9.33	13.62	46.94	372	
CR(N)(E) 10-14 H	15	3	34.69	53.19	4.88	39.69	47.94	12.38	8.00	6.25	2.00	8.25	5.00	488	10.63	8.00	52.88	10.04	9.33	13.62	50.67	442	
CR(N) 10-16 H	15	3	37.07	55.57	4.88	42.07	50.32	12.38	8.00	6.25	2.00	8.25	5.00	494	10.63	8.00	55.19	-	-	-	-	-	
CR(N)(E) 10-17 H	15	3	39.38	57.94	4.88	44.38	52.63	12.38	8.00	6.25	2.00	8.25	5.00	499	10.63	8.00	57.57	10.04	9.33	13.62	55.36	453	

Note: Terminal box is on top of ML motors (through 30 HP). Baldor motors have terminal box on the side (40 HP and larger). Reference D2 dimension. Weights are based on pump with TEFC motor.

\* Dimensions shown for three-phase MLE motors are for 460 V versions. See page 19 for 200-240 V, three-phase dimensions.

1) CR(N)E 10-1 dimensions are for 1 HP motor.

2) CR(N)(E) 10-2 with single phase motor uses a 2 HP MLE motor.

**CR, CRE, CRN, CRNE 10 H GA/G05**

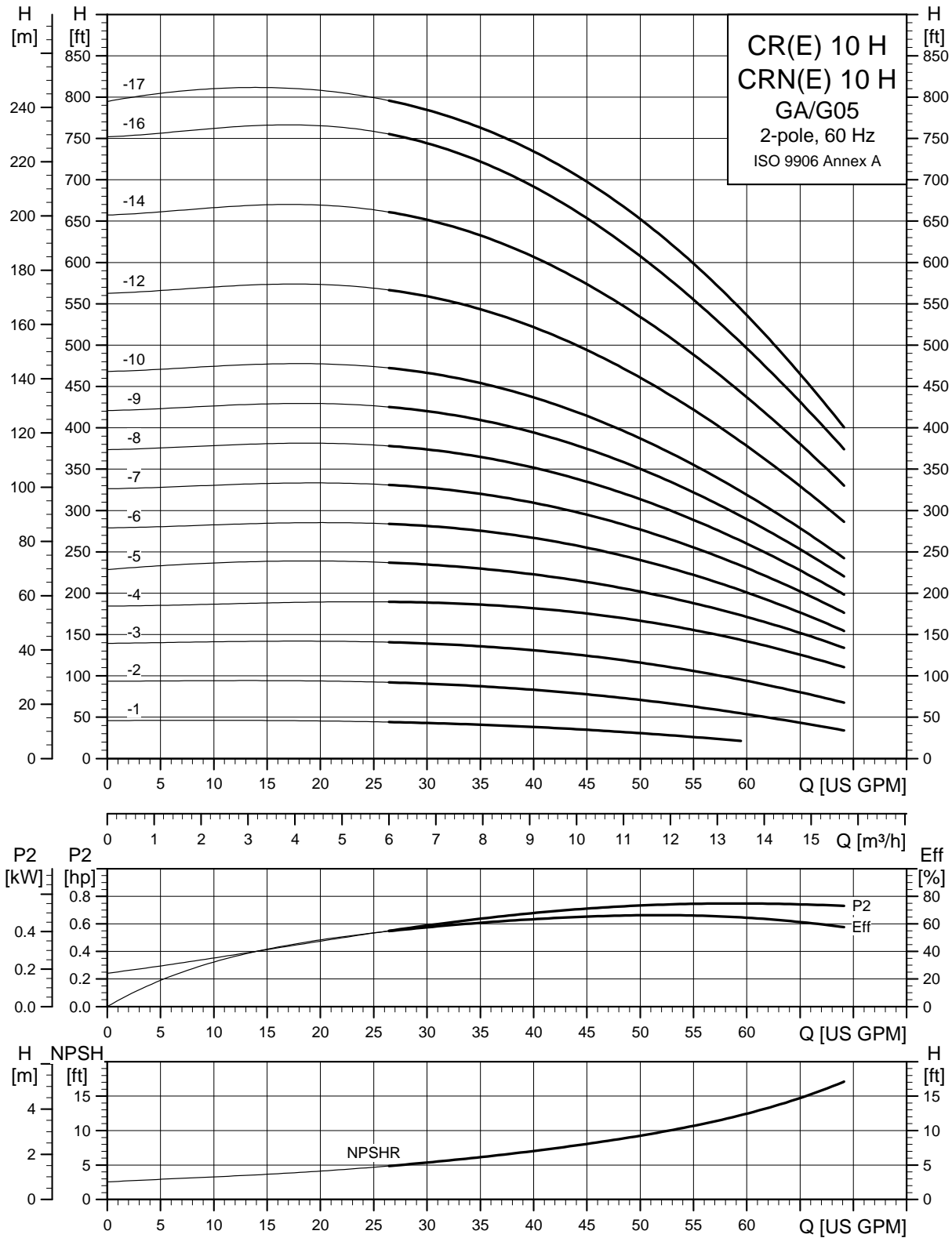

TM04 6284 0912

Dimensions and weights GA (1.5" x 1" x 6", 1.5" x 1" x 8")

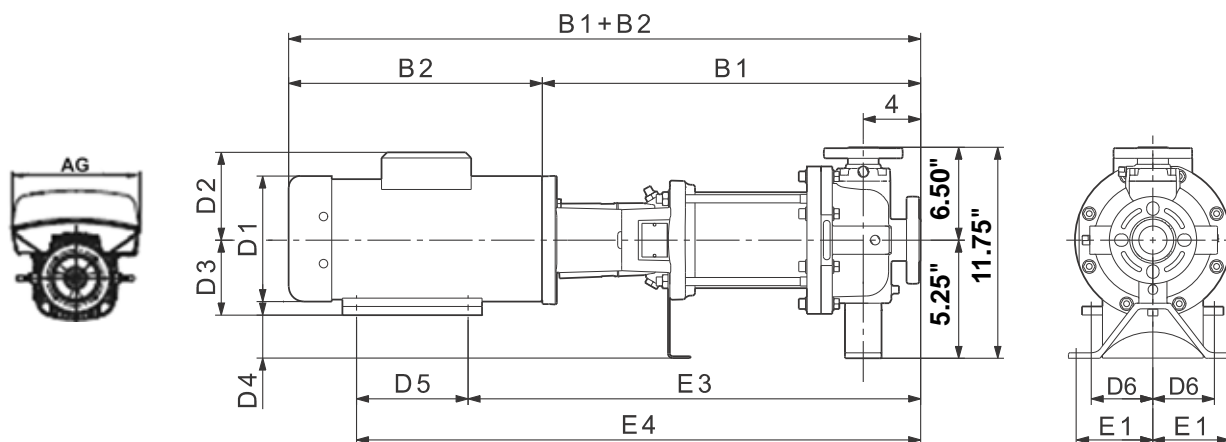

TM06 9699 1014 - TM04 4818 0310

Pump type	HP	PH	Dimensions [in] TEFC										Ship. wt. [lbs]	Dimensions [in] ODP			Dimensions [in] MLE*				Ship. wt. [lbs]		
			B1	B1+B2	E1	E3	E4	D1	D2	D3	D4	D5		D6	D1	D2	B1+B2	D1	D2	AG		B1+B2	
			CR(N)(E) 10-1 H	1	1	16.88	26.82	3.00	19.44	22.44	6.19	5.19		3.50	1.75	3.00	2.44	145	-	-		-	4.80
		3	16.88	24.50	3.00	19.44	22.44	5.57	4.63	3.50	1.75	3.00	2.44	135	-	-	-	4.80	6.22	10.56	26.92	143	
CR(N)(E) 10-2 H	2	1	16.88	28.57	3.00	19.44	22.44	7.19	5.75	3.50	1.75	3.00	2.44	163	-	-	-	4.80	6.22	8.34	26.13	144	
		1 1/2	3	16.88	25.69	3.00	19.44	22.44	5.57	4.63	3.50	1.75	3.00	2.44	136	-	-	-	4.80	6.22	10.56	26.92	145
CR(N) 10-3 H	3	1	20.50	35.13	3.00	24.13	28.63	8.63	6.75	4.50	0.75	4.50	3.75	207	-	-	-	-	-	-	-	-	
		3	20.50	33.69	3.00	24.13	28.63	7.00	4.32	4.50	0.75	4.50	3.75	186	-	-	-	-	-	-	-	-	
CR(N)(E) 10-4 H	3	1	21.69	36.32	3.00	25.32	29.82	8.63	6.75	4.50	0.75	4.50	3.75	209	-	-	-	-	-	-	-	-	
		3	21.69	34.88	3.00	25.32	29.82	7.00	4.32	4.50	0.75	4.50	3.75	188	-	-	-	4.80	6.22	10.56	32.52	178	
CR(N) 10-5 H	5	1	22.88	38.38	3.00	26.63	31.13	10.63	8.07	5.25	0.00	4.50	3.75	254	-	-	-	-	-	-	-	-	
		3	22.88	38.38	3.00	26.63	31.13	8.69	5.25	4.50	0.75	4.50	3.75	236	-	-	-	-	-	-	-	-	
CR(N)(E) 10-6 H	5	1	24.07	39.57	3.00	27.82	32.32	10.63	8.07	5.25	0.00	4.50	3.75	256	-	-	-	-	-	-	-	-	
		3	24.07	39.57	3.00	27.82	32.32	8.69	5.25	4.50	0.75	4.50	3.75	239	-	-	-	7.53	7.91	11.46	37.22	212	
CR(N) 10-7 H	5	1	25.19	40.75	3.00	28.94	33.44	10.63	8.07	5.25	0.00	4.50	3.75	260	-	-	-	-	-	-	-	-	
		3	25.19	40.75	3.00	28.94	33.44	8.69	5.25	4.50	0.75	4.50	3.75	243	-	-	-	-	-	-	-	-	
CR(N)(E) 10-8 H	7 1/2	1	26.88	42.44	3.00	31.38	36.88	10.25	7.63	5.25	0.00	5.50	4.25	274	-	-	-	-	-	-	-	-	
		3	26.88	42.44	3.00	31.38	36.88	8.69	5.25	5.25	0.00	5.50	4.25	254	-	-	-	7.53	7.91	11.46	41.25	244	
CR(N) 10-9 H	7 1/2	1	28.07	43.63	3.00	32.57	38.07	10.25	7.63	5.25	0.00	5.50	4.25	277	-	-	-	-	-	-	-	-	
		3	28.07	43.63	3.00	32.57	38.07	8.69	5.25	5.25	0.00	5.50	4.25	256	-	-	-	-	-	-	-	-	
CR(N)(E) 10-10 H	7 1/2	1	29.25	44.82	3.00	33.75	39.25	10.25	7.63	5.25	0.00	5.50	4.25	279	-	-	-	-	-	-	-	-	
		3	29.25	44.75	3.00	33.75	39.25	8.69	5.25	5.25	0.00	5.50	4.25	258	-	-	-	7.53	7.91	11.46	43.62	249	
CR(N)(E) 10-12 H	10	1	31.63	47.69	3.00	36.13	43.13	10.25	10.32	5.25	0.00	7.00	4.25	444	-	-	-	-	-	-	-	-	
		3	31.63	46.82	3.00	36.13	43.13	10.25	6.25	5.25	0.00	7.00	4.25	392	-	-	-	10.04	9.33	13.62	46.94	361	
CR(N)(E) 10-14 H	15	3	34.69	53.19	3.00	39.69	47.94	12.38	8.00	6.25	-1.00	8.25	5.00	479	10.63	8.00	52.88	10.04	9.33	13.62	50.67	434	
CR(N) 10-16 H	15	3	37.07	55.57	3.00	42.07	50.32	12.38	8.00	6.25	-1.00	8.25	5.00	483	10.63	8.00	55.19	-	-	-	-	-	
CR(N)(E) 10-17 H	15	3	39.38	57.94	3.00	44.38	52.63	12.38	8.00	6.25	-1.00	8.25	5.00	488	10.63	8.00	57.57	10.04	9.33	13.62	55.36	442	

Note: Terminal box is on top of ML motors (through 30 HP). Baldor motors have terminal box on the side (40 HP and larger). Reference D2 dimension. Weights are based on pump with TEFC motor.

\* Dimensions shown for three-phase MLE motors are for 460 V versions. See page 19 for 200-240 V, three-phase dimensions.

1) CR(N)E 10-1 dimensions are for 1 HP motor.

2) CR(N)(E) 10-2 with single phase motor uses a 2 HP MLE motor.

Dimensions and weights G05 (2" x 1" x 10")

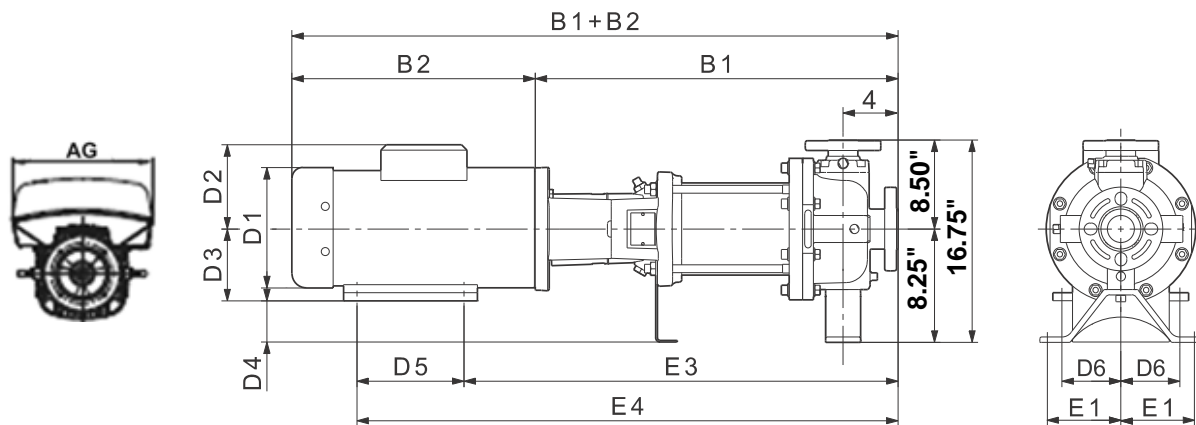

TM06 9699 1014 - TM04 4643 0310

Pump type	HP	PH	Dimensions [in] TEFC												Ship. wt. [lbs]	Dimensions [in] ODP			Dimensions [in] MLE*				Ship. wt. [lbs]
			B1	B1+B2	E1	E3	E4	D1	D2	D3	D4	D5	D6	D1		D2	B1+B2	D1	D2	AG	B1+B2		
CR(N)(E) 10-1 H	1	1	16.88	26.82	4.88	19.44	22.44	6.19	5.19	3.50	4.75	3.00	2.44	305	-	-	-	4.80	6.22	8.34	25.34	299	
		3	16.88	24.50	4.88	19.44	22.44	5.57	4.63	3.50	4.75	3.00	2.44	295	-	-	-	4.80	6.22	10.56	26.92	304	
CR(N)(E) 10-2 H	2	1	16.88	28.57	4.88	19.44	22.44	7.19	5.75	3.50	4.75	3.00	2.44	323	-	-	-	4.80	6.22	8.34	26.13	305	
		1 1/2	3	16.88	25.69	4.88	19.44	22.44	5.57	4.63	3.50	4.75	3.00	2.44	296	-	-	-	4.80	6.22	10.56	26.92	306
CR(N) 10-3 H	3	1	20.50	35.13	4.88	24.13	28.63	8.63	6.75	4.50	3.75	4.50	3.75	369	-	-	-	-	-	-	-	-	
		3	20.50	33.69	4.88	24.13	28.63	7.00	4.32	4.50	3.75	4.50	3.75	349	-	-	-	-	-	-	-	-	
CR(N)(E) 10-4 H	3	1	21.69	36.32	4.88	25.32	29.82	8.63	6.75	4.50	3.75	4.50	3.75	369	-	-	-	-	-	-	-	-	
		3	21.69	34.88	4.88	25.32	29.82	7.00	4.32	4.50	3.75	4.50	3.75	349	-	-	-	4.80	6.22	10.56	32.52	339	
CR(N) 10-5 H	5	1	22.88	38.38	4.88	26.63	31.13	10.63	8.07	5.25	3.00	4.50	3.75	410	-	-	-	-	-	-	-	-	
		3	22.88	38.38	4.88	26.63	31.13	8.69	5.25	4.50	3.75	4.50	3.75	393	-	-	-	-	-	-	-	-	
CR(N)(E) 10-6 H	5	1	24.07	39.57	4.88	27.82	32.32	10.63	8.07	5.25	3.00	4.50	3.75	410	-	-	-	-	-	-	-	-	
		3	24.07	39.57	4.88	27.82	32.32	8.69	5.25	4.50	3.75	4.50	3.75	393	-	-	-	7.53	7.91	11.46	37.22	336	
CR(N) 10-7 H	5	1	25.19	40.75	4.88	28.94	33.44	10.63	8.07	5.25	3.00	4.50	3.75	416	-	-	-	-	-	-	-	-	
		3	25.19	40.75	4.88	28.94	33.44	8.69	5.25	4.50	3.75	4.50	3.75	399	-	-	-	-	-	-	-	-	
CR(N)(E) 10-8 H	7 1/2	1	26.88	42.44	4.88	31.38	36.88	10.25	7.63	5.25	3.00	5.50	4.25	431	-	-	-	-	-	-	-	-	
		3	26.88	42.44	4.88	31.38	36.88	8.69	5.25	5.25	3.00	5.50	4.25	410	-	-	-	7.53	7.91	11.46	41.25	401	
CR(N) 10-9 H	7 1/2	1	28.07	43.63	4.88	32.57	38.07	10.25	7.63	5.25	3.00	5.50	4.25	433	-	-	-	-	-	-	-	-	
		3	28.07	43.63	4.88	32.57	38.07	8.69	5.25	5.25	3.00	5.50	4.25	412	-	-	-	-	-	-	-	-	
CR(N)(E) 10-10 H	7 1/2	1	29.25	44.82	4.88	33.75	39.25	10.25	7.63	5.25	3.00	5.50	4.25	435	-	-	-	-	-	-	-	-	
		3	29.25	44.75	4.88	33.75	39.25	8.69	5.25	5.25	3.00	5.50	4.25	415	-	-	-	7.53	7.91	11.46	43.62	405	
CR(N)(E) 10-12 H	10	1	31.63	47.69	4.88	36.13	43.13	10.25	10.32	5.25	3.00	7.00	4.25	499	-	-	-	-	-	-	-	-	
		3	31.63	46.82	4.88	36.13	43.13	10.25	6.25	5.25	3.00	7.00	4.25	447	-	-	-	10.04	9.33	13.62	46.94	416	
CR(N)(E) 10-14 H	15	3	34.69	53.19	4.88	39.69	47.94	12.38	8.00	6.25	2.00	8.25	5.00	532	10.63	8.00	52.88	10.04	9.33	13.62	50.67	486	
CR(N) 10-16 H	15	3	37.07	55.57	4.88	42.07	50.32	12.38	8.00	6.25	2.00	8.25	5.00	536	10.63	8.00	55.19	-	-	-	-	-	
CR(N)(E) 10-17 H	15	3	39.38	57.94	4.88	44.38	52.63	12.38	8.00	6.25	2.00	8.25	5.00	540	10.63	8.00	57.57	10.04	9.33	13.62	55.36	495	

Note: Terminal box is on top of ML motors (through 30 HP). Baldor motors have terminal box on the side (40 HP and larger). Reference D2 dimension. Weights are based on pump with TEFC motor.

\* Dimensions shown for three-phase MLE motors are for 460 V versions. See page 19 for 200-240 V, three-phase dimensions.

- 1) CR(N)E 10-1 dimensions are for 1 HP motor.
- 2) CR(N)(E) 10-2 with single phase motor uses a 2 HP MLE motor.

CR, CRE, CRN, CRNE 15 H G22

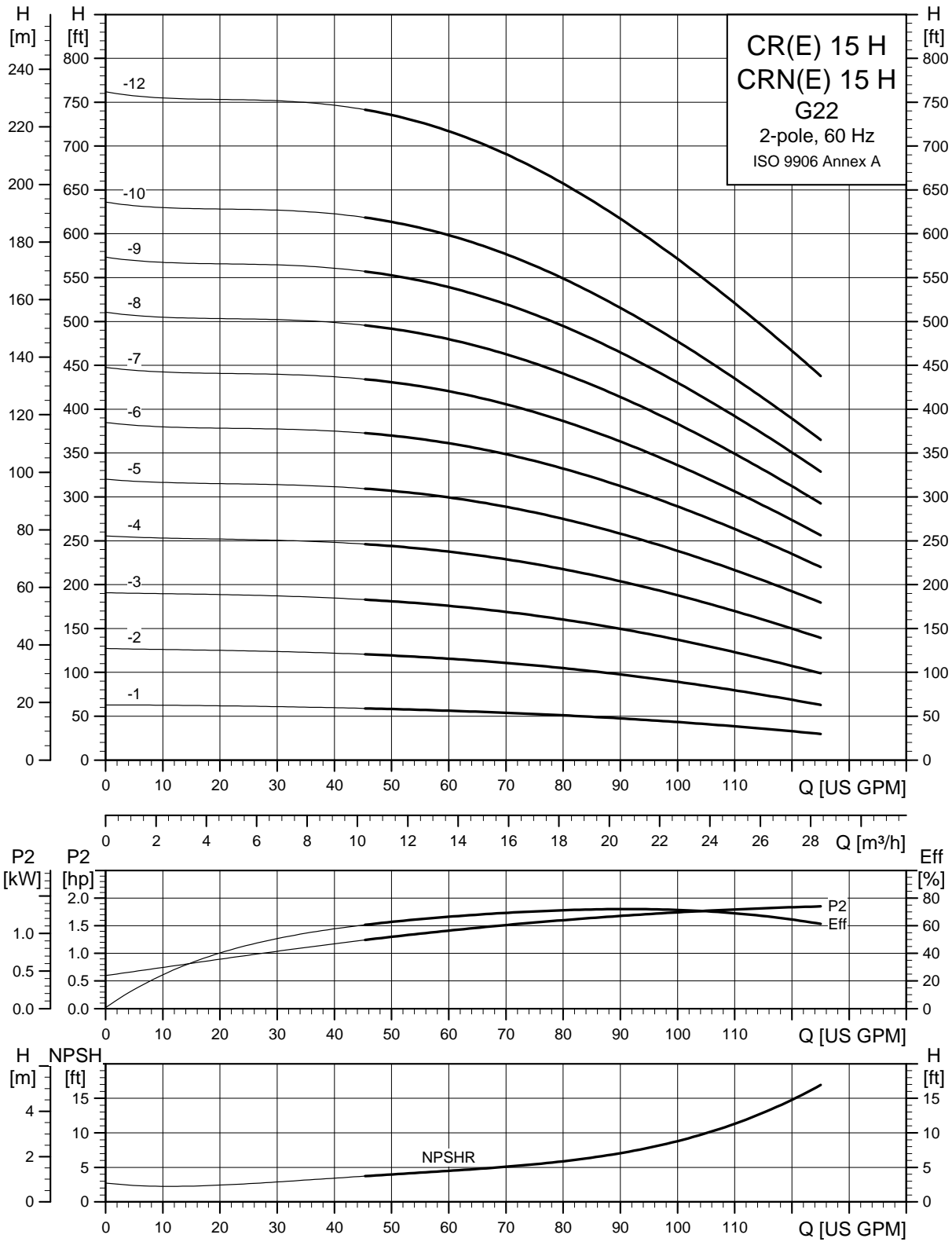

TM04-6288 0912

Dimensions and weights G22 (2" x 2")

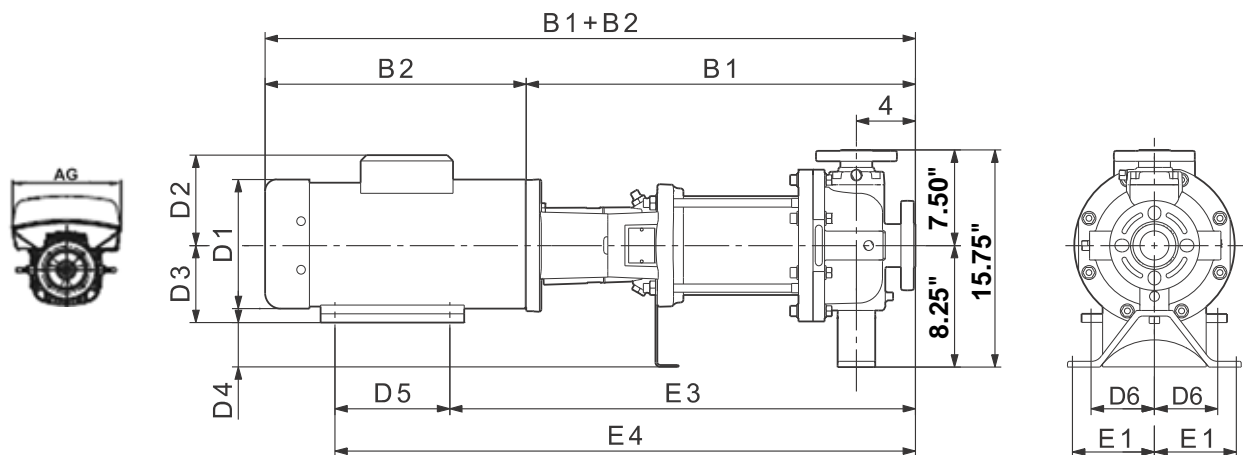

TM06 9699 1014 - TM04 4871 0310

Pump type	HP	PH	Dimensions [in] TEFC											Ship. wt. [lbs]	Dimensions [in] ODP			Dimensions [in] MLE*				Ship. wt. [lbs]
			B1	B1+B2	E1	E3	E4	D1	D2	D3	D4	D5	D6		D1	D2	B1+B2	D1	D2	AG	B1+B2	
CR(N)(E) 15-1 H	2	1	18.13	30.63	4.88	20.63	23.63	7.25	5.75	3.50	4.75	3.00	2.50	269	-	-	-	4.80	6.22	8.34	27.38	248
		3	18.13	29.50	4.88	20.63	23.63	7.13	4.38	3.50	4.75	3.00	2.50	260	-	-	-	4.80	6.22	10.56	28.96	252
CR(N)(E) 15-2 H	5	1	20.50	36.00	4.88	24.25	28.75	10.63	8.00	5.25	3.00	4.50	3.75	344	-	-	-	-	-	-	-	-
		3	20.50	36.00	4.88	24.25	28.75	8.63	5.25	4.50	3.75	4.50	3.75	327	-	-	-	7.53	7.91	11.46	33.65	300
CR(N)(E) 15-3 H	7 1/2	1	22.75	38.25	4.88	27.25	32.75	10.25	7.63	5.25	3.00	5.50	4.25	362	-	-	-	-	-	-	-	-
		3	22.75	38.25	4.88	27.25	32.75	8.63	5.25	5.25	3.00	5.50	4.25	342	-	-	-	7.53	7.91	11.46	37.12	332
CR(N)(E) 15-4 H	7 1/2	1	24.50	40.13	4.88	29.00	34.50	10.25	7.63	5.25	3.00	5.50	4.25	365	-	-	-	-	-	-	-	-
		3	24.50	40.00	4.88	29.00	34.50	8.63	5.25	5.25	3.00	5.50	4.25	344	-	-	-	7.53	7.91	11.46	38.87	335
CR(N)(E) 15-5 H	10	1	26.38	42.38	4.88	30.88	37.88	10.25	10.25	5.25	3.00	7.00	4.25	424	-	-	-	-	-	-	-	-
		3	26.38	41.50	4.88	30.88	37.88	10.25	6.25	5.25	3.00	7.00	4.25	372	-	-	-	10.04	9.33	13.62	41.69	341
CR(N)(E) 15-6 H	15	3	28.75	47.25	4.88	33.75	42.00	12.38	8.00	6.25	2.00	8.25	5.00	455	10.63	8.00	47.00	10.04	9.33	13.62	44.73	409
CR(N) 15-7 H	15	3	30.50	49.13	4.88	35.50	43.75	12.38	8.00	6.25	2.00	8.25	5.00	479	10.63	8.00	48.75	-	-	-	-	-
CR(N)(E) 15-8 H	15	3	32.25	50.88	4.88	37.25	45.50	12.38	8.00	6.25	2.00	8.25	5.00	481	10.63	8.00	50.50	10.04	9.33	13.62	48.23	436
CR(N)(E) 15-9 H	20	3	34.13	52.63	4.88	39.13	49.10	12.38	8.00	6.25	2.00	10.00	5.00	488	10.63	8.00	52.25	13.39	12.13	16.54	52.91	588
CR(N)(E) 15-10 H	20	3	35.88	54.38	4.88	40.88	50.88	12.38	8.00	6.25	2.00	10.00	5.00	484	11.50	9.00	53.75	13.39	12.13	16.54	54.66	595
CR(N)(E) 15-12 H	25	3	38.63	61.00	4.88	43.63	53.13	12.38	8.00	7.00	1.25	9.50	5.50	520	11.50	11.38	57.63	13.39	12.13	16.54	61.35	632

Note: Terminal box is on top of ML motors (through 30 HP). Baldor motors have terminal box on the side (40 HP and larger). Reference D2 dimension. Weights are based on pump with TEFC motor.

\* Dimensions shown for three-phase MLE motors are for 460 V versions. See page 19 for 200-240 V, three-phase dimensions.

**CR, CRE, CRN, CRNE 15 H GA/G05**

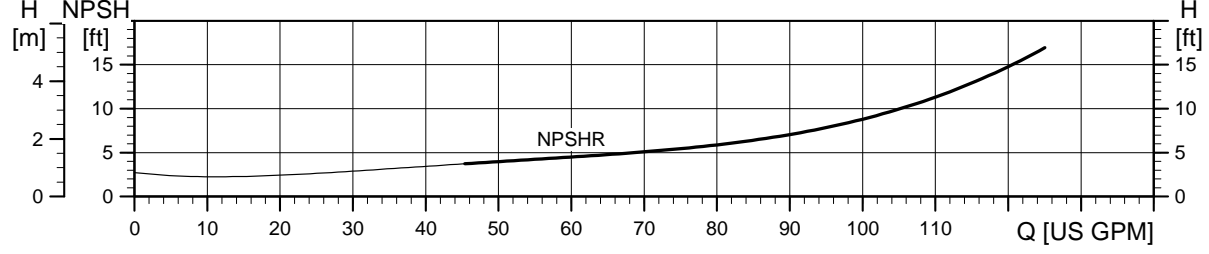
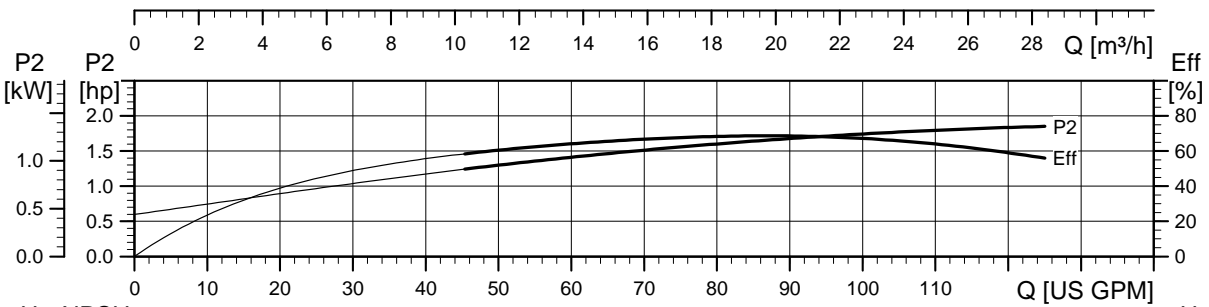
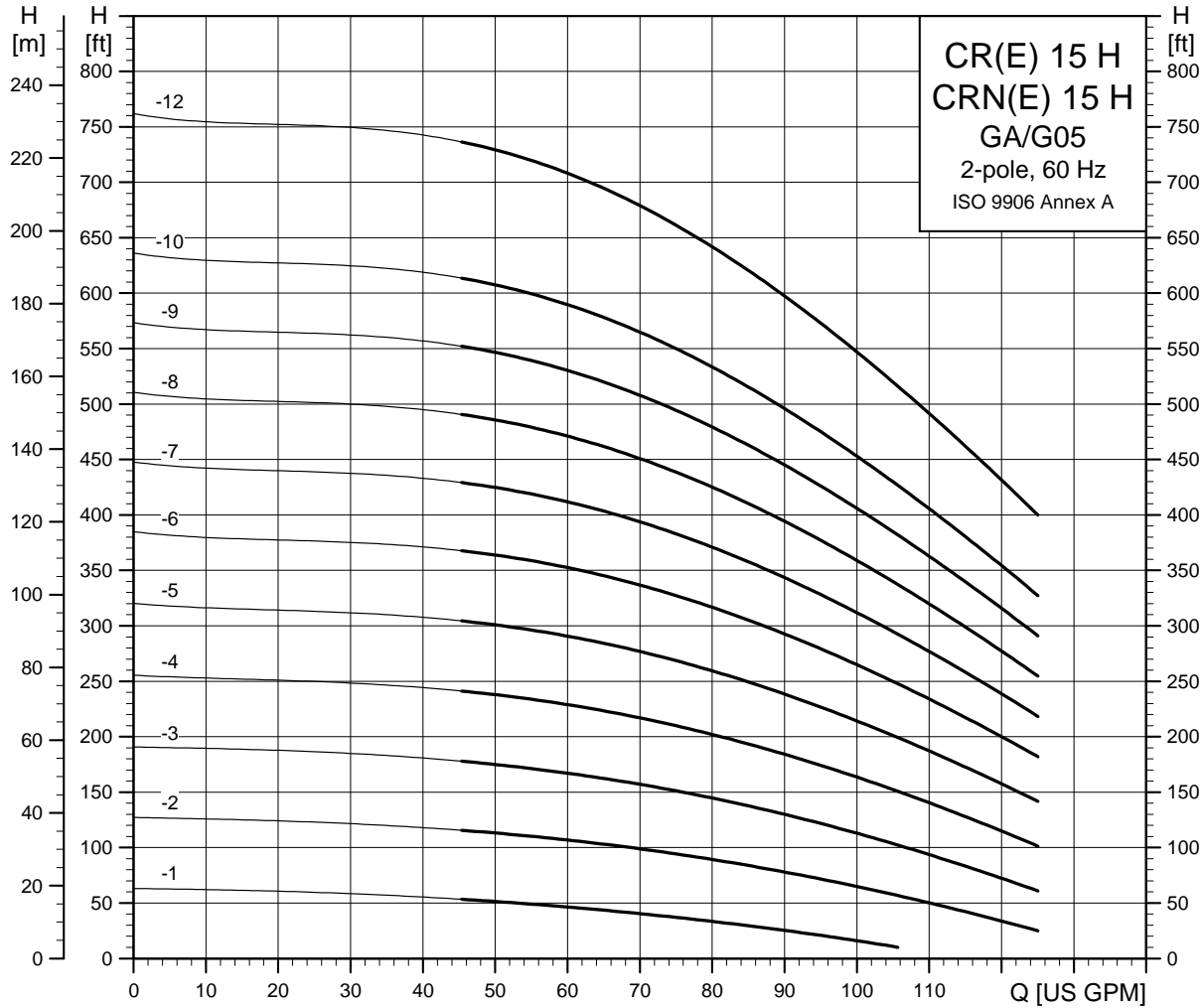

TM04 6286 0912

Dimensions and weights GA (1.5" x 1" x 6", 1.5" x 1" x 8")

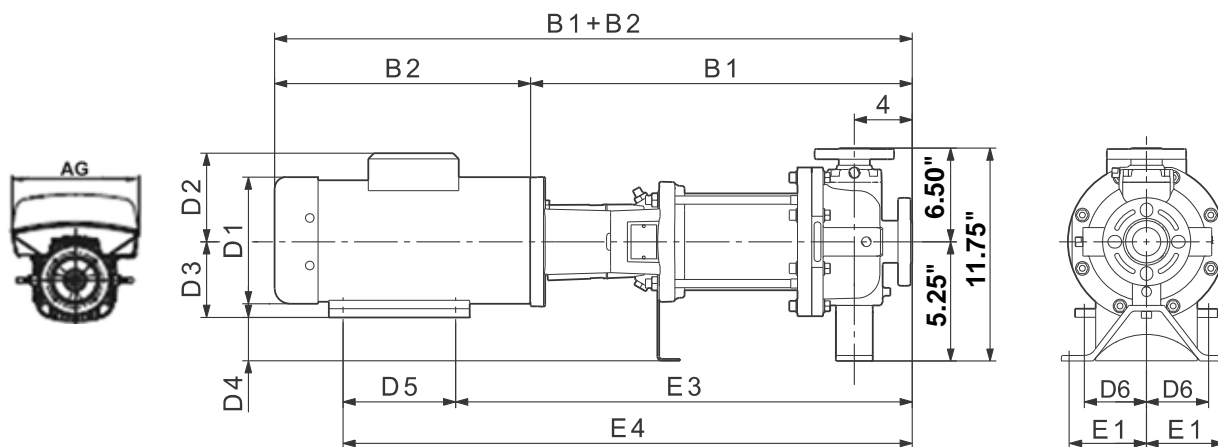

TM06 9699 1014 - TM04 4818 0310

Pump type	HP	PH	Dimensions [in] TEFC												Ship. wt. [lbs]	Dimensions [in] ODP			Dimensions [in] MLE*				Ship. wt. [lbs]
			B1	B1+B2	E1	E3	E4	D1	D2	D3	D4	D5	D6	D1		D2	B1+B2	D1	D2	AG	B1+B2		
CR(N)(E) 15-1 H	2	1	18.13	30.63	3.00	20.63	23.63	7.25	5.75	3.50	1.75	3.00	2.50	166	-	-	-	4.80	6.22	8.34	27.38	145	
		3	18.13	29.50	3.00	20.63	23.63	7.13	4.38	3.50	1.75	3.00	2.50	157	-	-	-	4.80	6.22	10.56	28.96	149	
CR(N)(E) 15-2 H	5	1	20.50	36.00	3.00	24.25	28.75	10.63	8.00	5.25	0.00	4.50	3.75	243	-	-	-	-	-	-	-	-	
		3	20.50	36.00	3.00	24.25	28.75	8.63	5.25	4.50	0.75	4.50	3.75	225	-	-	-	7.53	7.91	11.46	33.65	199	
CR(N)(E) 15-3 H	7 1/2	1	22.75	38.25	3.00	27.25	32.75	10.25	7.63	5.25	0.00	5.50	4.25	266	-	-	-	-	-	-	-	-	
		3	22.75	38.25	3.00	27.25	32.75	8.63	5.25	5.25	0.00	5.50	4.25	245	-	-	-	7.53	7.91	11.46	37.12	236	
CR(N)(E) 15-4 H	7 1/2	1	24.50	40.13	3.00	29.00	34.50	10.25	7.63	5.25	0.00	5.50	4.25	270	-	-	-	-	-	-	-	-	
		3	24.50	40.00	3.00	29.00	34.50	8.63	5.25	5.25	0.00	5.50	4.25	250	-	-	-	7.53	7.91	11.46	38.87	240	
CR(N)(E) 15-5 H	10	1	26.38	42.38	3.00	30.88	37.88	10.25	10.25	5.25	0.00	7.00	4.25	327	-	-	-	-	-	-	-	-	
		3	26.38	41.50	3.00	30.88	37.88	10.25	6.25	5.25	0.00	7.00	4.25	275	-	-	-	10.04	9.33	13.62	41.69	244	
CR(N)(E) 15-6 H	15	3	28.75	47.25	3.00	33.75	42.00	12.38	8.00	6.25	-1.00	8.25	5.00	360	10.63	8.00	47.00	10.04	9.33	13.62	44.73	315	
CR(N) 15-7 H	15	3	30.50	49.13	3.00	35.50	43.75	12.38	8.00	6.25	-1.00	8.25	5.00	367	10.63	8.00	48.75	-	-	-	-	-	
CR(N)(E) 15-8 H	15	3	32.25	50.88	3.00	37.25	45.50	12.38	8.00	6.25	-1.00	8.25	5.00	470	10.63	8.00	50.50	10.04	9.33	13.62	48.23	425	
CR(N)(E) 15-9 H	20	3	34.13	52.63	3.00	39.13	49.10	12.38	8.00	6.25	-1.00	10.00	5.00	477	10.63	8.00	52.25	13.39	12.13	16.54	52.91	577	
CR(N)(E) 15-10 H	20	3	35.88	54.38	3.00	40.88	50.88	12.38	8.00	6.25	-1.00	10.00	5.00	476	11.50	9.00	53.75	13.39	12.13	16.54	54.66	586	
CR(N)(E) 15-12 H	25	3	38.63	61.00	3.00	43.63	53.13	12.38	8.00	7.00	-1.75	9.50	5.50	509	11.50	11.38	57.63	13.39	12.13	16.54	61.35	621	

Note: Terminal box is on top of ML motors (through 30 HP). Baldor motors have terminal box on the side (40 HP and larger). Reference D2 dimension. Weights are based on pump with TEFC motor.

\* Dimensions shown for three-phase MLE motors are for 460 V versions. See page 19 for 200-240 V, three-phase dimensions.

Dimensions and weights G05 (2" x 1" x 10")

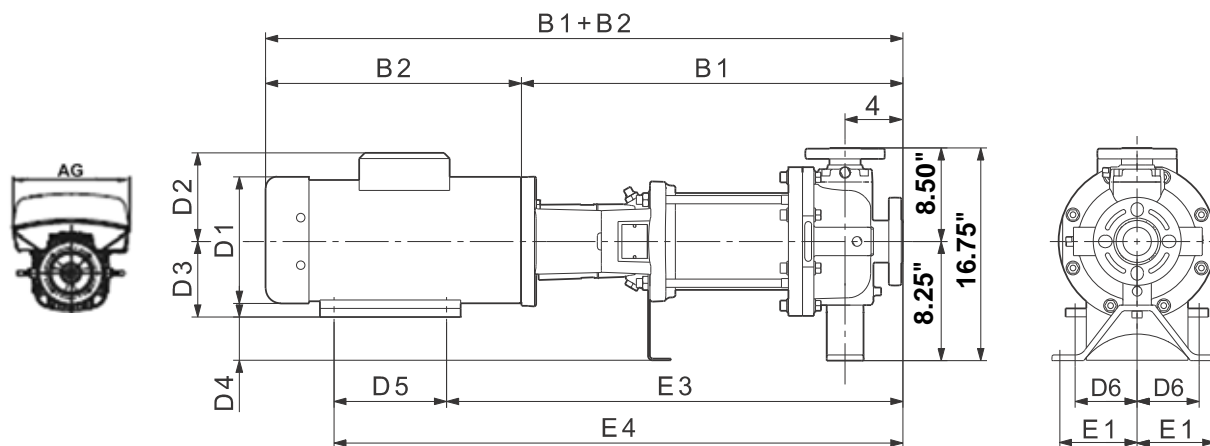

TM06 9699 1014 - TM04 4643 0310

Pump type	HP	PH	Dimensions [in] TEFC											Ship. wt. [lbs]	Dimensions [in] ODP			Dimensions [in] MLE*				Ship. wt. [lbs]
			B1	B1+B2	E1	E3	E4	D1	D2	D3	D4	D5	D6		D1	D2	B1+B2	D1	D2	AG	B1+B2	
CR(N)(E) 15-1 H	2	1	18.13	30.63	4.88	20.63	23.63	7.25	5.75	3.50	4.75	3.00	2.50	329	-	-	-	4.80	6.22	8.34	27.38	308
		3	18.13	29.50	4.88	20.63	23.63	7.13	4.38	3.50	4.75	3.00	2.50	320	-	-	-	4.80	6.22	10.56	28.96	312
CR(N)(E) 15-2 H	5	1	20.50	36.00	4.88	24.25	28.75	10.63	8.00	5.25	3.00	4.50	3.75	403	-	-	-	-	-	-	-	-
		3	20.50	36.00	4.88	24.25	28.75	8.63	5.25	4.50	3.75	4.50	3.75	386	-	-	-	7.53	7.91	11.46	33.65	359
CR(N)(E) 15-3 H	7 1/2	1	22.75	38.25	4.88	27.25	32.75	10.25	7.63	5.25	3.00	5.50	4.25	422	-	-	-	-	-	-	-	-
		3	22.75	38.25	4.88	27.25	32.75	8.63	5.25	5.25	3.00	5.50	4.25	401	-	-	-	7.53	7.91	11.46	37.12	392
CR(N)(E) 15-4 H	7 1/2	1	24.50	40.13	4.88	29.00	34.50	10.25	7.63	5.25	3.00	5.50	4.25	426	-	-	-	-	-	-	-	-
		3	24.50	40.00	4.88	29.00	34.50	8.63	5.25	5.25	3.00	5.50	4.25	406	-	-	-	7.53	7.91	11.46	38.87	396
CR(N)(E) 15-5 H	10	1	26.38	42.38	4.88	30.88	37.88	10.25	10.25	5.25	3.00	7.00	4.25	483	-	-	-	-	-	-	-	-
		3	26.38	41.50	4.88	30.88	37.88	10.25	6.25	5.25	3.00	7.00	4.25	431	-	-	-	10.04	9.33	13.62	41.69	401
CR(N)(E) 15-6 H	15	3	28.75	47.25	4.88	33.75	42.00	12.38	8.00	6.25	2.00	8.25	5.00	516	10.63	8.00	47.00	10.04	9.33	13.62	44.73	471
CR(N) 15-7 H	15	3	30.50	49.13	4.88	35.50	43.75	12.38	8.00	6.25	2.00	8.25	5.00	518	10.63	8.00	48.75	-	-	-	-	-
CR(N)(E) 15-8 H	15	3	32.25	50.88	4.88	37.25	45.50	12.38	8.00	6.25	2.00	8.25	5.00	529	10.63	8.00	50.50	10.04	9.33	13.62	48.23	484
CR(N)(E) 15-9 H	20	3	34.13	52.63	4.88	39.13	49.10	12.38	8.00	6.25	2.00	10.00	5.00	529	10.63	8.00	52.25	13.39	12.13	16.54	52.91	630
CR(N)(E) 15-10 H	20	3	35.88	54.38	4.88	40.88	50.88	12.38	8.00	6.25	2.00	10.00	5.00	528	11.50	9.00	53.75	13.39	12.13	16.54	54.66	639
CR(N)(E) 15-12 H	25	3	38.63	61.00	4.88	43.63	53.13	12.38	8.00	7.00	1.25	9.50	5.50	561	11.50	11.38	57.63	13.39	12.13	16.54	61.35	674

Note: Terminal box is on top of ML motors (through 30 HP). Baldor motors have terminal box on the side (40 HP and larger). Reference D2 dimension. Weights are based on pump with TEFC motor.

\* Dimensions shown for three-phase MLE motors are for 460 V versions. See page 19 for 200-240 V, three-phase dimensions.

**CR, CRE, CRN, CRNE 15 H GB**

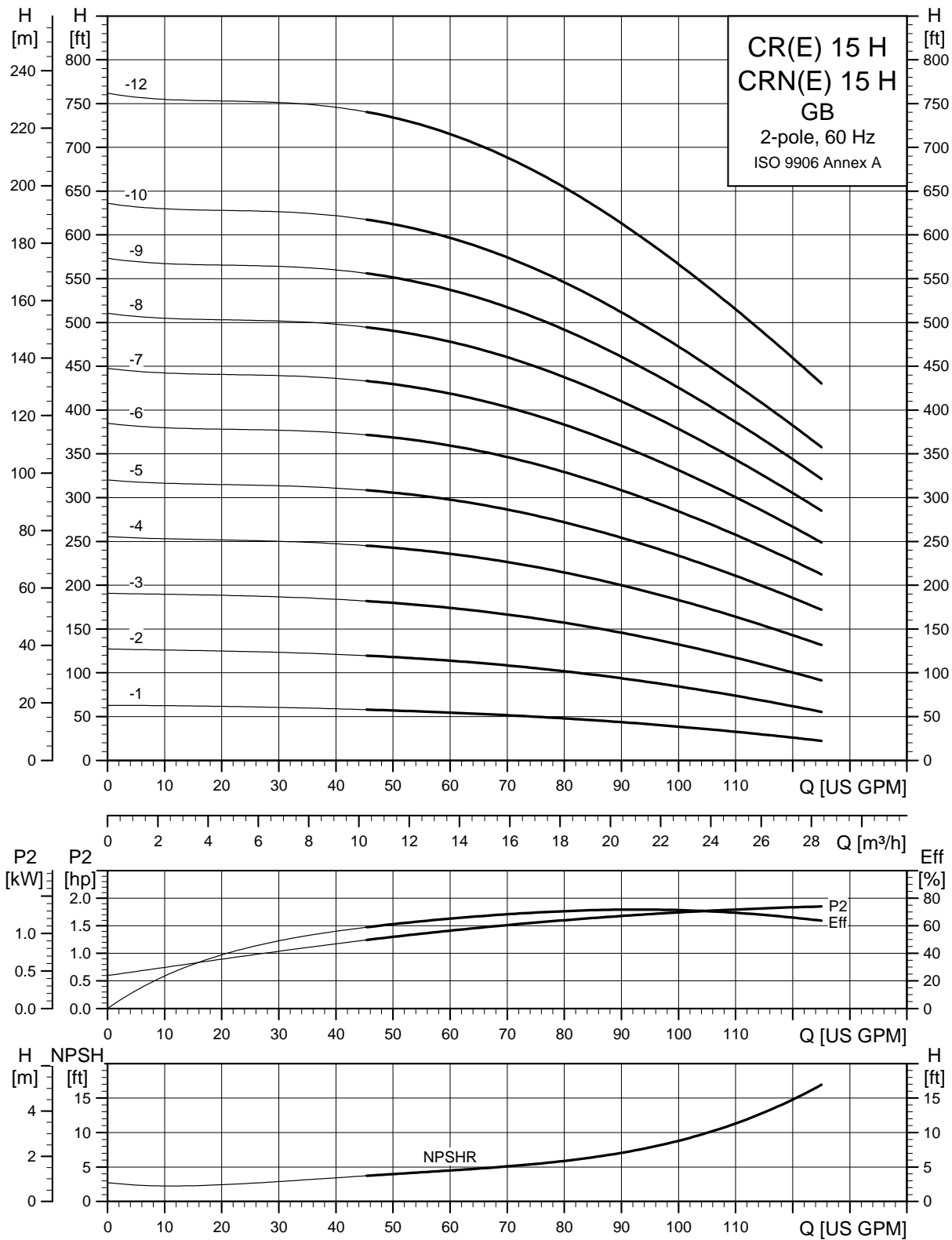

TM04 6287 0912

Dimensions and weights GB (3" x 1.5" x 6", 3" x 1.5" x 8")

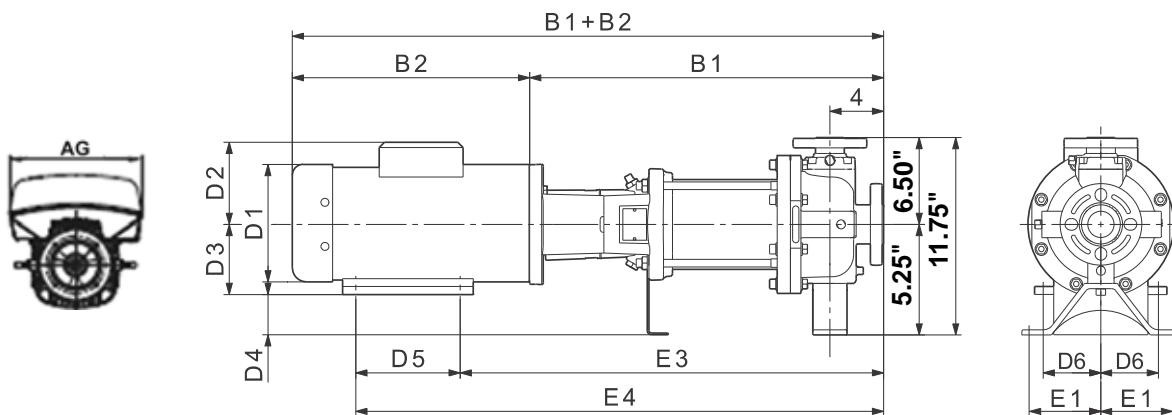

TM06 9699 1014 - TM04 4818 0310

Pump type	HP	PH	Dimensions [in] TEFC											Ship. wt. [lbs]	Dimensions [in] ODP			Dimensions [in] MLE*				Ship. wt. [lbs]
			B1	B1+B2	E1	E3	E4	D1	D2	D3	D4	D5	D6		D1	D2	B1+B2	D1	D2	AG	B1+B2	
CR(N)(E) 15-1 H	2	1	19.13	31.63	3.00	21.63	24.63	7.25	5.75	3.50	1.75	3.00	2.50	172	-	-	-	4.80	6.22	8.34	28.38	151
		3	19.13	30.50	3.00	21.63	24.63	7.13	4.38	3.50	1.75	3.00	2.50	163	-	-	-	4.80	6.22	10.56	29.96	155
CR(N)(E) 15-2 H	5	1	21.50	37.00	3.00	25.25	29.75	10.63	8.00	5.25	0.00	4.50	3.75	247	-	-	-	-	-	-	-	-
		3	21.50	37.00	3.00	25.25	29.75	8.63	5.25	4.50	0.75	4.50	3.75	230	-	-	-	7.53	7.91	11.46	34.65	203
CR(N)(E) 15-3 H	7 1/2	1	23.75	39.38	3.00	28.25	33.75	10.25	7.63	5.25	0.00	5.50	4.25	272	-	-	-	-	-	-	-	-
		3	23.75	39.25	3.00	28.25	33.75	8.63	5.25	5.25	0.00	5.50	4.25	252	-	-	-	7.53	7.91	11.46	38.12	242
CR(N)(E) 15-4 H	7 1/2	1	25.63	41.13	3.00	30.13	35.63	10.25	7.63	5.25	0.00	5.50	4.25	274	-	-	-	-	-	-	-	-
		3	25.63	41.13	3.00	30.13	35.63	8.63	5.25	5.25	0.00	5.50	4.25	254	-	-	-	7.53	7.91	11.46	40.00	244
CR(N)(E) 15-5 H	10	1	27.38	43.38	3.00	31.88	38.88	10.25	10.25	5.25	0.00	7.00	4.25	334	-	-	-	-	-	-	-	-
		3	27.38	42.50	3.00	31.88	38.88	10.25	6.25	5.25	0.00	7.00	4.25	282	-	-	-	10.04	9.33	13.62	42.69	251
CR(N)(E) 15-6 H	15	3	29.75	48.38	3.00	34.75	43.00	12.38	8.00	6.25	-1.00	8.25	5.00	367	10.63	8.00	48.00	10.04	9.33	13.62	45.73	321
CR(N) 15-7 H	15	3	31.50	50.13	3.00	36.50	44.75	12.38	8.00	6.25	-1.00	8.25	5.00	468	10.63	8.00	49.75	-	-	-	-	-
CR(N)(E) 15-8 H	15	3	33.38	51.88	3.00	38.38	46.63	12.38	8.00	6.25	-1.00	8.25	5.00	477	10.63	8.00	51.50	10.04	9.33	13.62	49.36	431
CR(N)(E) 15-9 H	20	3	35.13	53.63	3.00	40.13	50.10	12.38	8.00	6.25	-1.00	10.00	5.00	483	10.63	8.00	53.25	13.39	12.13	16.54	53.91	584
CR(N)(E) 15-10 H	20	3	36.88	55.38	3.00	41.88	51.88	12.38	8.00	6.25	-1.00	10.00	5.00	482	11.50	9.00	54.88	13.39	12.13	16.54	55.66	592
CR(N)(E) 15-12 H	25	3	39.63	62.00	3.00	44.63	54.13	12.38	8.00	7.00	-1.75	9.50	5.50	513	11.50	11.38	58.63	13.39	12.13	16.54	62.35	626

Note: Terminal box is on top of ML motors (through 30 HP). Baldor motors have terminal box on the side (40 HP and larger). Reference D2 dimension. Weights are based on pump with TEFC motor.

\* Dimensions shown for three-phase MLE motors are for 460 V versions. See page 19 for 200-240 V, three-phase dimensions.

CR, CRE, CRN, CRNE 20 H G22

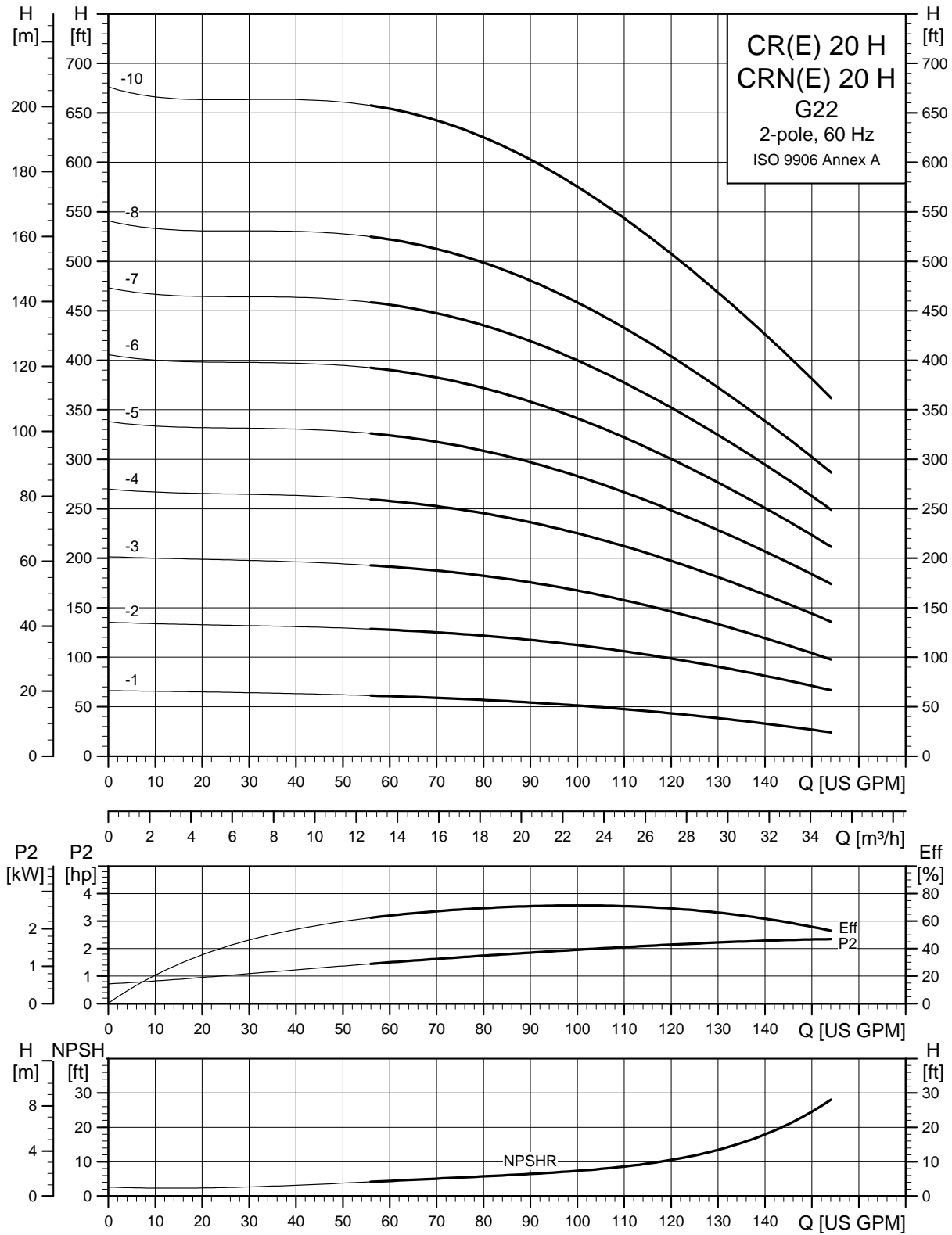

TM04 6291 0912

Dimensions and weights G22 (2" x 2")

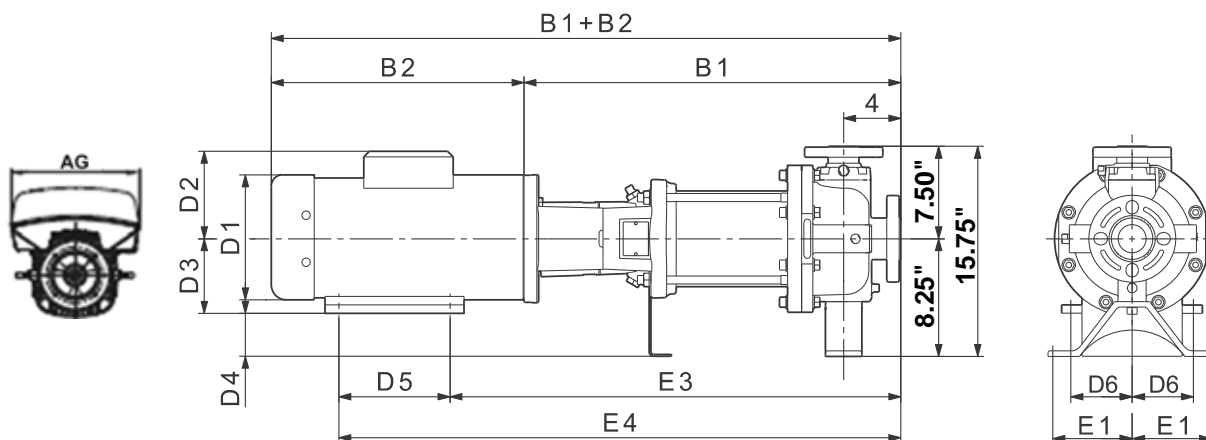

TM06 9699 1014 - TM04 4871 0310

Pump type	HP	PH	Dimensions [in] TEFC										Ship. wt. [lbs]	Dimensions [in] ODP			Dimensions [in] MLE*				Ship. wt. [lbs]	
			B1	B1+B2	E1	E3	E4	D1	D2	D3	D4	D5		D6	D1	D2	B1+B2	D1	D2	AG		B1+B2
CR(N)(E) 20-1 H	3	1	20.50	35.13	4.88	24.13	28.63	8.63	6.75	4.50	3.75	4.50	3.75	308	-	-	-	-	-	-	-	-
		3	20.50	33.75	4.88	24.13	28.63	7.00	4.38	4.50	3.75	4.50	3.75	155	-	-	-	4.80	6.22	10.56	31.33	151
CR(N)(E) 20-2 H	5	1	20.50	36.00	4.88	24.25	28.75	10.63	8.00	5.25	3.00	4.50	3.75	206	-	-	-	-	-	-	-	-
		3	20.50	36.00	4.88	24.25	28.75	8.63	5.25	4.50	3.75	4.50	3.75	175	-	-	-	7.53	7.91	11.46	33.65	300
CR(N)(E) 20-3 H	7 1/2	1	22.75	38.25	4.88	27.25	32.75	10.25	7.63	5.25	3.00	5.50	4.25	227	-	-	-	-	-	-	-	-
		3	22.75	38.25	4.88	27.25	32.75	8.63	5.25	5.25	3.00	5.50	4.25	199	-	-	-	7.53	7.91	11.46	37.12	332
CR(N)(E) 20-4 H	10	1	24.50	40.63	4.88	29.00	36.00	10.25	10.25	5.25	3.00	7.00	4.25	355	-	-	-	-	-	-	-	-
		3	24.50	39.75	4.88	29.00	36.00	10.25	6.25	5.25	3.00	7.00	4.25	232	-	-	-	10.04	9.33	13.62	39.81	337
CR(N) 20-5 H	15	3	27.00	45.50	4.88	32.00	40.25	12.38	8.00	6.25	2.00	8.25	5.00	371	10.63	8.00	45.13	10.04	9.33	13.62	42.98	407
CR(N) 20-6 H	15	3	28.75	47.25	4.88	33.75	42.00	12.38	8.00	6.25	2.00	8.25	5.00	375	10.63	8.00	47.00	10.04	9.33	13.62	44.73	409
CR(N) 20-7 H	20	3	30.50	49.13	4.88	35.50	45.50	12.38	8.00	6.25	2.00	10.00	5.00	393	11.50	9.00	48.50	13.39	12.13	16.54	49.28	584
CR(N) 20-8 H	20	3	32.25	50.88	4.88	37.25	47.25	12.38	8.00	6.25	2.00	10.00	5.00	402	11.50	9.00	50.25	13.39	12.13	16.54	51.03	588
CR(N) 20-10 H	25	3	35.00	57.38	4.88	40.00	49.50	12.38	8.00	7.00	1.25	9.50	5.50	490	11.50	11.38	54.13	13.39	12.13	16.54	57.72	626

Note: Terminal box is on top of ML motors (through 30 HP). Baldor motors have terminal box on the side (40 HP and larger). Reference D2 dimension. Weights are based on pump with TEFC motor.

\* Dimensions shown for three-phase MLE motors are for 460 V versions. See page 19 for 200-240 V, three-phase dimensions.

**CR, CRE, CRN, CRNE 20 H GA/G05**

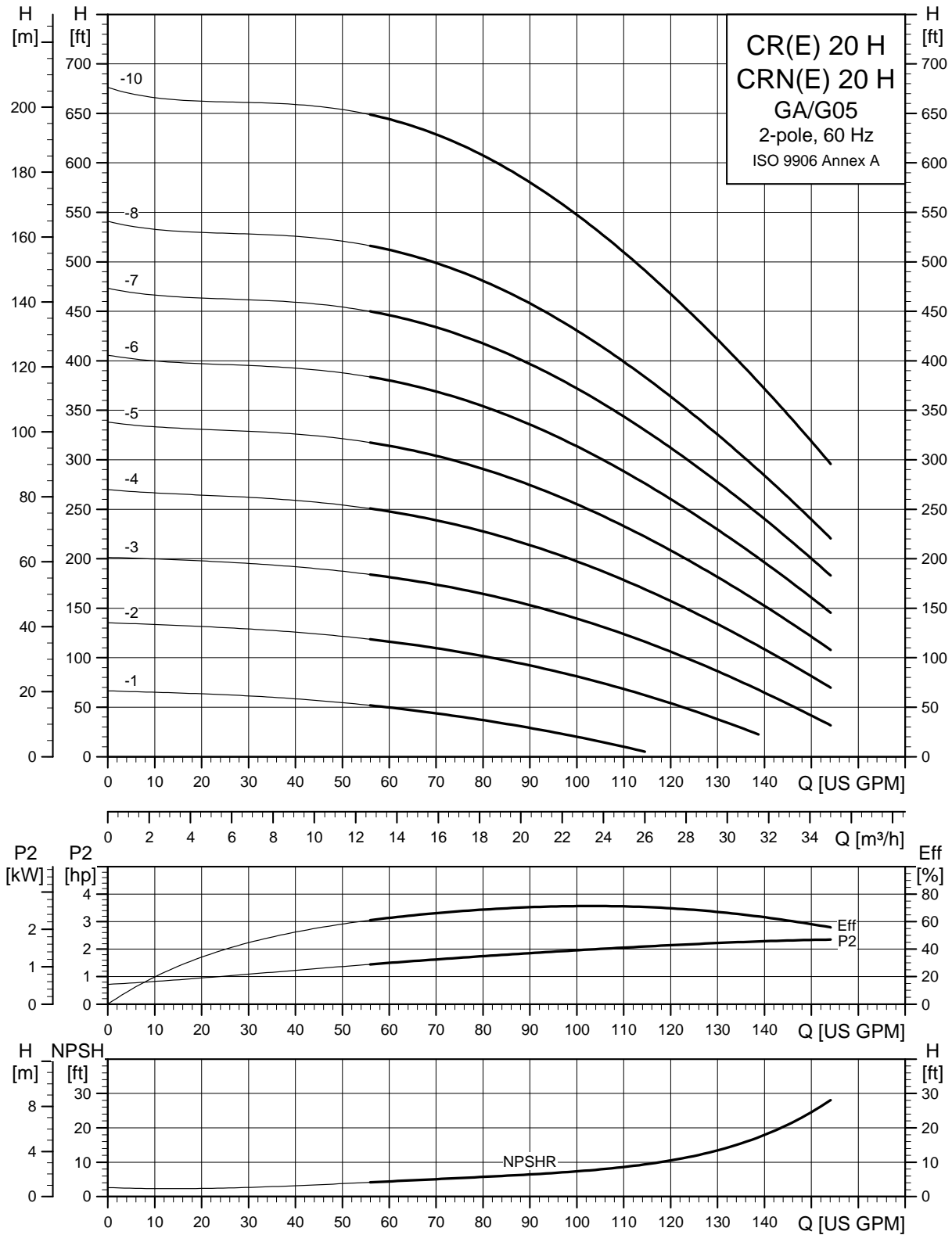

TM04 6289 0912

Dimensions and weights GA (1.5" x 1" x 6", 1.5" x 1" x 8")

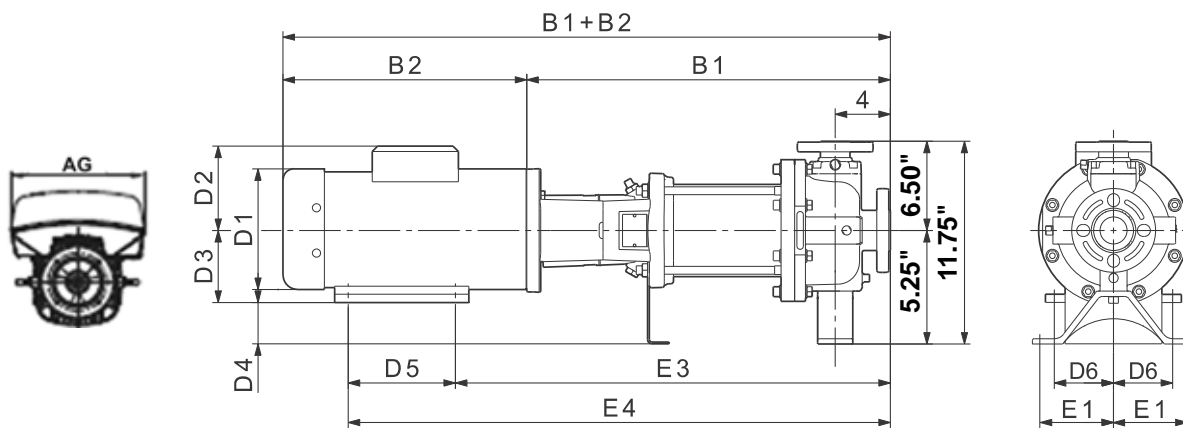

TM06 9699 1014 - TM04 4818 0310

Pump type	HP	PH	Dimensions [in] TEFC											Ship. wt. [lbs]	Dimensions [in] ODP			Dimensions [in] MLE*				Ship. wt. [lbs]
			B1	B1+B2	E1	E3	E4	D1	D2	D3	D4	D5	D6		D1	D2	B1+B2	D1	D2	AG	B1+B2	
CR(N)(E) 20-1 H	3	1	20.50	35.13	3.00	24.13	28.63	8.63	6.75	4.50	0.75	4.50	3.75	181	-	-	-	-	-	-	-	-
		3	20.50	33.75	3.00	24.13	28.63	7.00	4.38	4.50	0.75	4.50	3.75	155	-	-	-	4.80	6.22	10.56	31.33	175
CR(N)(E) 20-2 H	5	1	20.50	36.00	3.00	24.25	28.75	10.63	8.00	5.25	0.00	4.50	3.75	206	-	-	-	-	-	-	-	-
		3	20.50	36.00	3.00	24.25	28.75	8.63	5.25	4.50	0.75	4.50	3.75	175	-	-	-	7.53	7.91	11.46	33.65	199
CR(N)(E) 20-3 H	7 1/2	1	22.75	38.25	3.00	27.25	32.75	10.25	7.63	5.25	0.00	5.50	4.25	227	-	-	-	-	-	-	-	-
		3	22.75	38.25	3.00	27.25	32.75	8.63	5.25	5.25	0.00	5.50	4.25	199	-	-	-	7.53	7.91	11.46	37.12	236
CR(N)(E) 20-4 H	10	1	24.50	40.63	3.00	29.00	36.00	10.25	10.25	5.25	0.00	7.00	4.25	355	-	-	-	-	-	-	-	-
		3	24.50	39.75	3.00	29.00	36.00	10.25	6.25	5.25	0.00	7.00	4.25	232	-	-	-	10.04	9.33	13.62	39.81	242
CR(N) 20-5 H	15	3	27.00	45.50	3.00	32.00	40.25	12.38	8.00	6.25	-1.00	8.25	5.00	371	10.63	8.00	45.13	10.04	9.33	13.62	42.98	310
CR(N) 20-6 H	15	3	28.75	47.25	3.00	33.75	42.00	12.38	8.00	6.25	-1.00	8.25	5.00	375	10.63	8.00	47.00	10.04	9.33	13.62	44.73	315
CR(N) 20-7 H	20	3	30.50	49.13	3.00	35.50	45.50	12.38	8.00	6.25	-1.00	10.00	5.00	393	11.50	9.00	48.50	13.39	12.13	16.54	49.28	584
CR(N) 20-8 H	20	3	32.25	50.88	3.00	37.25	47.25	12.38	8.00	6.25	-1.00	10.00	5.00	402	11.50	9.00	50.25	13.39	12.13	16.54	51.03	588
CR(N) 20-10 H	25	3	35.00	57.38	3.00	40.00	49.50	12.38	8.00	7.00	-1.75	9.50	5.50	490	11.50	11.38	54.13	13.39	12.13	16.54	57.72	626

Note: Terminal box is on top of ML motors (through 30 HP). Baldor motors have terminal box on the side (40 HP and larger). Reference D2 dimension. Weights are based on pump with TEFC motor.

\* Dimensions shown for three-phase MLE motors are for 460 V versions. See page 19 for 200-240 V, three-phase dimensions.

Dimensions and weights G05 (2" x 1" x 10")

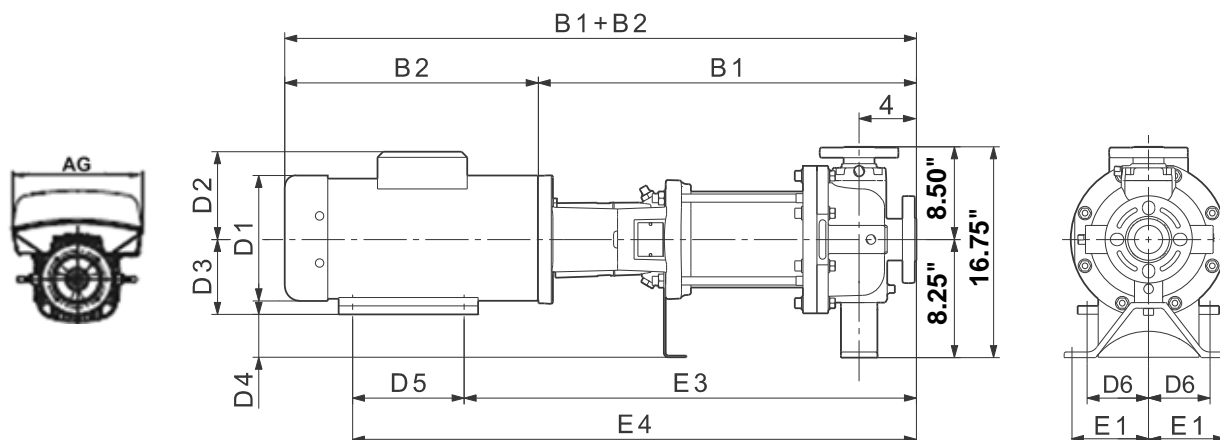

TM06 9699 1014 - TM04 4643 0310

Pump type	HP	PH	Dimensions [in] TEFC										Ship. wt. [lbs]	Dimensions [in] ODP			Dimensions [in] MLE*			Ship. wt. [lbs]		
			B1	B1+B2	E1	E3	E4	D1	D2	D3	D4	D5		D6	D1	D2	B1+B2	D1	D2		AG	B1+B2
CR(N)(E) 20-1 H	3	1	20.50	35.13	4.88	24.13	28.63	8.63	6.75	4.50	3.75	4.50	3.75	181	-	-	-	-	-	-	-	-
		3	20.50	33.75	4.88	24.13	28.63	7.00	4.38	4.50	3.75	4.50	3.75	155	-	-	-	4.80	6.22	10.56	31.33	336
CR(N)(E) 20-2 H	5	1	20.50	36.00	4.88	24.25	28.75	10.63	8.00	5.25	3.00	4.50	3.75	206	-	-	-	-	-	-	-	-
		3	20.50	36.00	4.88	24.25	28.75	8.63	5.25	4.50	3.75	4.50	3.75	175	-	-	-	7.53	7.91	11.46	33.65	359
CR(N)(E) 20-3 H	7 1/2	1	22.75	38.25	4.88	27.25	32.75	10.25	7.63	5.25	3.00	5.50	4.25	227	-	-	-	-	-	-	-	-
		3	22.75	38.25	4.88	27.25	32.75	8.63	5.25	5.25	3.00	5.50	4.25	199	-	-	-	7.53	7.91	11.46	37.12	392
CR(N)(E) 20-4 H	10	1	24.50	40.63	4.88	29.00	36.00	10.25	10.25	5.25	3.00	7.00	4.25	355	-	-	-	-	-	-	-	-
		3	24.50	39.75	4.88	29.00	36.00	10.25	6.25	5.25	3.00	7.00	4.25	232	-	-	-	10.04	9.33	13.62	39.81	398
CR(N) 20-5 H	15	3	27.00	45.50	4.88	32.00	40.25	12.38	8.00	6.25	2.00	8.25	5.00	371	10.63	8.00	45.13	10.04	9.33	13.62	42.98	467
CR(N) 20-6 H	15	3	28.75	47.25	4.88	33.75	42.00	12.38	8.00	6.25	2.00	8.25	5.00	375	10.63	8.00	47.00	10.04	9.33	13.62	44.73	471
CR(N) 20-7 H	20	3	30.50	49.13	4.88	35.50	45.50	12.38	8.00	6.25	2.00	10.00	5.00	393	11.50	9.00	48.50	13.39	12.13	16.54	49.28	584
CR(N) 20-8 H	20	3	32.25	50.88	4.88	37.25	47.25	12.38	8.00	6.25	2.00	10.00	5.00	402	11.50	9.00	50.25	13.39	12.13	16.54	51.03	588
CR(N) 20-10 H	25	3	35.00	57.38	4.88	40.00	49.50	12.38	8.00	7.00	1.25	9.50	5.50	490	11.50	11.38	54.13	13.39	12.13	16.54	57.72	626

Note: Terminal box is on top of ML motors (through 30 HP). Baldor motors have terminal box on the side (40 Hp and larger). Reference D2 dimension. Weights are based on pump with TEFC motor.

\* Dimensions shown for three-phase MLE motors are for 460 V versions. See page 19 for 200-240 V, three-phase dimensions.

**CR, CRE, CRN, CRNE 20 H GB**

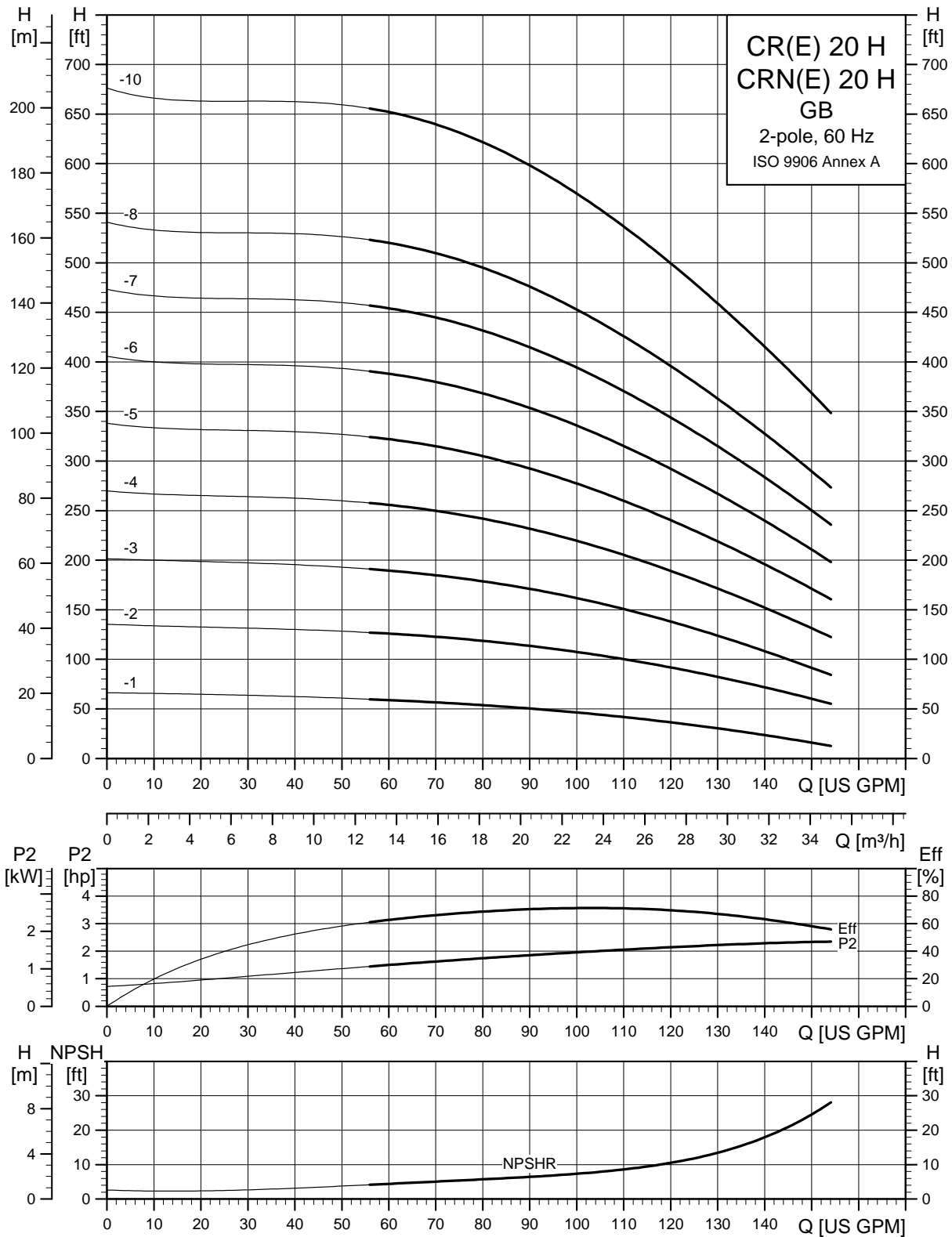

TM04 6290 09/12

Dimensions and weights GB (3" x 1.5" x 6", 3" x 1.5" x 8")

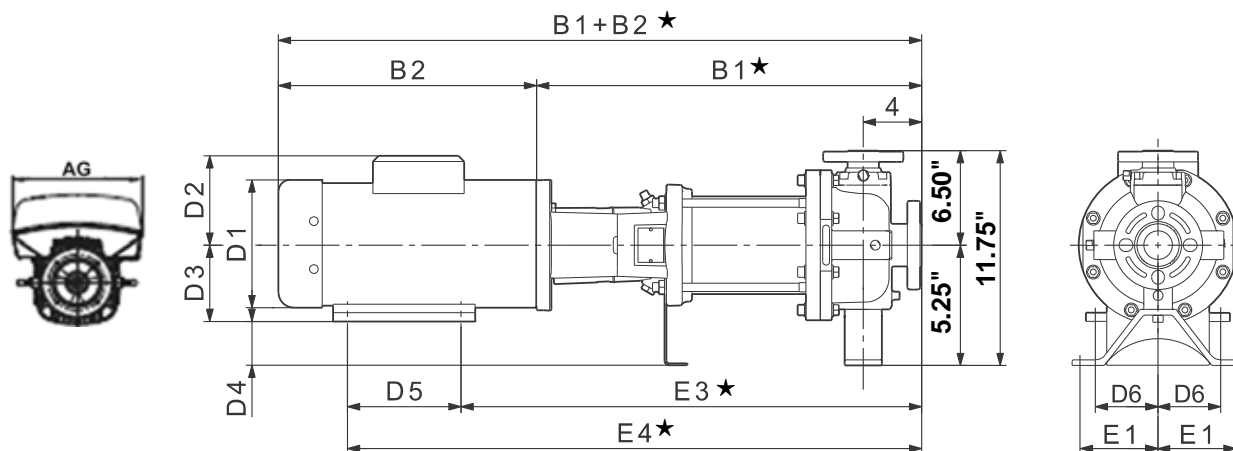

TM06 9699 1014 - TM04 4818 0310

Pump type	HP	PH	Dimensions [in] TEFC											Ship. wt. [lbs]	Dimensions [in] ODP			Dimensions [in] MLE*				Ship. wt. [lbs]
			B1 ★	B1+B2 ★	E1	E ★	E4 ★	D1	D2	D3	D4	D5	D6		D1	D2	B1+B2 ★	D1	D2	AG	B1+B2 ★	
CR(N)(E) 20-1 H	3	1	21.50	36.13	3.00	25.13	29.63	8.63	6.75	4.50	0.75	4.50	3.75	143	-	-	-	-	-	-	-	
		3	21.50	34.75	3.00	25.13	29.63	7.00	4.38	4.50	0.75	4.50	3.75	115	-	-	-	4.80	6.22	10.56	32.33	180
CR(N)(E) 20-2 H	5	1	21.50	37.00	3.00	25.25	29.75	10.63	8.00	5.25	0.00	4.50	3.75	258	-	-	-	-	-	-	-	
		3	21.50	37.00	3.00	25.25	29.75	8.63	5.25	4.50	0.75	4.50	3.75	251	-	-	-	7.53	7.91	11.46	34.65	203
CR(N)(E) 20-3 H	7 1/2	1	23.75	39.38	3.00	28.25	33.75	10.25	7.63	5.25	0.00	5.50	4.25	271	-	-	-	-	-	-	-	
		3	23.75	39.25	3.00	28.25	33.75	8.63	5.25	5.25	0.00	5.50	4.25	260	-	-	-	7.53	7.91	11.46	38.12	242
CR(N)(E) 20-4 H	10	1	25.63	41.63	3.00	30.13	37.13	10.25	10.25	5.25	0.00	7.00	4.25	317	-	-	-	-	-	-	-	
		3	25.63	40.75	3.00	30.13	37.13	10.25	6.25	5.25	0.00	7.00	4.25	262	-	-	-	10.04	9.33	13.62	40.94	247
CR(N) 20-5 H	15	3	28.00	46.50	3.00	33.00	41.25	12.38	8.00	6.25	-1.00	8.25	5.00	333	10.63	8.00	46.25	10.04	9.33	13.62	43.98	317
CR(N) 20-6 H	15	3	29.75	48.38	3.00	34.75	43.00	12.38	8.00	6.25	-1.00	8.25	5.00	355	10.63	8.00	48.00	10.04	9.33	13.62	45.73	321
CR(N) 20-7 H	20	3	31.50	50.13	3.00	36.50	46.50	12.38	8.00	6.25	-1.00	10.00	5.00	370	11.50	9.00	49.50	13.39	12.13	16.54	50.28	584
CR(N) 20-8 H	20	3	33.38	51.88	3.00	38.38	48.38	12.38	8.00	6.25	-1.00	10.00	5.00	374	11.50	9.00	51.25	13.39	12.13	16.54	52.16	588
CR(N) 20-10 H	25	3	36.00	58.38	3.00	41.00	50.50	12.38	8.00	7.00	-1.75	9.50	5.50	465	11.50	11.38	55.13	13.39	12.13	16.54	58.72	626

Note: Terminal box is on top of ML motors (through 30 HP). Baldor motors have terminal box on the side (40 HP and larger). Reference D2 dimension. Weights are based on pump with TEFC motor.

\* Dimensions shown for three-phase MLE motors are for 460 V versions. See page 19 for 200-240 V, three-phase dimensions.

**CR, CRE, CRN, CRNE 32 H G22**

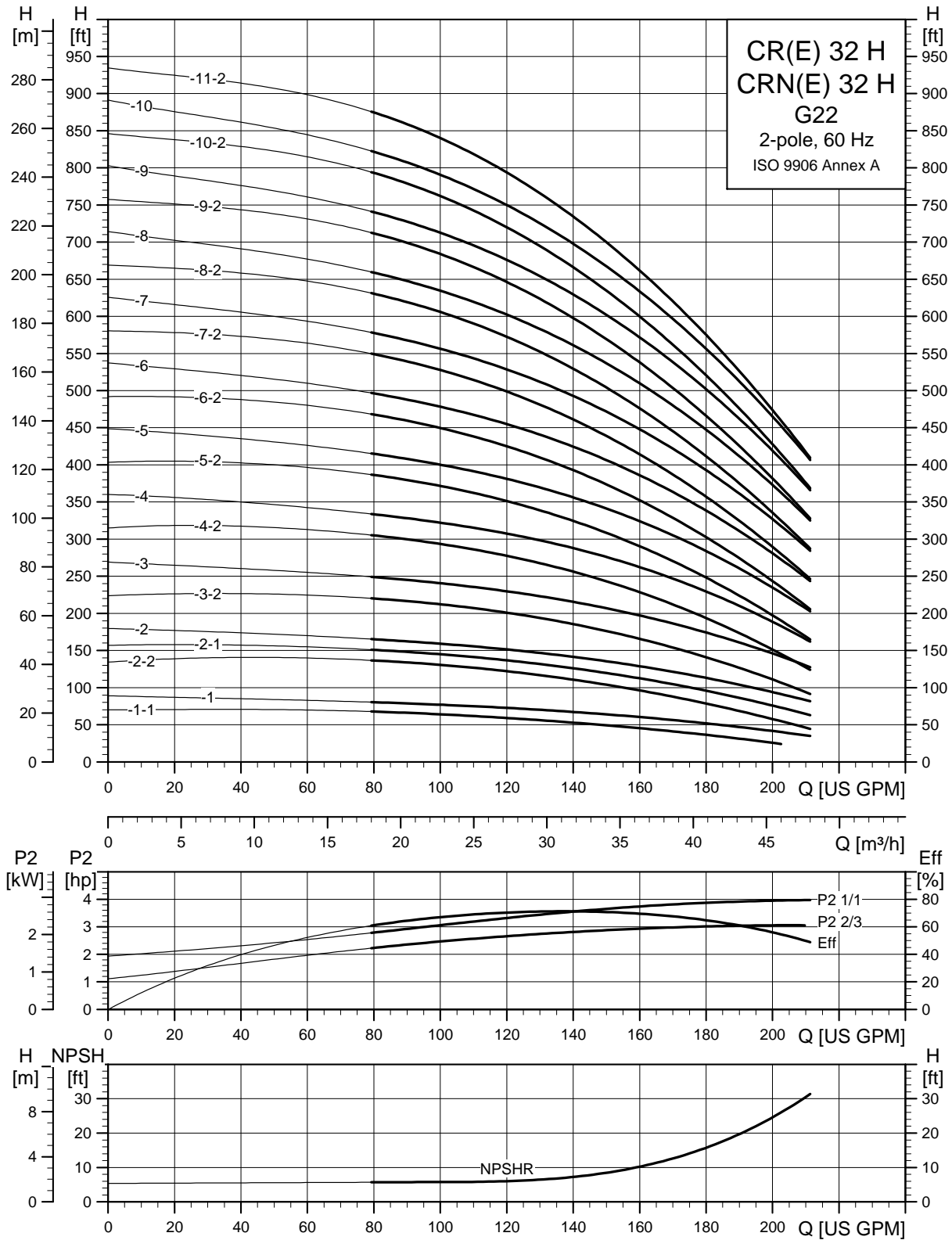

TM04 6295 0912

Dimensions and weights G22 (2" x 2")

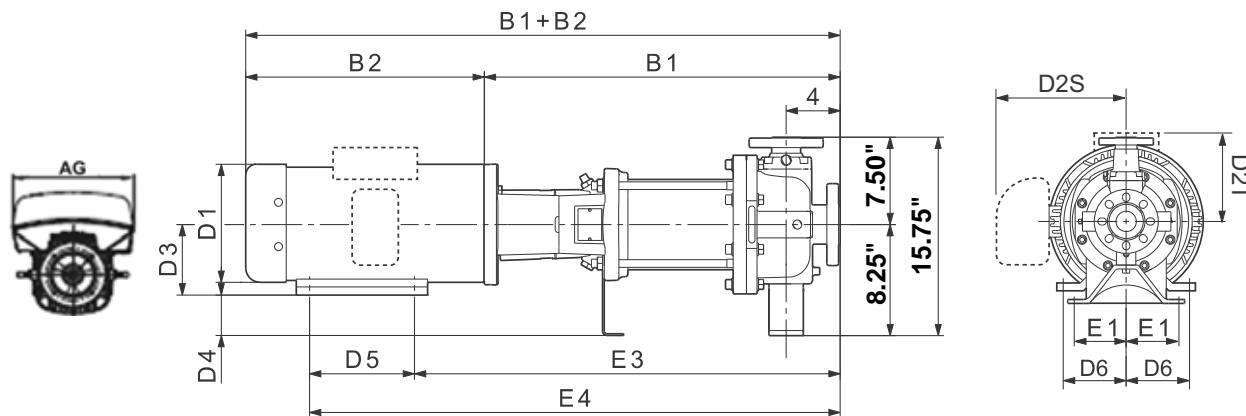

1514 1514 1063 06TM - TM06 9699 1014

Pump type	HP	PH	Dimensions [in] TEFC											Ship. wt. [lbs]	Dimensions [in] ODP			Dimensions [in] MLE*				Ship. wt. [lbs]			
			B1	B1+B2	E1	E3	E4	D1	D2T	D2S	D3	D4	D5		D6	D1	D2	B1+B2	D1	D2	AG		B1+B2		
CR(N) 32-1-1 H	5	1	25.00	40.50	4.88	28.75	33.25	10.63	8.00	-	5.25	3.00	4.50	3.75	353	-	-	-	-	-	-	-	-	-	
		3	25.00	40.50	4.88	28.75	33.25	8.63	5.25	-	4.50	3.75	4.50	3.75	335	-	-	-	-	-	-	-	-	-	-
CR(N)(E) 32-1 H	5	1	25.00	40.50	4.88	28.75	33.25	10.63	8.00	-	5.25	3.00	4.50	3.75	353	-	-	-	-	-	-	-	-	-	-
		3	25.00	40.50	4.88	28.75	33.25	8.63	5.25	-	4.50	3.75	4.50	3.75	335	-	-	-	7.53	7.91	11.46	38.15	-	-	309
CR(N) 32-2-2 H	7 1/2	1	28.25	43.75	4.88	32.75	38.25	10.25	7.63	-	5.25	3.00	5.50	4.25	371	-	-	-	-	-	-	-	-	-	-
		3	28.25	43.75	4.88	32.75	38.25	8.63	5.25	-	5.25	3.00	5.50	4.25	351	-	-	-	7.53	7.91	11.46	42.62	-	-	341
CR(N)(E) 32-2-1 H	7 1/2	1	28.25	43.75	4.88	32.75	38.25	10.25	7.63	-	5.25	3.00	5.50	4.25	371	-	-	-	-	-	-	-	-	-	-
		3	28.25	43.75	4.88	32.75	38.25	8.63	5.25	-	5.25	3.00	5.50	4.25	351	-	-	-	7.53	7.91	11.46	42.62	-	-	341
CR(N) 32-2 H	10	1	28.25	44.25	4.88	32.75	39.75	10.25	10.25	-	5.25	3.00	7.00	4.25	426	-	-	-	-	-	-	-	-	-	-
		3	28.25	43.38	4.88	32.75	39.75	10.25	6.25	-	5.25	3.00	7.00	4.25	374	-	-	-	10.04	9.33	13.62	43.56	-	-	343
CR(N)(E) 32-3-2 H	10	1	31.00	47.00	4.88	35.50	42.50	10.25	10.25	-	5.25	3.00	7.00	4.25	453	-	-	-	-	-	-	-	-	-	-
		3	31.00	46.13	4.88	35.50	42.50	10.25	6.25	-	5.25	3.00	7.00	4.25	400	-	-	-	10.04	9.33	13.62	46.31	-	-	370
CR(N) 32-3 H	15	3	30.50	49.00	4.88	35.50	43.75	12.38	8.00	-	6.25	2.00	8.25	5.00	479	10.63	8.00	48.63	10.04	9.33	13.62	46.48	-	-	434
CR(N)(E) 32-4-2 H	15	3	33.25	51.75	4.88	38.25	46.50	12.38	8.00	-	6.25	2.00	8.25	5.00	485	10.63	8.00	51.38	10.04	9.33	13.62	49.23	-	-	440
CR(N) 32-4 H	20	3	33.25	51.75	4.88	38.25	48.25	12.38	8.00	-	6.25	2.00	10.00	5.00	480	11.50	9.00	51.13	13.39	12.13	16.54	52.03	-	-	590
CR(N)(E) 32-5-2 H	20	3	36.00	54.50	4.88	41.00	51.00	12.38	8.00	-	6.25	2.00	10.00	5.00	487	11.50	9.00	53.88	13.39	12.13	16.54	54.78	-	-	597
CR(N)(E) 32-5 H	20	3	36.00	54.50	4.88	41.00	51.00	12.38	8.00	-	6.25	2.00	10.00	5.00	487	11.50	9.00	53.88	13.39	12.13	16.54	54.78	-	-	597
CR(N) 32-6-2 H	25	3	38.75	61.13	4.88	43.75	53.25	12.38	8.00	-	7.00	1.25	9.50	5.50	590	11.50	11.38	57.75	13.39	12.13	16.54	61.47	-	-	703
CR(N)(E) 32-6 H	25	3	38.75	61.13	4.88	43.75	53.25	12.38	8.00	-	7.00	1.25	9.50	5.50	590	11.50	11.38	57.75	13.39	12.13	16.54	61.47	-	-	703
CR(N) 32-7-2 H	30	3	41.50	63.88	4.88	46.50	57.50	12.38	8.00	-	7.00	1.25	11.00	5.50	623	11.50	11.38	62.00	13.39	12.13	16.54	64.22	-	-	738
CR(N)(E) 32-7 H	30	3	41.50	63.88	4.88	46.50	57.50	12.38	8.00	-	7.00	1.25	11.00	5.50	623	11.50	11.38	62.00	13.39	12.13	16.54	64.22	-	-	738
CR(N)(E) 32-8-2 H	30	3	44.25	66.63	4.88	49.25	60.25	12.38	8.00	-	7.00	1.25	11.00	5.50	636	11.50	11.38	64.75	13.39	12.13	16.54	66.97	-	-	751
CR(N) 32-8 H	40	3	44.25	67.38	4.88	49.25	60.25	15.00	-	13.13	7.00	1.25	11.00	5.50	887	13.25	12.25	65.38	-	-	-	-	-	-	-
CR(N) 32-9-2 H	40	3	47.00	70.25	4.88	52.00	63.00	15.00	-	13.13	7.00	1.25	11.00	5.50	896	13.25	12.25	68.25	-	-	-	-	-	-	-
CR(N) 32-9 H	40	3	47.00	70.25	4.88	52.00	63.00	15.00	-	13.13	7.00	1.25	11.00	5.50	896	13.25	12.25	68.25	-	-	-	-	-	-	-
CR(N) 32-10-2 H	40	3	49.75	73.00	4.88	54.75	65.75	15.00	-	13.13	7.00	1.25	11.00	5.50	912	13.25	12.25	71.00	-	-	-	-	-	-	-
CR(N) 32-10 H	40	3	49.75	73.00	4.88	54.75	65.75	15.00	-	13.13	7.00	1.25	11.00	5.50	912	13.25	12.25	71.00	-	-	-	-	-	-	-
CR(N) 32-11-2 H	50	3	52.50	77.88	4.88	58.00	70.00	16.88	-	14.50	8.00	0.25	12.00	6.25	974	13.25	12.25	74.75	-	-	-	-	-	-	-

Note: Terminal box is on top of ML motors (through 30 HP). Baldor motors have terminal box on the side (40 HP and larger). Reference D2 dimension. Weights are based on pump with TEFC motor.

\* Dimensions shown for three-phase MLE motors are for 460 V versions. See page 19 for 200-240 V, three-phase dimensions.

**CR, CRE, CRN, CRNE 32 H GA/G05**

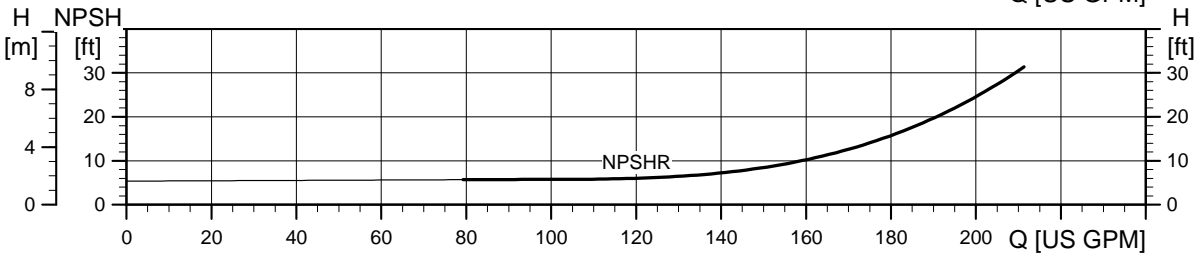
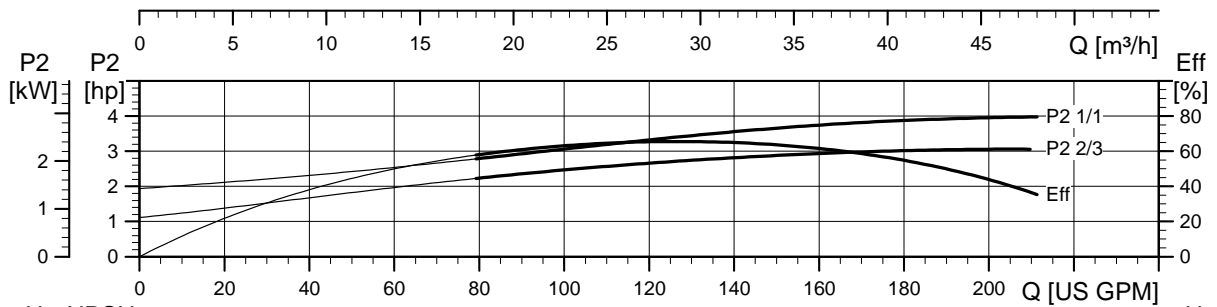
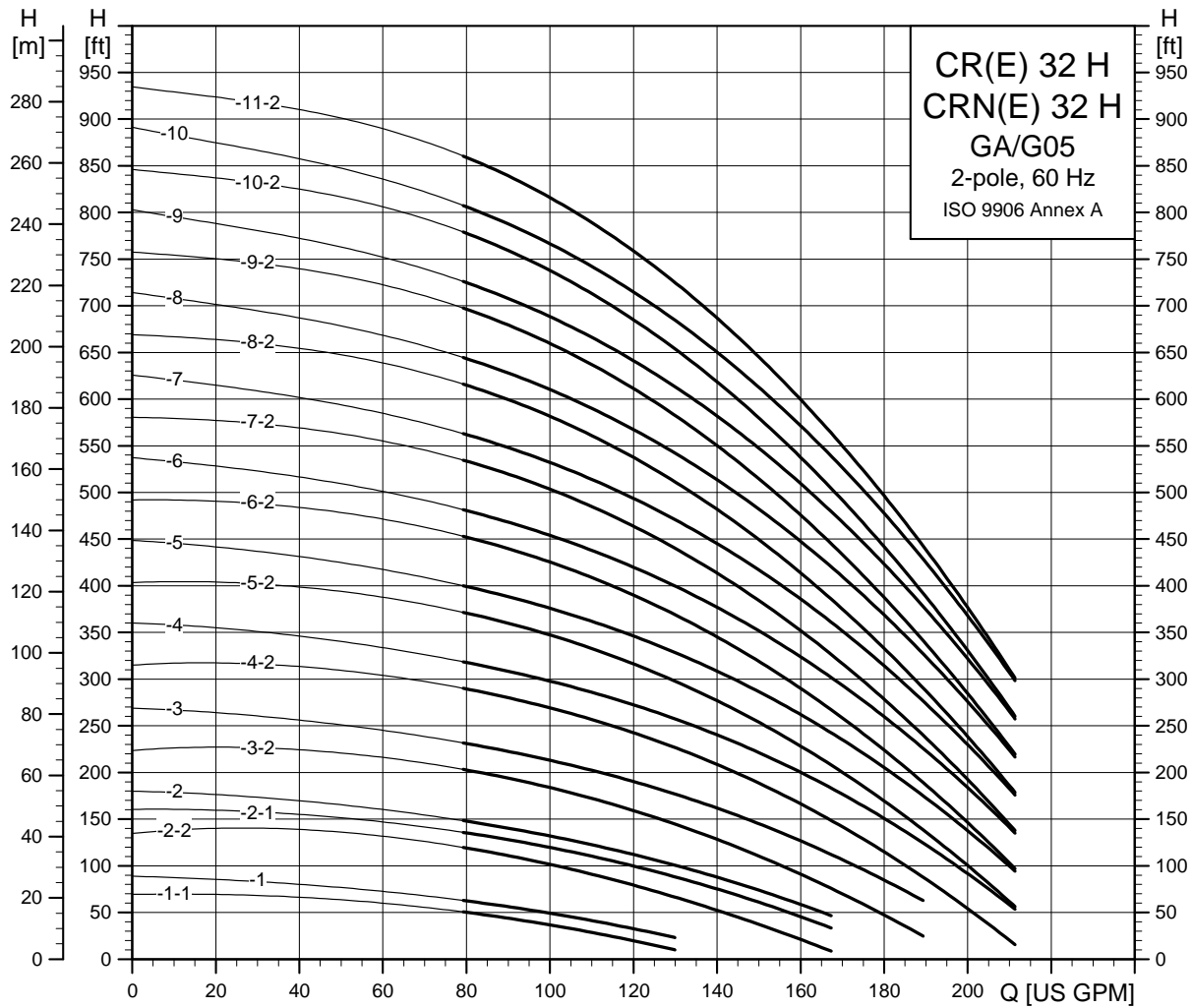

TM04 6292 0912

Dimensions and weights GA (1.5" x 1" x 6", 1.5" x 1" x 8")

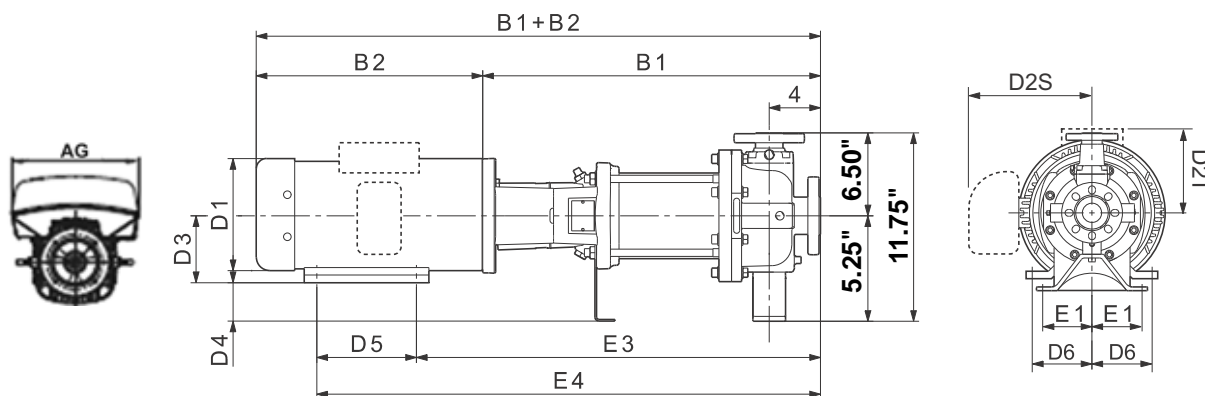

TM06 9699 1014 - TM06 1063 1514

Pump type	HP	PH	Dimensions [in] TEFC													Ship. wt. [lbs]	Dimensions [in] ODP			Dimensions [in] MLE*				Ship. wt. [lbs]	
			B1	B1+B2	E1	E3	E4	D1	D2T	D2S	D3	D4	D5	D6	D1		D2	B1+B2	D1	D2	AG	B1+B2			
CR(N) 32-1-1 H	5	1	25.00	40.50	3.00	28.75	33.25	10.63	8.00	-	5.25	0.00	4.50	3.75	344	-	-	-	-	-	-	-	-	-	
		3	25.00	40.50	3.00	28.75	33.25	8.63	5.25	-	4.50	0.75	4.50	3.75	327	-	-	-	-	-	-	-	-	-	-
CR(N)(E) 32-1 H	5	1	25.00	40.50	3.00	28.75	33.25	10.63	8.00	-	5.25	0.00	4.50	3.75	344	-	-	-	-	-	-	-	-	-	-
		3	25.00	40.50	3.00	28.75	33.25	8.63	5.25	-	4.50	0.75	4.50	3.75	327	-	-	-	7.53	7.91	11.46	38.15	-	300	
CR(N) 32-2-2 H	7 1/2	1	28.25	43.75	3.00	32.75	38.25	10.25	7.63	-	5.25	0.00	5.50	4.25	362	-	-	-	-	-	-	-	-	-	-
		3	28.25	43.75	3.00	32.75	38.25	8.63	5.25	-	5.25	0.00	5.50	4.25	342	-	-	-	7.53	7.91	11.46	42.62	-	332	
CR(N)(E) 32-2-1 H	7 1/2	1	28.25	43.75	3.00	32.75	38.25	10.25	7.63	-	5.25	0.00	5.50	4.25	362	-	-	-	-	-	-	-	-	-	-
		3	28.25	43.75	3.00	32.75	38.25	8.63	5.25	-	5.25	0.00	5.50	4.25	342	-	-	-	7.53	7.91	11.46	42.62	-	332	
CR(N) 32-2 H	10	1	28.25	44.25	3.00	32.75	39.75	10.25	10.25	-	5.25	0.00	7.00	4.25	417	-	-	-	-	-	-	-	-	-	-
		3	28.25	43.75	3.00	32.75	39.75	10.25	6.25	-	5.25	0.00	7.00	4.25	365	-	-	-	10.04	9.33	13.62	43.56	-	335	
CR(N)(E) 32-3-2 H	10	1	31.00	47.00	3.00	35.50	42.50	10.25	10.25	-	5.25	0.00	7.00	4.25	442	-	-	-	-	-	-	-	-	-	-
		3	31.00	46.13	3.00	35.50	42.50	10.25	6.25	-	5.25	0.00	7.00	4.25	389	-	-	-	10.04	9.33	13.62	46.31	-	359	
CR(N) 32-3 H	15	3	30.50	49.00	3.00	35.50	43.75	12.38	8.00	-	6.25	-1.00	8.25	5.00	468	10.63	8.00	48.63	10.04	9.33	13.62	46.48	-	423	
CR(N)(E) 32-4-2 H	15	3	33.25	51.75	3.00	38.25	46.50	12.38	8.00	-	6.25	-1.00	8.25	5.00	474	10.63	8.00	51.38	10.04	9.33	13.62	49.23	-	429	
CR(N) 32-4 H	20	3	33.25	51.75	3.00	38.25	48.25	12.38	8.00	-	6.25	-1.00	10.00	5.00	469	11.50	9.00	51.13	13.39	12.13	16.54	52.03	-	579	
CR(N)(E) 32-5-2 H	20	3	36.00	54.50	3.00	41.00	51.00	12.38	8.00	-	6.25	-1.00	10.00	5.00	476	11.50	9.00	53.88	13.39	12.13	16.54	54.78	-	586	
CR(N)(E) 32-5 H	20	3	36.00	54.50	3.00	41.00	51.00	12.38	8.00	-	6.25	-1.00	10.00	5.00	476	11.50	9.00	53.88	13.39	12.13	16.54	54.78	-	586	
CR(N) 32-6-2 H	25	3	38.75	61.13	3.00	43.75	53.25	12.38	8.00	-	7.00	-1.75	9.50	5.50	581	11.50	11.38	57.75	13.39	12.13	16.54	61.47	-	694	
CR(N)(E) 32-6 H	25	3	38.75	61.13	3.00	43.75	53.25	12.38	8.00	-	7.00	-1.75	9.50	5.50	581	11.50	11.38	57.75	13.39	12.13	16.54	61.47	-	694	
CR(N) 32-7-2 H	30	3	41.50	63.88	3.00	46.50	57.50	12.38	8.00	-	7.00	-1.75	11.00	5.50	614	11.50	11.38	62.00	13.39	12.13	16.54	64.22	-	729	
CR(N)(E) 32-7 H	30	3	41.50	63.88	3.00	46.50	57.50	12.38	8.00	-	7.00	-1.75	11.00	5.50	614	11.50	11.38	62.00	13.39	12.13	16.54	64.22	-	729	
CR(N)(E) 32-8-2 H	30	3	44.25	66.63	3.00	49.25	60.25	12.38	8.00	-	7.00	-1.75	11.00	5.50	627	11.50	11.38	64.75	13.39	12.13	16.54	66.97	-	743	
CR(N) 32-8 H	40	3	44.25	67.38	3.00	49.25	60.25	15.00	-	13.13	7.00	-1.75	11.00	5.50	879	13.25	12.25	65.38	-	-	-	-	-	-	
CR(N) 32-9-2 H	40	3	47.00	70.25	3.00	52.00	63.00	15.00	-	13.13	7.00	-1.75	11.00	5.50	887	13.25	12.25	68.25	-	-	-	-	-	-	
CR(N) 32-9 H	40	3	47.00	70.25	3.00	52.00	63.00	15.00	-	13.13	7.00	-1.75	11.00	5.50	887	13.25	12.25	68.25	-	-	-	-	-	-	
CR(N) 32-10-2 H	40	3	49.75	73.00	3.00	54.75	65.75	15.00	-	13.13	7.00	-1.75	11.00	5.50	903	13.25	12.25	71.00	-	-	-	-	-	-	
CR(N) 32-10 H	40	3	49.75	73.00	3.00	54.75	65.75	15.00	-	13.13	7.00	-1.75	11.00	5.50	903	13.25	12.25	71.00	-	-	-	-	-	-	
CR(N) 32-11-2 H	50	3	52.50	77.88	3.00	58.00	70.00	16.88	-	14.50	8.00	-2.75	12.00	6.25	965	13.25	12.25	74.75	-	-	-	-	-	-	

Note: Terminal box is on top of ML motors (through 30 HP). Baldor motors have terminal box on the side (40 HP and larger). Reference D2 dimension. Weights are based on pump with TEFC motor.

\* Dimensions shown for three-phase MLE motors are for 460 V versions. See page 19 for 200-240 V, three-phase dimensions.

Dimensions and weights G05 (2" x 1" x 10")

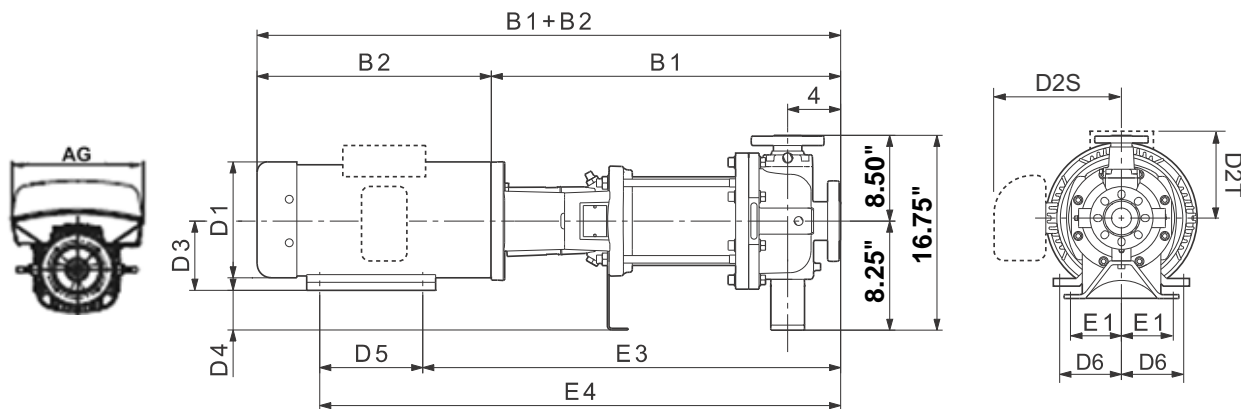

TM06 9699 1014 - TM06 1063 1514

Pump type	HP	PH	Dimensions [in] TEFC											Ship. wt. [lbs]	Dimensions [in] ODP			Dimensions [in] MLE*				Ship. wt. [lbs]	
			B1	B1+B2	E1	E3	E4	D1	D2T	D2S	D3	D4	D5		D6	D1	D2	B1+B2	D1	D2	AG		B1+B2
CR(N) 32-1-1 H	5	1	25.00	40.50	4.88	28.75	33.25	10.63	8.00	-	5.25	3.00	4.50	3.75	414	-	-	-	-	-	-	-	-
		3	25.00	40.50	4.88	28.75	33.25	8.63	5.25	-	4.50	3.75	4.50	3.75	397	-	-	-	-	-	-	-	-
CR(N)(E) 32-1 H	5	1	25.00	40.50	4.88	28.75	33.25	10.63	8.00	-	5.25	3.00	4.50	3.75	414	-	-	-	-	-	-	-	-
		3	25.00	40.50	4.88	28.75	33.25	8.63	5.25	-	4.50	3.75	4.50	3.75	397	-	-	-	7.53	7.91	11.46	38.15	370
CR(N) 32-2-2 H	7 1/2	1	28.25	43.75	4.88	32.75	38.25	10.25	7.63	-	5.25	3.00	5.50	4.25	431	-	-	-	-	-	-	-	-
		3	28.25	43.75	4.88	32.75	38.25	8.63	5.25	-	5.25	3.00	5.50	4.25	410	-	-	-	7.53	7.91	11.46	42.62	401
CR(N)(E) 32-2-1 H	7 1/2	1	28.25	43.75	4.88	32.75	38.25	10.25	7.63	-	5.25	3.00	5.50	4.25	431	-	-	-	-	-	-	-	-
		3	28.25	43.75	4.88	32.75	38.25	8.63	5.25	-	5.25	3.00	5.50	4.25	410	-	-	-	7.53	7.91	11.46	42.62	401
CR(N) 32-2 H	10	1	28.25	44.25	4.88	32.75	39.75	10.25	10.25	-	5.25	3.00	7.00	4.25	486	-	-	-	-	-	-	-	-
		3	28.25	43.38	4.88	32.75	39.75	10.25	6.25	-	5.25	3.00	7.00	4.25	433	-	-	-	10.04	9.33	13.62	43.56	403
CR(N)(E) 32-3-2 H	10	1	31.00	47.00	4.88	35.50	42.50	10.25	10.25	-	5.25	3.00	7.00	4.25	494	-	-	-	-	-	-	-	-
		3	31.00	46.13	4.88	35.50	42.50	10.25	6.25	-	5.25	3.00	7.00	4.25	442	-	-	-	10.04	9.33	13.62	46.31	412
CR(N) 32-3 H	15	3	30.50	49.00	4.88	35.50	43.75	12.38	8.00	-	6.25	2.00	8.25	5.00	521	10.63	8.00	48.63	10.04	9.33	13.62	46.48	475
CR(N)(E) 32-4-2 H	15	3	33.25	51.75	4.88	38.25	46.50	12.38	8.00	-	6.25	2.00	8.25	5.00	525	10.63	8.00	51.38	10.04	9.33	13.62	49.23	480
CR(N) 32-4 H	20	3	33.25	51.75	4.88	38.25	48.25	12.38	8.00	-	6.25	2.00	10.00	5.00	520	11.50	9.00	51.13	13.39	12.13	16.54	52.03	630
CR(N)(E) 32-5-2 H	20	3	36.00	54.50	4.88	41.00	51.00	12.38	8.00	-	6.25	2.00	10.00	5.00	528	11.50	9.00	53.88	13.39	12.13	16.54	54.78	639
CR(N)(E) 32-5 H	20	3	36.00	54.50	4.88	41.00	51.00	12.38	8.00	-	6.25	2.00	10.00	5.00	528	11.50	9.00	53.88	13.39	12.13	16.54	54.78	639
CR(N) 32-6-2 H	25	3	38.75	61.13	4.88	43.75	53.25	12.38	8.00	-	7.00	1.25	9.50	5.50	590	11.50	11.38	57.75	13.39	12.13	16.54	61.47	703
CR(N)(E) 32-6 H	25	3	38.75	61.13	4.88	43.75	53.25	12.38	8.00	-	7.00	1.25	9.50	5.50	590	11.50	11.38	57.75	13.39	12.13	16.54	61.47	703
CR(N) 32-7-2 H	30	3	41.50	63.88	4.88	46.50	57.50	12.38	8.00	-	7.00	1.25	11.00	5.50	623	11.50	11.38	62.00	13.39	12.13	16.54	64.22	738
CR(N)(E) 32-7 H	30	3	41.50	63.88	4.88	46.50	57.50	12.38	8.00	-	7.00	1.25	11.00	5.50	623	11.50	11.38	62.00	13.39	12.13	16.54	64.22	738
CR(N)(E) 32-8-2 H	30	3	44.25	66.63	4.88	49.25	60.25	12.38	8.00	-	7.00	1.25	11.00	5.50	636	11.50	11.38	64.75	13.39	12.13	16.54	66.97	751
CR(N) 32-8 H	40	3	44.25	67.38	4.88	49.25	60.25	15.00	-	13.13	7.00	1.25	11.00	5.50	887	13.25	12.25	65.38	-	-	-	-	-
CR(N) 32-9-2 H	40	3	47.00	70.25	4.88	52.00	63.00	15.00	-	13.13	7.00	1.25	11.00	5.50	894	13.25	12.25	68.25	-	-	-	-	-
CR(N) 32-9 H	40	3	47.00	70.25	4.88	52.00	63.00	15.00	-	13.13	7.00	1.25	11.00	5.50	894	13.25	12.25	68.25	-	-	-	-	-
CR(N) 32-10-2 H	40	3	49.75	73.00	4.88	54.75	65.75	15.00	-	13.13	7.00	1.25	11.00	5.50	912	13.25	12.25	71.00	-	-	-	-	-
CR(N) 32-10 H	40	3	49.75	73.00	4.88	54.75	65.75	15.00	-	13.13	7.00	1.25	11.00	5.50	912	13.25	12.25	71.00	-	-	-	-	-
CR(N) 32-11-2 H	50	3	52.50	77.88	4.88	58.00	70.00	16.88	-	14.50	8.00	0.25	12.00	6.25	974	13.25	12.25	74.75	-	-	-	-	-

Note: Terminal box is on top of ML motors (through 30 HP). Baldor motors have terminal box on the side (40 HP and larger). Reference D2 dimension. Weights are based on pump with TEFC motor.

\* Dimensions shown for three-phase MLE motors are for 460 V versions. See page 19 for 200-240 V, three-phase dimensions.

**CR, CRE, CRN, CRNE 32 H GB/G50**

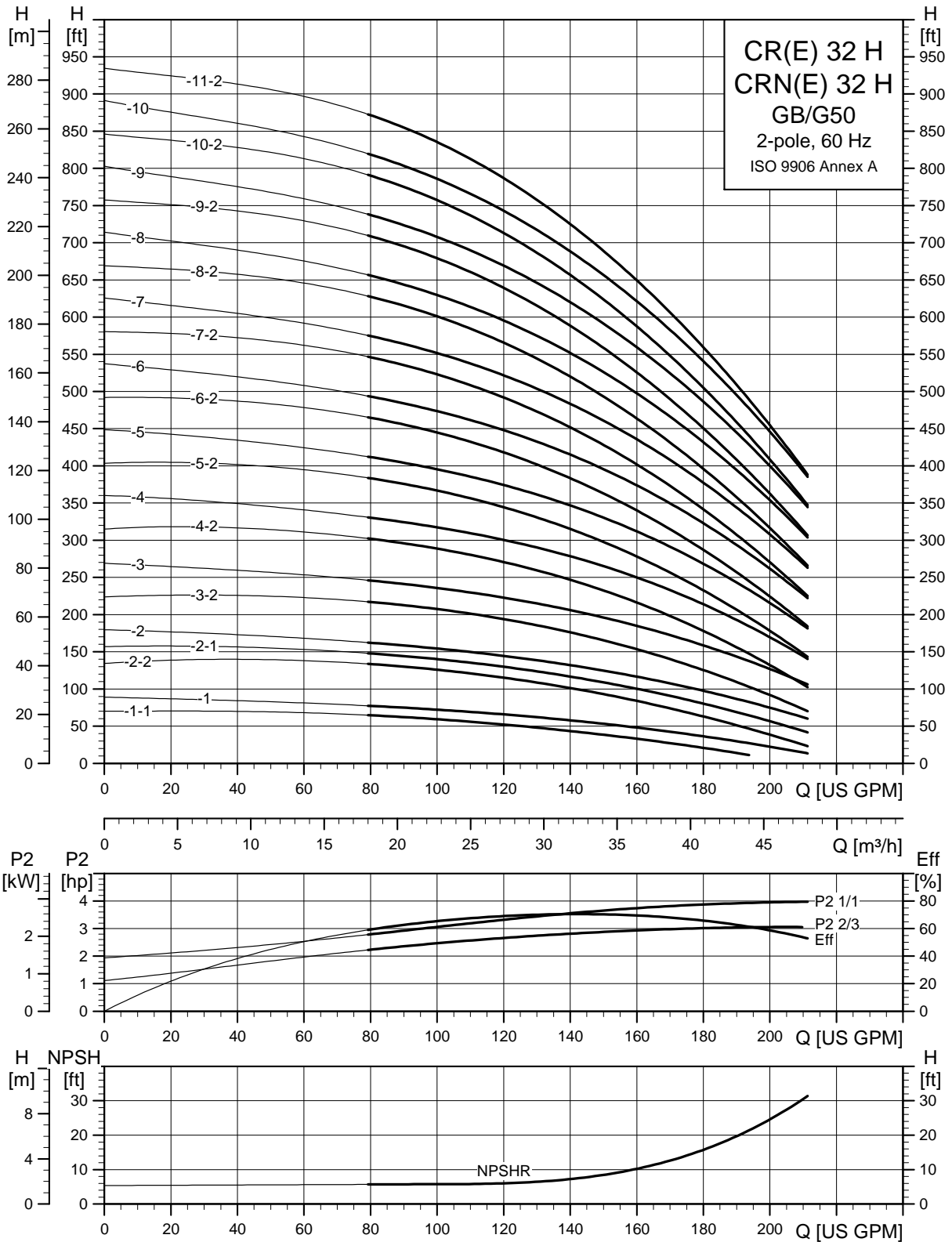

TM04 6293 0912

Dimensions and weights GB (3" x 1.5" x 6", 3" x 1.5" x 8")

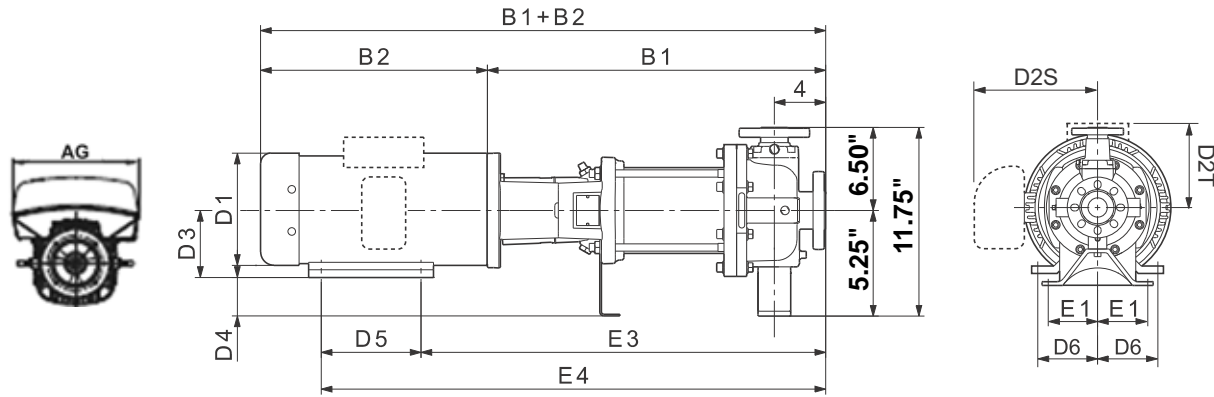

TM06 9699 1014 - TM06 1063 1514

Pump type	HP	PH	Dimensions [in] TEFC													Ship. wt. [lbs]	Dimensions [in] ODP			Dimensions [in] MLE*				Ship. wt. [lbs]
			B1	B1+B2	E1	E3	E4	D1	D2T	D2S	D3	D4	D5	D6	D1		D2	B1+B2	D1	D2	AG	B1+B2		
CR(N) 32-1-1 H	5	1	26.00	41.50	3.00	29.75	34.25	10.63	8.00	-	5.25	0.00	4.50	3.75	359	-	-	-	-	-	-	-	-	
		3	26.00	41.50	3.00	29.75	34.25	8.63	5.25	-	4.50	0.75	4.50	3.75	342	-	-	-	-	-	-	-	-	
CR(N)(E) 32-1 H	5	1	26.00	41.50	3.00	29.75	34.25	10.63	8.00	-	5.25	0.00	4.50	3.75	359	-	-	-	-	-	-	-	-	
		3	26.00	41.50	3.00	29.75	34.25	8.63	5.25	-	4.50	0.75	4.50	3.75	342	-	-	-	7.53	7.91	11.46	39.15	315	
CR(N) 32-2-2 H	7 1/2	1	29.25	44.75	3.00	33.75	39.25	10.25	7.63	-	5.25	0.00	5.50	4.25	378	-	-	-	-	-	-	-	-	
		3	29.25	44.75	3.00	33.75	39.25	8.63	5.25	-	5.25	0.00	5.50	4.25	357	-	-	-	7.53	7.91	11.46	43.62	348	
CR(N)(E) 32-2-1 H	7 1/2	1	29.25	44.75	3.00	33.75	39.25	10.25	7.63	-	5.25	0.00	5.50	4.25	378	-	-	-	-	-	-	-	-	
		3	29.25	44.75	3.00	33.75	39.25	8.63	5.25	-	5.25	0.00	5.50	4.25	357	-	-	-	7.53	7.91	11.46	43.62	348	
CR(N) 32-2 H	10	1	29.25	45.38	3.00	33.75	40.75	10.25	10.25	-	5.25	0.00	7.00	4.25	433	-	-	-	-	-	-	-	-	
		3	29.25	44.38	3.00	33.75	40.75	10.25	6.25	-	5.25	0.00	7.00	4.25	381	-	-	-	10.04	9.33	13.62	44.56	350	
CR(N)(E) 32-3-2 H	10	1	32.00	48.13	3.00	36.50	43.50	10.25	10.25	-	5.25	0.00	7.00	4.25	459	-	-	-	-	-	-	-	-	
		3	32.00	47.13	3.00	36.50	43.50	10.25	6.25	-	5.25	0.00	7.00	4.25	407	-	-	-	10.04	9.33	13.62	47.31	376	
CR(N) 32-3 H	15	3	31.50	50.00	3.00	36.50	44.75	12.38	8.00	-	6.25	-1.00	8.25	5.00	485	10.63	8.00	49.63	10.04	9.33	13.62	47.48	440	
CR(N)(E) 32-4-2 H	15	3	34.25	52.75	3.00	39.25	47.50	12.38	8.00	-	6.25	-1.00	8.25	5.00	492	10.63	8.00	52.38	10.04	9.33	13.62	50.23	447	
CR(N) 32-4 H	20	3	34.25	52.75	3.00	39.25	49.25	12.38	8.00	-	6.25	-1.00	10.00	5.00	487	11.50	9.00	52.13	13.39	12.13	16.54	53.03	597	
CR(N)(E) 32-5-2 H	20	3	37.00	55.50	3.00	42.00	52.00	12.38	8.00	-	6.25	-1.00	10.00	5.00	493	11.50	9.00	55.00	13.39	12.13	16.54	55.78	603	
CR(N)(E) 32-5 H	20	3	37.00	55.50	3.00	42.00	52.00	12.38	8.00	-	6.25	-1.00	10.00	5.00	493	11.50	9.00	55.00	13.39	12.13	16.54	55.78	603	
CR(N) 32-6-2 H	25	3	39.75	62.13	3.00	44.75	54.25	12.38	8.00	-	7.00	-1.75	9.50	5.50	601	11.50	11.38	58.88	13.39	12.13	16.54	62.47	714	
CR(N)(E) 32-6 H	25	3	39.75	62.13	3.00	44.75	54.25	12.38	8.00	-	7.00	-1.75	9.50	5.50	601	11.50	11.38	58.88	13.39	12.13	16.54	62.47	714	
CR(N) 32-7-2 H	30	3	42.50	64.88	3.00	47.50	58.50	12.38	8.00	-	7.00	-1.75	11.00	5.50	634	11.50	11.38	63.13	13.39	12.13	16.54	65.22	749	
CR(N)(E) 32-7 H	30	3	42.50	64.88	3.00	47.50	58.50	12.38	8.00	-	7.00	-1.75	11.00	5.50	634	11.50	11.38	63.13	13.39	12.13	16.54	65.22	749	
CR(N)(E) 32-8-2 H	30	3	45.25	67.63	3.00	50.25	61.25	12.38	8.00	-	7.00	-1.75	11.00	5.50	647	11.50	11.38	65.88	13.39	12.13	16.54	67.97	762	
CR(N) 32-8 H	40	3	45.25	68.50	3.00	50.25	61.25	15.00	-	13.13	7.00	-1.75	11.00	5.50	898	13.25	12.25	66.50	-	-	-	-	-	
CR(N) 32-9-2 H	40	3	48.00	71.25	3.00	53.00	64.00	15.00	-	13.13	7.00	-1.75	11.00	5.50	914	13.25	12.25	69.25	-	-	-	-	-	
CR(N) 32-9 H	40	3	48.00	71.25	3.00	53.00	64.00	15.00	-	13.13	7.00	-1.75	11.00	5.50	914	13.25	12.25	69.25	-	-	-	-	-	
CR(N) 32-10-2 H	40	3	50.75	74.00	3.00	55.75	66.75	15.00	-	13.13	7.00	-1.75	11.00	5.50	923	13.25	12.25	72.00	-	-	-	-	-	
CR(N) 32-10 H	40	3	50.75	74.00	3.00	55.75	66.75	15.00	-	13.13	7.00	-1.75	11.00	5.50	923	13.25	12.25	72.00	-	-	-	-	-	
CR(N) 32-11-2 H	50	3	53.50	79.00	3.00	59.00	71.00	16.88	-	14.50	8.00	-2.75	12.00	6.25	985	13.25	12.25	75.75	-	-	-	-	-	

Note: Terminal box is on top of ML motors (through 30 HP). Baldor motors have terminal box on the side (40 HP and larger). Reference D2 dimension. Weights are based on pump with TEFC motor.

\* Dimensions shown for three-phase MLE motors are for 460 V versions. See page 19 for 200-240 V, three-phase dimensions.

Dimensions and weights G50 (3" x 1.5" x 8", 3" x 1.5" x 10")

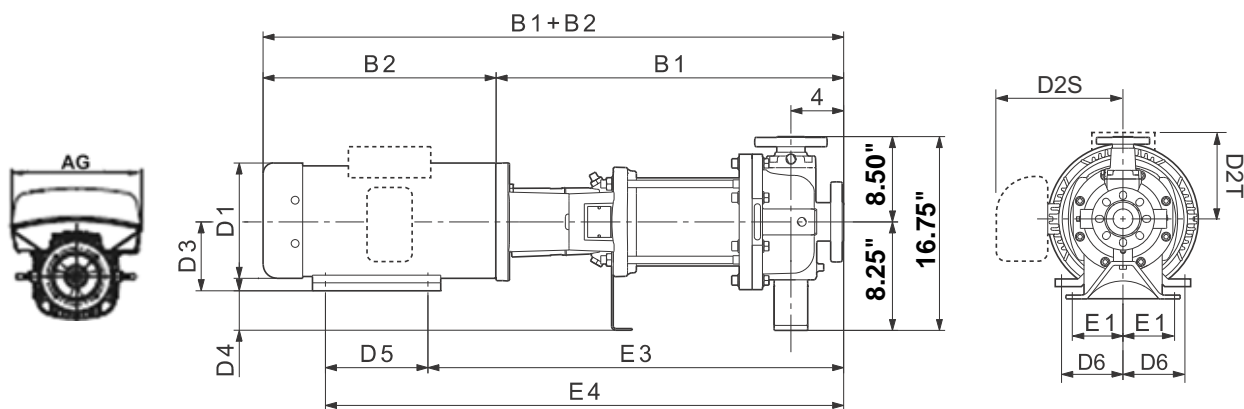

TM06 9699 1014 - TM06 1063 1514

Pump type	HP	PH	Dimensions [in] TEFC											Ship. wt. [lbs]	Dimensions [in] ODP			Dimensions [in] MLE*				Ship. wt. [lbs]			
			B1	B1+B2	E1	E3	E4	D1	D2T	D2S	D3	D4	D5		D6	D1	D2	B1+B2	D1	D2	AG		B1+B2		
CR(N) 32-1-1 H	5	1	26.00	41.50	4.88	29.75	34.25	10.63	8.00	-	5.25	3.00	4.50	3.75	419	-	-	-	-	-	-	-	-	-	
		3	26.00	41.50	4.88	29.75	34.25	8.63	5.25	-	4.50	3.75	4.50	3.75	401	-	-	-	-	-	-	-	-	-	-
CR(N)(E) 32-1 H	5	1	26.00	41.50	4.88	29.75	34.25	10.63	8.00	-	5.25	3.00	4.50	3.75	419	-	-	-	-	-	-	-	-	-	-
		3	26.00	41.50	4.88	29.75	34.25	8.63	5.25	-	4.50	3.75	4.50	3.75	401	-	-	-	7.53	7.91	11.46	39.15	-	375	
CR(N) 32-2-2 H	7 1/2	1	29.25	44.75	4.88	33.75	39.25	10.25	7.63	-	5.25	3.00	5.50	4.25	437	-	-	-	-	-	-	-	-	-	-
		3	29.25	44.75	4.88	33.75	39.25	8.63	5.25	-	5.25	3.00	5.50	4.25	417	-	-	-	7.53	7.91	11.46	43.62	-	407	
CR(N)(E) 32-2-1 H	7 1/2	1	29.25	44.75	4.88	33.75	39.25	10.25	7.63	-	5.25	3.00	5.50	4.25	437	-	-	-	-	-	-	-	-	-	-
		3	29.25	44.75	4.88	33.75	39.25	8.63	5.25	-	5.25	3.00	5.50	4.25	417	-	-	-	7.53	7.91	11.46	43.62	-	407	
CR(N) 32-2 H	10	1	29.25	45.38	4.88	33.75	40.75	10.25	10.25	-	5.25	3.00	7.00	4.25	492	-	-	-	-	-	-	-	-	-	-
		3	29.25	44.38	4.88	33.75	40.75	10.25	6.25	-	5.25	3.00	7.00	4.25	440	-	-	-	10.04	9.33	13.62	44.56	-	409	
CR(N)(E) 32-3-2 H	10	1	32.00	48.13	4.88	36.50	43.50	10.25	10.25	-	5.25	3.00	7.00	4.25	499	-	-	-	-	-	-	-	-	-	-
		3	32.00	47.13	4.88	36.50	43.50	10.25	6.25	-	5.25	3.00	7.00	4.25	447	-	-	-	10.04	9.33	13.62	47.31	-	416	
CR(N) 32-3 H	15	3	31.50	50.00	4.88	36.50	44.75	12.38	8.00	-	6.25	2.00	8.25	5.00	525	10.63	8.00	49.63	10.04	9.33	13.62	47.48	-	480	
CR(N)(E) 32-4-2 H	15	3	34.25	52.75	4.88	39.25	47.50	12.38	8.00	-	6.25	2.00	8.25	5.00	532	10.63	8.00	52.38	10.04	9.33	13.62	50.23	-	486	
CR(N) 32-4 H	20	3	34.25	52.75	4.88	39.25	49.25	12.38	8.00	-	6.25	2.00	10.00	5.00	526	11.50	9.00	52.13	13.39	12.13	16.54	53.03	-	636	
CR(N)(E) 32-5-2 H	20	3	37.00	55.50	4.88	42.00	52.00	12.38	8.00	-	6.25	2.00	10.00	5.00	533	11.50	9.00	55.00	13.39	12.13	16.54	55.78	-	643	
CR(N)(E) 32-5 H	20	3	37.00	55.50	4.88	42.00	52.00	12.38	8.00	-	6.25	2.00	10.00	5.00	533	11.50	9.00	55.00	13.39	12.13	16.54	55.78	-	643	
CR(N) 32-6-2 H	25	3	39.75	62.13	4.88	44.75	54.25	12.38	8.00	-	7.00	1.25	9.50	5.50	599	11.50	11.38	58.88	13.39	12.13	16.54	62.47	-	711	
CR(N)(E) 32-6 H	25	3	39.75	62.13	4.88	44.75	54.25	12.38	8.00	-	7.00	1.25	9.50	5.50	599	11.50	11.38	58.88	13.39	12.13	16.54	62.47	-	711	
CR(N) 32-7-2 H	30	3	42.50	64.88	4.88	47.50	58.50	12.38	8.00	-	7.00	1.25	11.00	5.50	632	11.50	11.38	63.13	13.39	12.13	16.54	65.22	-	747	
CR(N)(E) 32-7 H	30	3	42.50	64.88	4.88	47.50	58.50	12.38	8.00	-	7.00	1.25	11.00	5.50	632	11.50	11.38	63.13	13.39	12.13	16.54	65.22	-	747	
CR(N)(E) 32-8-2 H	30	3	45.25	67.63	4.88	50.25	61.25	12.38	8.00	-	7.00	1.25	11.00	5.50	645	11.50	11.38	65.88	13.39	12.13	16.54	67.97	-	760	
CR(N) 32-8 H	40	3	45.25	68.50	4.88	50.25	61.25	15.00	-	13.13	7.00	1.25	11.00	5.50	896	13.25	12.25	66.50	-	-	-	-	-	-	
CR(N) 32-9-2 H	40	3	48.00	71.25	4.88	53.00	64.00	15.00	-	13.13	7.00	1.25	11.00	5.50	914	13.25	12.25	69.25	-	-	-	-	-	-	
CR(N) 32-9 H	40	3	48.00	71.25	4.88	53.00	64.00	15.00	-	13.13	7.00	1.25	11.00	5.50	914	13.25	12.25	69.25	-	-	-	-	-	-	
CR(N) 32-10-2 H	40	3	50.75	74.00	4.88	55.75	66.75	15.00	-	13.13	7.00	1.25	11.00	5.50	920	13.25	12.25	72.00	-	-	-	-	-	-	
CR(N) 32-10 H	40	3	50.75	74.00	4.88	55.75	66.75	15.00	-	13.13	7.00	1.25	11.00	5.50	920	13.25	12.25	72.00	-	-	-	-	-	-	
CR(N) 32-11-2 H	50	3	53.50	79.00	4.88	59.00	71.00	16.88	-	14.50	8.00	0.25	12.00	6.25	982	13.25	12.25	75.75	-	-	-	-	-	-	

Note: Terminal box is on top of ML motors (through 30 HP). Baldor motors have terminal box on the side (40 HP and larger). Reference D2 dimension. Weights are based on pump with TEFC motor.

\* Dimensions shown for three-phase MLE motors are for 460 V versions. See page 19 for 200-240 V, three-phase dimensions.

**CR, CRE, CRN, CRNE 32 H GC/G10/G60**

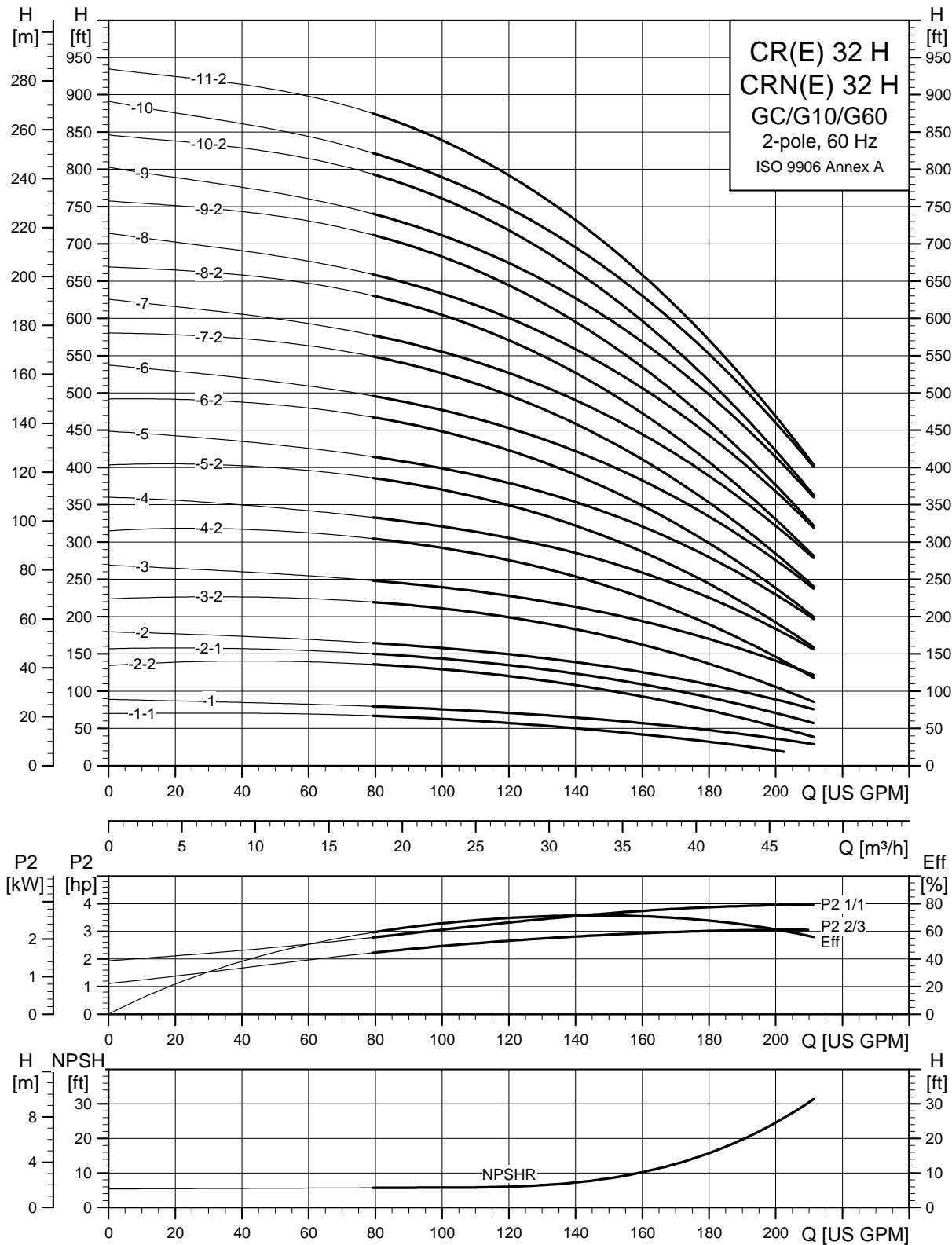

TM04 6294 0912

Dimensions and weights GC (3" x 2" x 6")

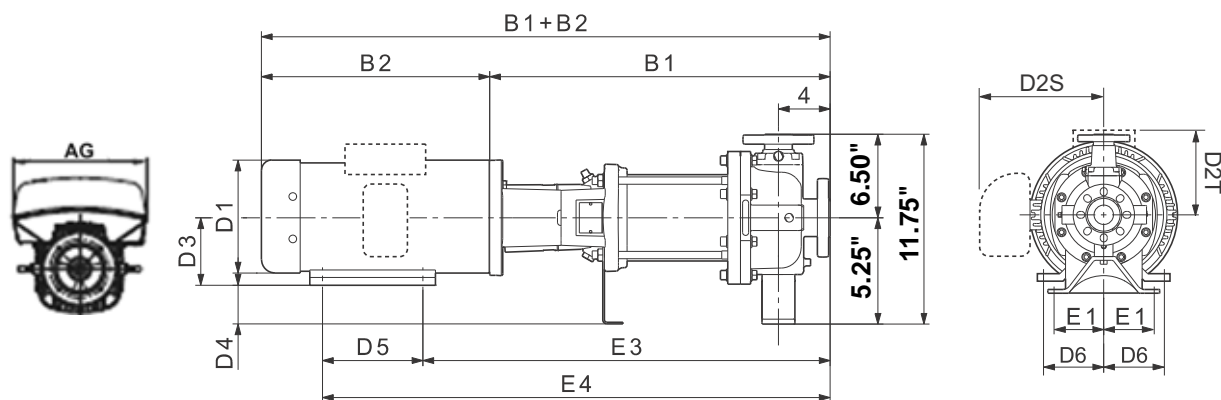

TM06 9699 1014 - TM06 1063 1514

Pump type	HP	PH	Dimensions [in] TEFC													Ship. wt. [lbs]	Dimensions [in] ODP			Dimensions [in] MLE*				Ship. wt. [lbs]
			B1	B1+B2	E1	E3	E4	D1	D2T	D2S	D3	D4	D5	D6	D1		D2	B1+B2	D1	D2	AG	B1+B2		
CR(N) 32-1-1 H	5	1	26.00	41.50	3.00	29.75	34.25	10.63	8.00	-	5.25	0.00	4.50	3.75	353	-	-	-	-	-	-	-	-	-
		3	26.00	41.50	3.00	29.75	34.25	8.63	5.25	-	4.50	0.75	4.50	3.75	335	-	-	-	-	-	-	-	-	-
CR(N)(E) 32-1 H	5	1	26.00	41.50	3.00	29.75	34.25	10.63	8.00	-	5.25	0.00	4.50	3.75	353	-	-	-	-	-	-	-	-	-
		3	26.00	41.50	3.00	29.75	34.25	8.63	5.25	-	4.50	0.75	4.50	3.75	335	-	-	-	7.53	7.91	11.46	39.15	-	309
CR(N) 32-2-2 H	7 1/2	1	29.25	44.75	3.00	33.75	39.25	10.25	7.63	-	5.25	0.00	5.50	4.25	371	-	-	-	-	-	-	-	-	-
		3	29.25	44.75	3.00	33.75	39.25	8.63	5.25	-	5.25	0.00	5.50	4.25	351	-	-	-	7.53	7.91	11.46	43.62	-	341
CR(N)(E) 32-2-1 H	7 1/2	1	29.25	44.75	3.00	33.75	39.25	10.25	7.63	-	5.25	0.00	5.50	4.25	371	-	-	-	-	-	-	-	-	-
		3	29.25	44.75	3.00	33.75	39.25	8.63	5.25	-	5.25	0.00	5.50	4.25	351	-	-	-	7.53	7.91	11.46	43.62	-	341
CR(N) 32-2 H	10	1	29.25	45.38	3.00	33.75	40.75	10.25	10.25	-	5.25	0.00	7.00	4.25	426	-	-	-	-	-	-	-	-	-
		3	29.25	44.38	3.00	33.75	40.75	10.25	6.25	-	5.25	0.00	7.00	4.25	374	-	-	-	10.04	9.33	13.62	44.56	-	343
CR(N)(E) 32-3-2 H	10	1	32.00	48.13	3.00	36.50	43.50	10.25	10.25	-	5.25	0.00	7.00	4.25	453	-	-	-	-	-	-	-	-	-
		3	32.00	47.13	3.00	36.50	43.50	10.25	6.25	-	5.25	0.00	7.00	4.25	400	-	-	-	10.04	9.33	13.62	47.31	-	370
CR(N) 32-3 H	15	3	31.50	50.00	3.00	36.50	44.75	12.38	8.00	-	6.25	-1.00	8.25	5.00	479	10.63	8.00	49.63	10.04	9.33	13.62	47.48	-	434
CR(N)(E) 32-4-2 H	15	3	34.25	52.75	3.00	39.25	47.50	12.38	8.00	-	6.25	-1.00	8.25	5.00	485	10.63	8.00	52.38	10.04	9.33	13.62	50.23	-	440
CR(N) 32-4 H	20	3	34.25	52.75	3.00	39.25	49.25	12.38	8.00	-	6.25	-1.00	10.00	5.00	480	11.50	9.00	52.13	13.39	12.13	16.54	53.03	-	590
CR(N)(E) 32-5-2 H	20	3	37.00	55.50	3.00	42.00	52.00	12.38	8.00	-	6.25	-1.00	10.00	5.00	487	11.50	9.00	55.00	13.39	12.13	16.54	55.78	-	597
CR(N)(E) 32-5 H	20	3	37.00	55.50	3.00	42.00	52.00	12.38	8.00	-	6.25	-1.00	10.00	5.00	487	11.50	9.00	55.00	13.39	12.13	16.54	55.78	-	597
CR(N) 32-6-2 H	25	3	39.75	62.13	3.00	44.75	54.25	12.38	8.00	-	7.00	-1.75	9.50	5.50	592	11.50	11.38	58.88	13.39	12.13	16.54	62.47	-	705
CR(N)(E) 32-6 H	25	3	39.75	62.13	3.00	44.75	54.25	12.38	8.00	-	7.00	-1.75	9.50	5.50	592	11.50	11.38	58.88	13.39	12.13	16.54	62.47	-	705
CR(N) 32-7-2 H	30	3	42.50	64.88	3.00	47.50	58.50	12.38	8.00	-	7.00	-1.75	11.00	5.50	625	11.50	11.38	63.13	13.39	12.13	16.54	65.22	-	740
CR(N)(E) 32-7 H	30	3	42.50	64.88	3.00	47.50	58.50	12.38	8.00	-	7.00	-1.75	11.00	5.50	625	11.50	11.38	63.13	13.39	12.13	16.54	65.22	-	740
CR(N)(E) 32-8-2 H	30	3	45.25	67.63	3.00	50.25	61.25	12.38	8.00	-	7.00	-1.75	11.00	5.50	638	11.50	11.38	65.88	13.39	12.13	16.54	67.97	-	754
CR(N) 32-8 H	40	3	45.25	68.50	3.00	50.25	61.25	15.00	-	13.13	7.00	-1.75	11.00	5.50	890	13.25	12.25	66.50	-	-	-	-	-	-
CR(N) 32-9-2 H	40	3	48.00	71.25	3.00	53.00	64.00	15.00	-	13.13	7.00	-1.75	11.00	5.50	907	13.25	12.25	69.25	-	-	-	-	-	-
CR(N) 32-9 H	40	3	48.00	71.25	3.00	53.00	64.00	15.00	-	13.13	7.00	-1.75	11.00	5.50	907	13.25	12.25	69.25	-	-	-	-	-	-
CR(N) 32-10-2 H	40	3	50.75	74.00	3.00	55.75	66.75	15.00	-	13.13	7.00	-1.75	11.00	5.50	914	13.25	12.25	72.00	-	-	-	-	-	-
CR(N) 32-10 H	40	3	50.75	74.00	3.00	55.75	66.75	15.00	-	13.13	7.00	-1.75	11.00	5.50	914	13.25	12.25	72.00	-	-	-	-	-	-
CR(N) 32-11-2 H	50	3	53.50	79.00	3.00	59.00	71.00	16.88	-	14.50	8.00	-2.75	12.00	6.25	976	13.25	12.25	75.75	-	-	-	-	-	-

Note: Terminal box is on top of ML motors (through 30 HP). Baldor motors have terminal box on the side (40 HP and larger). Reference D2 dimension. Weights are based on pump with TEFC motor.

\* Dimensions shown for three-phase MLE motors are for 460 V versions. See page 19 for 200-240 V, three-phase dimensions.

Dimensions and weights G10 (3" x 2" x 6")

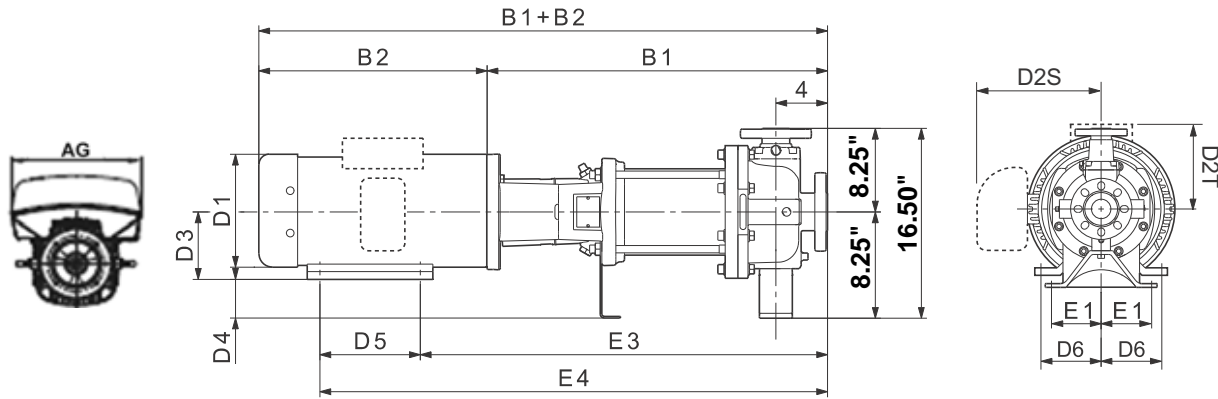

TM06 9699 1014 - TM06 1063 1514

Pump type	HP	PH	Dimensions [in] TEFC													Ship. wt. [lbs]	Dimensions [in] ODP			Dimensions [in] MLE*				Ship. wt. [lbs]
			B1	B1+B2	E1	E3	E4	D1	D2T	D2S	D3	D4	D5	D6	D1		D2	B1+B2	D1	D2	AG	B1+B2		
CR(N) 32-1-1 H	5	1	26.00	41.50	4.88	29.75	34.25	10.63	8.00	-	5.25	3.00	4.50	3.75	357	-	-	-	-	-	-	-	-	
		3	26.00	41.50	4.88	29.75	34.25	8.63	5.25	-	4.50	3.75	4.50	3.75	340	-	-	-	-	-	-	-	-	
CR(N)(E) 32-1 H	5	1	26.00	41.50	4.88	29.75	34.25	10.63	8.00	-	5.25	3.00	4.50	3.75	357	-	-	-	-	-	-	-	-	
		3	26.00	41.50	4.88	29.75	34.25	8.63	5.25	-	4.50	3.75	4.50	3.75	340	-	-	-	7.53	7.91	11.46	39.15	313	
CR(N) 32-2-2 H	7 1/2	1	29.25	44.75	4.88	33.75	39.25	10.25	7.63	-	5.25	3.00	5.50	4.25	376	-	-	-	-	-	-	-	-	
		3	29.25	44.75	4.88	33.75	39.25	8.63	5.25	-	5.25	3.00	5.50	4.25	355	-	-	-	7.53	7.91	11.46	43.62	346	
CR(N)(E) 32-2-1 H	7 1/2	1	29.25	44.75	4.88	33.75	39.25	10.25	7.63	-	5.25	3.00	5.50	4.25	376	-	-	-	-	-	-	-	-	
		3	29.25	44.75	4.88	33.75	39.25	8.63	5.25	-	5.25	3.00	5.50	4.25	355	-	-	-	7.53	7.91	11.46	43.62	346	
CR(N) 32-2 H	10	1	29.25	45.38	4.88	33.75	40.75	10.25	10.25	-	5.25	3.00	7.00	4.25	431	-	-	-	-	-	-	-	-	
		3	29.25	44.38	4.88	33.75	40.75	10.25	6.25	-	5.25	3.00	7.00	4.25	378	-	-	-	10.04	9.33	13.62	44.56	348	
CR(N)(E) 32-3-2 H	10	1	32.00	48.13	4.88	36.50	43.50	10.25	10.25	-	5.25	3.00	7.00	4.25	457	-	-	-	-	-	-	-	-	
		3	32.00	47.13	4.88	36.50	43.50	10.25	6.25	-	5.25	3.00	7.00	4.25	405	-	-	-	10.04	9.33	13.62	47.31	374	
CR(N) 32-3 H	15	3	31.50	50.00	4.88	36.50	44.75	12.38	8.00	-	6.25	2.00	8.25	5.00	483	10.63	8.00	49.63	10.04	9.33	13.62	47.48	438	
CR(N)(E) 32-4-2 H	15	3	34.25	52.75	4.88	39.25	47.50	12.38	8.00	-	6.25	2.00	8.25	5.00	490	10.63	8.00	52.38	10.04	9.33	13.62	50.23	445	
CR(N) 32-4 H	20	3	34.25	52.75	4.88	39.25	49.25	12.38	8.00	-	6.25	2.00	10.00	5.00	484	11.50	9.00	52.13	13.39	12.13	16.54	53.03	595	
CR(N)(E) 32-5-2 H	20	3	37.00	55.50	4.88	42.00	52.00	12.38	8.00	-	6.25	2.00	10.00	5.00	491	11.50	9.00	55.00	13.39	12.13	16.54	55.78	601	
CR(N)(E) 32-5 H	20	3	37.00	55.50	4.88	42.00	52.00	12.38	8.00	-	6.25	2.00	10.00	5.00	491	11.50	9.00	55.00	13.39	12.13	16.54	55.78	601	
CR(N) 32-6-2 H	25	3	39.75	62.13	4.88	44.75	54.25	12.38	8.00	-	7.00	1.25	9.50	5.50	597	11.50	11.38	58.88	13.39	12.13	16.54	62.47	709	
CR(N)(E) 32-6 H	25	3	39.75	62.13	4.88	44.75	54.25	12.38	8.00	-	7.00	1.25	9.50	5.50	597	11.50	11.38	58.88	13.39	12.13	16.54	62.47	709	
CR(N) 32-7-2 H	30	3	42.50	64.88	4.88	47.50	58.50	12.38	8.00	-	7.00	1.25	11.00	5.50	630	11.50	11.38	63.13	13.39	12.13	16.54	65.22	745	
CR(N)(E) 32-7 H	30	3	42.50	64.88	4.88	47.50	58.50	12.38	8.00	-	7.00	1.25	11.00	5.50	630	11.50	11.38	63.13	13.39	12.13	16.54	65.22	745	
CR(N)(E) 32-8-2 H	30	3	45.25	67.63	4.88	50.25	61.25	12.38	8.00	-	7.00	1.25	11.00	5.50	643	11.50	11.38	65.88	13.39	12.13	16.54	67.97	758	
CR(N) 32-8 H	40	3	45.25	68.50	4.88	50.25	61.25	15.00	-	13.13	7.00	1.25	11.00	5.50	894	13.25	12.25	66.50	-	-	-	-	-	
CR(N) 32-9-2 H	40	3	48.00	71.25	4.88	53.00	64.00	15.00	-	13.13	7.00	1.25	11.00	5.50	912	13.25	12.25	69.25	-	-	-	-	-	
CR(N) 32-9 H	40	3	48.00	71.25	4.88	53.00	64.00	15.00	-	13.13	7.00	1.25	11.00	5.50	912	13.25	12.25	69.25	-	-	-	-	-	
CR(N) 32-10-2 H	40	3	50.75	74.00	4.88	55.75	66.75	15.00	-	13.13	7.00	1.25	11.00	5.50	918	13.25	12.25	72.00	-	-	-	-	-	
CR(N) 32-10 H	40	3	50.75	74.00	4.88	55.75	66.75	15.00	-	13.13	7.00	1.25	11.00	5.50	918	13.25	12.25	72.00	-	-	-	-	-	
CR(N) 32-11-2 H	50	3	53.50	79.00	4.88	59.00	71.00	16.88	-	14.50	8.00	0.25	12.00	6.25	980	13.25	12.25	75.75	-	-	-	-	-	

Note: Terminal box is on top of ML motors (through 30 HP). Baldor motors have terminal box on the side (40 HP and larger). Reference D2 dimension. Weights are based on pump with TEFC motor.

\* Dimensions shown for three-phase MLE motors are for 460 V versions. See page 19 for 200-240 V, three-phase dimensions.

CR, CRE, CRN, CRNE 32 H GC/G10/G60

Dimensions and weights G60 (3" x 2" x 8", 3" x 2" x 10")

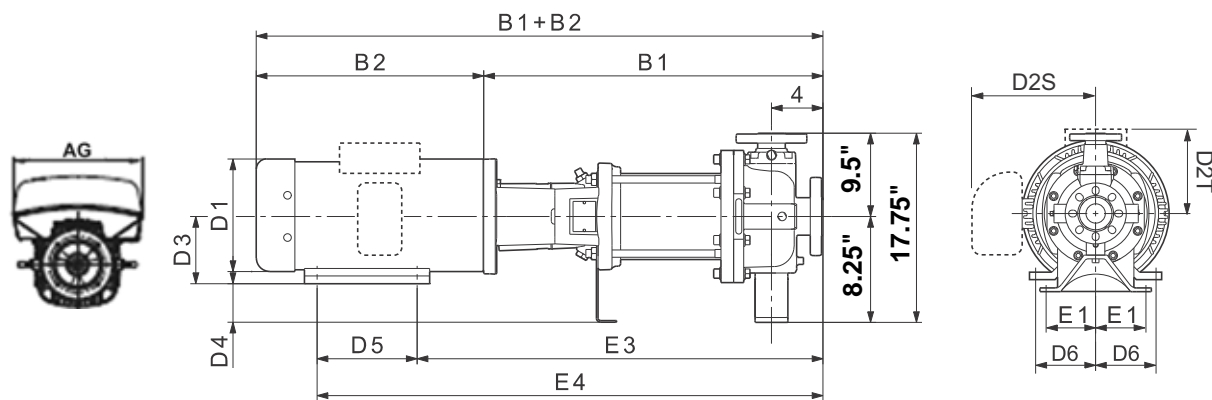

TM06 9699 1014 - TM06 1063 1514

Pump type	HP	PH	Dimensions [in] TEFC											Ship. wt. [lbs]	Dimensions [in] ODP			Dimensions [in] MLE*				Ship. wt. [lbs]		
			B1	B1+B2	E1	E3	E4	D1	D2T	D2S	D3	D4	D5		D6	D1	D2	B1+B2	D1	D2	AG		B1+B2	
CR(N) 32-1-1 H	5	1	26.00	41.50	4.88	29.75	34.25	10.63	8.00	-	5.25	3.00	4.50	3.75	419	-	-	-	-	-	-	-	-	-
		3	26.00	41.50	4.88	29.75	34.25	8.63	5.25	-	4.50	3.75	4.50	3.75	401	-	-	-	-	-	-	-	-	-
CR(N)(E) 32-1 H	5	1	26.00	41.50	4.88	29.75	34.25	10.63	8.00	-	5.25	3.00	4.50	3.75	419	-	-	-	-	-	-	-	-	-
		3	26.00	41.50	4.88	29.75	34.25	8.63	5.25	-	4.50	3.75	4.50	3.75	401	-	-	-	7.53	7.91	11.46	39.15	-	375
CR(N) 32-2-2 H	7 1/2	1	29.25	44.75	4.88	33.75	39.25	10.25	7.63	-	5.25	3.00	5.50	4.25	437	-	-	-	-	-	-	-	-	-
		3	29.25	44.75	4.88	33.75	39.25	8.63	5.25	-	5.25	3.00	5.50	4.25	417	-	-	-	7.53	7.91	11.46	43.62	-	407
CR(N)(E) 32-2-1 H	7 1/2	1	29.25	44.75	4.88	33.75	39.25	10.25	7.63	-	5.25	3.00	5.50	4.25	437	-	-	-	-	-	-	-	-	-
		3	29.25	44.75	4.88	33.75	39.25	8.63	5.25	-	5.25	3.00	5.50	4.25	417	-	-	-	7.53	7.91	11.46	43.62	-	407
CR(N) 32-2 H	10	1	29.25	45.38	4.88	33.75	40.75	10.25	10.25	-	5.25	3.00	7.00	4.25	492	-	-	-	-	-	-	-	-	-
		3	29.25	44.38	4.88	33.75	40.75	10.25	6.25	-	5.25	3.00	7.00	4.25	440	-	-	-	10.04	9.33	13.62	44.56	-	409
CR(N)(E) 32-3-2 H	10	1	32.00	48.13	4.88	36.50	43.50	10.25	10.25	-	5.25	3.00	7.00	4.25	499	-	-	-	-	-	-	-	-	-
		3	32.00	47.13	4.88	36.50	43.50	10.25	6.25	-	5.25	3.00	7.00	4.25	447	-	-	-	10.04	9.33	13.62	47.31	-	416
CR(N) 32-3 H	15	3	31.50	50.00	4.88	36.50	44.75	12.38	8.00	-	6.25	2.00	8.25	5.00	525	10.63	8.00	49.63	10.04	9.33	13.62	47.48	-	480
CR(N)(E) 32-4-2 H	15	3	34.25	52.75	4.88	39.25	47.50	12.38	8.00	-	6.25	2.00	8.25	5.00	532	10.63	8.00	52.38	10.04	9.33	13.62	50.23	-	486
CR(N) 32-4 H	20	3	34.25	52.75	4.88	39.25	49.25	12.38	8.00	-	6.25	2.00	10.00	5.00	526	11.50	9.00	52.13	13.39	12.13	16.54	53.03	-	636
CR(N)(E) 32-5-2 H	20	3	37.00	55.50	4.88	42.00	52.00	12.38	8.00	-	6.25	2.00	10.00	5.00	533	11.50	9.00	55.00	13.39	12.13	16.54	55.78	-	643
CR(N)(E) 32-5 H	20	3	37.00	55.50	4.88	42.00	52.00	12.38	8.00	-	6.25	2.00	10.00	5.00	533	11.50	9.00	55.00	13.39	12.13	16.54	55.78	-	643
CR(N) 32-6-2 H	25	3	39.75	62.13	4.88	44.75	54.25	12.38	8.00	-	7.00	1.25	9.50	5.50	597	11.50	11.38	58.88	13.39	12.13	16.54	62.47	-	709
CR(N)(E) 32-6 H	25	3	39.75	62.13	4.88	44.75	54.25	12.38	8.00	-	7.00	1.25	9.50	5.50	597	11.50	11.38	58.88	13.39	12.13	16.54	62.47	-	709
CR(N) 32-7-2 H	30	3	42.50	64.88	4.88	47.50	58.50	12.38	8.00	-	7.00	1.25	11.00	5.50	630	11.50	11.38	63.13	13.39	12.13	16.54	65.22	-	745
CR(N)(E) 32-7 H	30	3	42.50	64.88	4.88	47.50	58.50	12.38	8.00	-	7.00	1.25	11.00	5.50	630	11.50	11.38	63.13	13.39	12.13	16.54	65.22	-	745
CR(N)(E) 32-8-2 H	30	3	45.25	67.63	4.88	50.25	61.25	12.38	8.00	-	7.00	1.25	11.00	5.50	645	11.50	11.38	65.88	13.39	12.13	16.54	67.97	-	760
CR(N) 32-8 H	40	3	45.25	68.50	4.88	50.25	61.25	15.00	-	13.13	7.00	1.25	11.00	5.50	896	13.25	12.25	66.50	-	-	-	-	-	-
CR(N) 32-9-2 H	40	3	48.00	71.25	4.88	53.00	64.00	15.00	-	13.13	7.00	1.25	11.00	5.50	912	13.25	12.25	69.25	-	-	-	-	-	-
CR(N) 32-9 H	40	3	48.00	71.25	4.88	53.00	64.00	15.00	-	13.13	7.00	1.25	11.00	5.50	912	13.25	12.25	69.25	-	-	-	-	-	-
CR(N) 32-10-2 H	40	3	50.75	74.00	4.88	55.75	66.75	15.00	-	13.13	7.00	1.25	11.00	5.50	918	13.25	12.25	72.00	-	-	-	-	-	-
CR(N) 32-10 H	40	3	50.75	74.00	4.88	55.75	66.75	15.00	-	13.13	7.00	1.25	11.00	5.50	918	13.25	12.25	72.00	-	-	-	-	-	-
CR(N) 32-11-2 H	50	3	53.50	79.00	4.88	59.00	71.00	16.88	-	14.50	8.00	0.25	12.00	6.25	980	13.25	12.25	75.75	-	-	-	-	-	-

Note: Terminal box is on top of ML motors (through 30 HP). Baldor motors have terminal box on the side (40 HP and larger). Reference D2 dimension. Weights are based on pump with TEFC motor.

\* Dimensions shown for three-phase MLE motors are for 460 V versions. See page 19 for 200-240 V, three-phase dimensions.

**CR, CRE, CRN, CRNE 45 H G33**

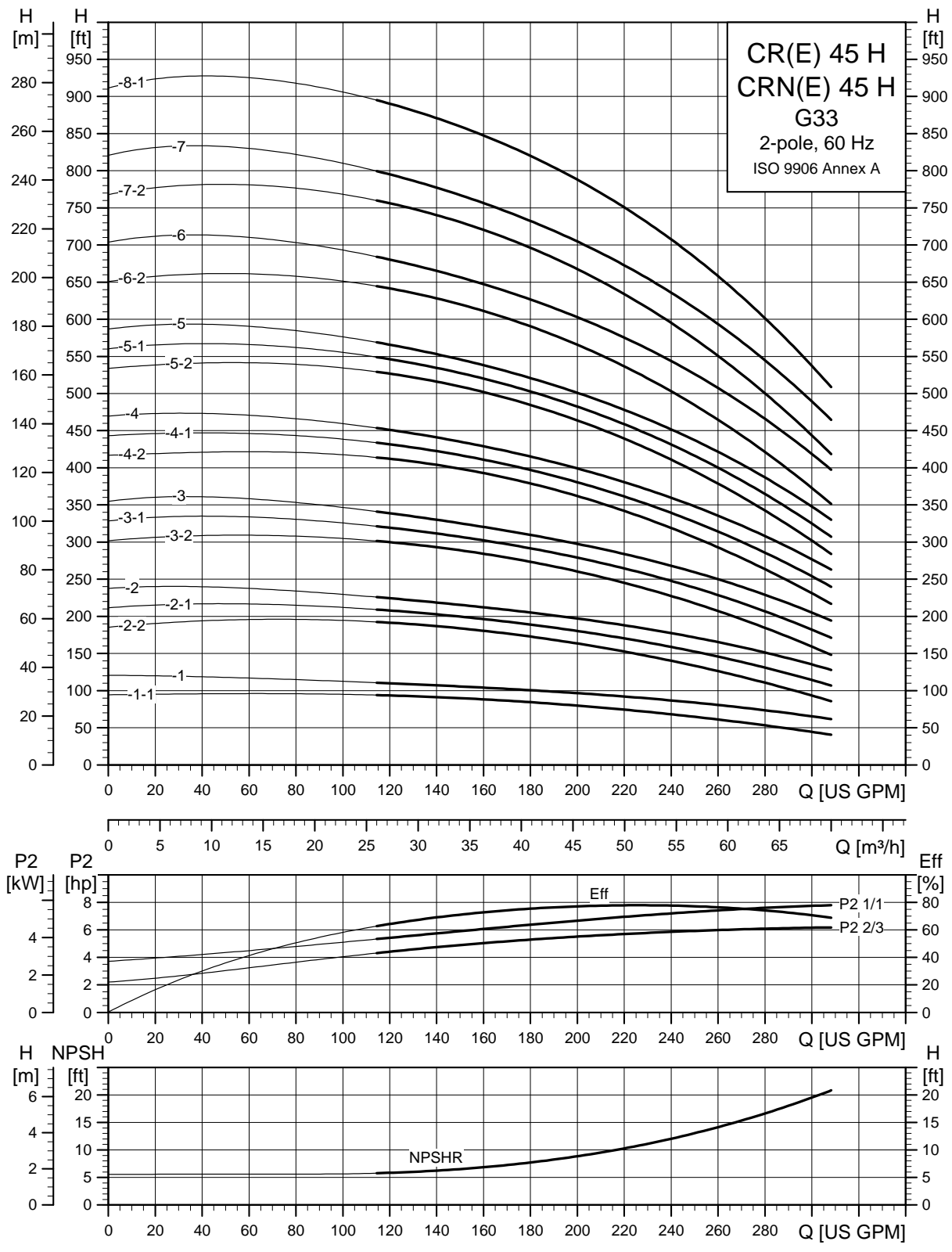

TM04 6298 09/12

Dimensions and weights G33 (3" x 3")

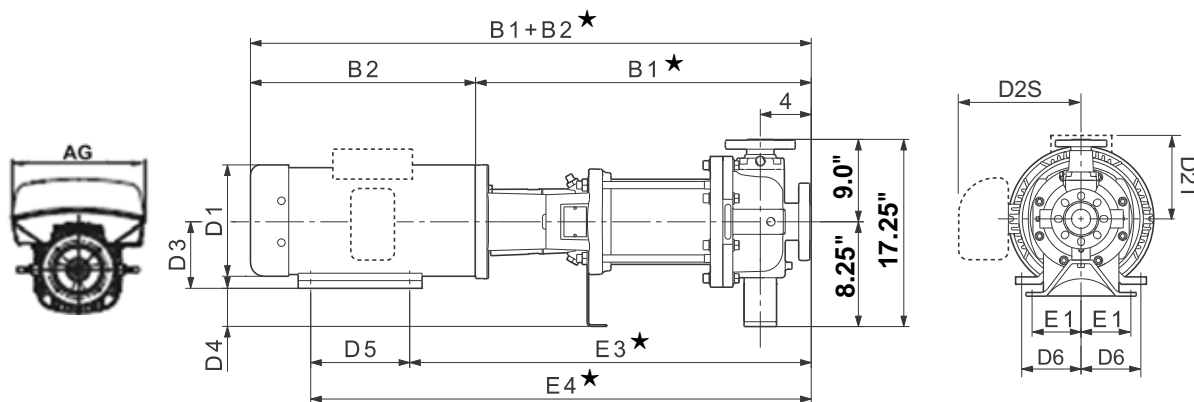

TM06 9699 1014 - TM06 1063 1514

Pump type	HP	PH	Dimensions [in] TEFC											Ship. wt. [lbs]	Dimensions [in] ODP			Dimensions [in] MLE*				Ship. wt. [lbs]	
			B1 ★	B1+ B2 ★	E1	E3 ★	E4 ★	D1	D2T	D2S	D3	D4	D5		D6	D1	D2	B1+ B2 ★	D1	D2	AG		B1+ B2 ★
CR(N)(E) 45-1-1 H 7 1/2	1	3	26.13	41.63	4.88	30.63	36.13	10.25	7.63	-	5.25	3.00	5.50	4.25	301	-	-	-	-	-	-	-	-
			26.13	41.63	4.88	30.63	36.13	8.63	5.25	-	5.25	3.00	5.50	4.25	280	-	-	-	7.53	7.91	11.46	40.50	271
CR(N)(E) 45-1 H	10	3	26.13	42.13	4.88	30.63	37.63	10.25	10.25	-	5.25	3.00	7.00	4.25	356	-	-	-	-	-	-	-	-
			26.13	41.25	4.88	30.63	37.63	10.25	6.25	-	5.25	3.00	7.00	4.25	304	-	-	-	10.04	9.33	13.62	41.44	273
CR(N)(E) 45-2-2 H	15	3	28.75	47.25	4.88	33.75	42.00	12.38	8.00	-	6.25	2.00	8.25	5.00	389	10.63	8.00	46.88	10.04	9.33	13.62	44.73	343
CR(N) 45-2-1 H	15	3	28.75	47.25	4.88	33.75	42.00	12.38	8.00	-	6.25	2.00	8.25	5.00	389	10.63	8.00	46.88	10.04	9.33	13.62	44.73	343
CR(N)(E) 45-2 H	15	3	28.75	47.25	4.88	33.75	42.00	12.38	8.00	-	6.25	2.00	8.25	5.00	389	10.63	8.00	46.88	10.04	9.33	13.62	44.73	343
CR(N)(E) 45-3-2 H	20	3	31.88	50.38	4.88	36.88	46.88	12.38	8.00	-	6.25	2.00	10.00	5.00	410	11.50	9.00	49.88	13.39	12.13	16.54	50.66	520
CR(N) 45-3-1 H	25	3	31.88	54.25	4.88	36.88	46.38	12.38	8.00	-	7.00	1.25	9.50	5.50	438	11.50	11.38	51.00	13.39	12.13	16.54	54.60	551
CR(N)(E) 45-3 H	25	3	31.88	54.25	4.88	36.88	46.38	12.38	8.00	-	7.00	1.25	9.50	5.50	438	11.50	11.38	51.00	13.39	12.13	16.54	54.60	551
CR(N)(E) 45-4-2 H	30	3	35.00	57.38	4.88	40.00	51.00	12.38	8.00	-	7.00	1.25	11.00	5.50	542	11.50	11.38	55.63	13.39	12.13	16.54	57.72	657
CR(N) 45-4-1 H	30	3	35.00	57.38	4.88	40.00	51.00	12.38	8.00	-	7.00	1.25	11.00	5.50	542	11.50	11.38	55.63	13.39	12.13	16.54	57.72	657
CR(N)(E) 45-4 H	30	3	35.00	57.38	4.88	40.00	51.00	12.38	8.00	-	7.00	1.25	11.00	5.50	542	11.50	11.38	55.63	13.39	12.13	16.54	57.72	657
CR(N) 45-5-2 H	40	3	38.13	61.38	4.88	43.13	54.13	15.00	-	13.13	7.00	1.25	11.00	5.50	802	13.25	12.25	59.38	-	-	-	-	-
CR(N) 45-5-1 H	40	3	38.13	61.38	4.88	43.13	54.13	15.00	-	13.13	7.00	1.25	11.00	5.50	802	13.25	12.25	59.38	-	-	-	-	-
CR(N) 45-5 H	40	3	38.13	61.38	4.88	43.13	54.13	15.00	-	13.13	7.00	1.25	11.00	5.50	802	13.25	12.25	59.38	-	-	-	-	-
CR(N) 45-6-2 H	50	3	41.38	66.75	4.88	46.88	58.88	16.88	-	14.50	8.00	0.25	12.00	6.25	870	13.25	12.25	63.50	-	-	-	-	-
CR(N) 45-6 H	50	3	41.38	66.75	4.88	46.88	58.88	16.88	-	14.50	8.00	0.25	12.00	6.25	870	13.25	12.25	63.50	-	-	-	-	-
CR(N) 45-7-2 H	50	3	44.50	69.88	4.88	50.00	62.00	16.88	-	14.50	8.00	0.25	12.00	6.25	888	13.25	12.25	66.63	-	-	-	-	-
CR(N) 45-7 H	60	3	44.50	71.88	4.88	50.63	62.88	16.88	-	14.63	9.00	-0.75	12.25	7.00	1162	15.13	13.25	68.50	-	-	-	-	-
CR(N) 45-8-1 H	60	3	47.63	75.00	4.88	53.75	66.00	16.88	-	14.63	9.00	-0.75	12.25	7.00	1173	15.13	13.25	71.75	-	-	-	-	-

Note: Terminal box is on top of ML motors (through 30 HP). Baldor motors have terminal box on the side (40 HP and larger). Reference D2 dimension. Weights are based on pump with TEFC motor.

\* Dimensions shown for three-phase MLE motors are for 460 V versions. See page 19 for 200-240 V, three-phase dimensions.

★ Add 0.67 inches for CRN-H dimensions.

**CR, CRE, CRN, CRNE 45 H GB/G20/G50**

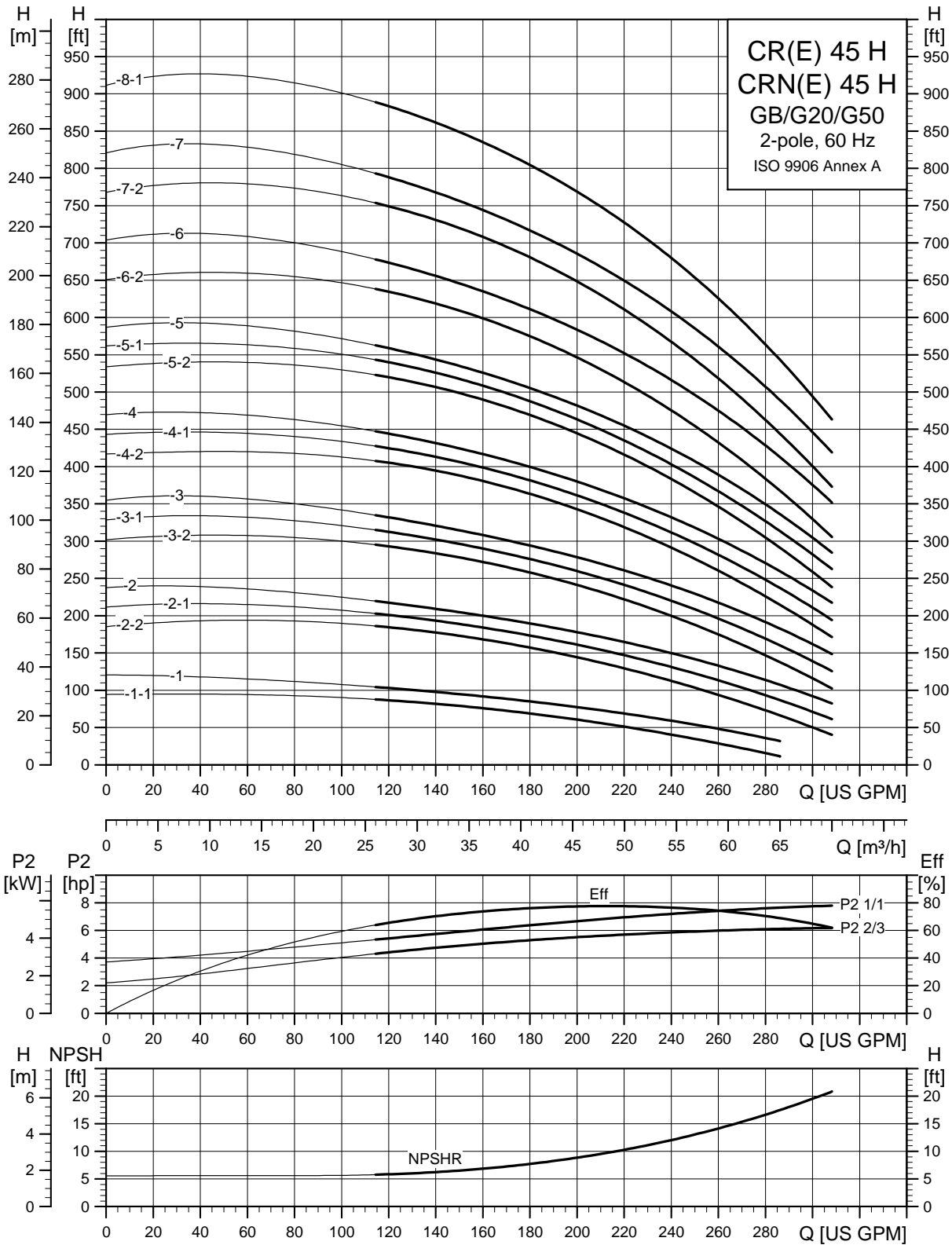

TM04 6296 0912

Dimensions and weights GB (3" x 1.5" x 6", 3" x 1.5" x 8")

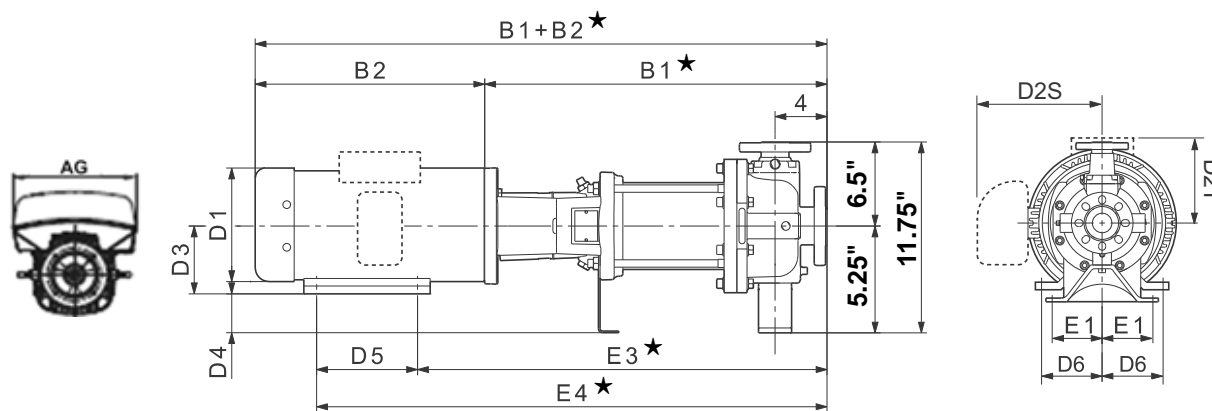

TM06 9699 1014 - TM06 1063 1514

Pump type	HP	PH	Dimensions [in] TEFC											Ship. wt. [lbs]	Dimensions [in] ODP			Dimensions [in] MLE*				Ship. wt. [lbs]	
			B1*	B1+B2*	E1	E3*	E4*	D1	D2T	D2S	D3	D4	D5		D6	D1	D2	B1+B2*	D1	D2	AG		B1+B2*
CR(N)(E) 45-1-1 H 7 1/2	1	3	27.38	42.88	3.00	31.88	37.38	10.25	7.63	-	5.25	0.00	5.50	4.25	301	-	-	-	-	-	-	-	-
			27.38	42.88	3.00	31.88	37.38	8.63	5.25	-	5.25	0.00	5.50	4.25	280	-	-	-	7.53	7.91	11.46	41.75	271
CR(N)(E) 45-1 H	10	3	27.38	43.38	3.00	31.88	38.88	10.25	10.25	-	5.25	0.00	7.00	4.25	356	-	-	-	-	-	-	-	-
			27.38	42.50	3.00	31.88	38.88	10.25	6.25	-	5.25	0.00	7.00	4.25	304	-	-	-	10.04	9.33	13.62	42.69	273
CR(N)(E) 45-2-2 H	15	3	30.00	48.50	3.00	35.00	43.25	12.38	8.00	-	6.25	-1.00	8.25	5.00	389	10.63	8.00	48.13	10.04	9.33	13.62	45.98	343
CR(N) 45-2-1 H	15	3	30.00	48.50	3.00	35.00	43.25	12.38	8.00	-	6.25	-1.00	8.25	5.00	389	10.63	8.00	48.13	10.04	9.33	13.62	45.98	343
CR(N)(E) 45-2 H	15	3	30.00	48.50	3.00	35.00	43.25	12.38	8.00	-	6.25	-1.00	8.25	5.00	389	10.63	8.00	48.13	10.04	9.33	13.62	45.98	343
CR(N)(E) 45-3-2 H	20	3	33.13	51.63	3.00	38.13	48.13	12.38	8.00	-	6.25	-1.00	10.00	5.00	410	11.50	9.00	51.13	13.39	12.13	16.54	51.91	520
CR(N) 45-3-1 H	25	3	33.13	55.50	3.00	38.13	47.63	12.38	8.00	-	7.00	-1.75	9.50	5.50	438	11.50	11.38	52.25	13.39	12.13	16.54	55.85	551
CR(N)(E) 45-3 H	25	3	33.13	55.50	3.00	38.13	47.63	12.38	8.00	-	7.00	-1.75	9.50	5.50	440	11.50	11.38	52.25	13.39	12.13	16.54	55.85	553
CR(N)(E) 45-4-2 H	30	3	36.25	58.63	3.00	41.25	52.25	12.38	8.00	-	7.00	-1.75	11.00	5.50	542	11.50	11.38	56.88	13.39	12.13	16.54	58.97	657
CR(N) 45-4-1 H	30	3	36.25	58.63	3.00	41.25	52.25	12.38	8.00	-	7.00	-1.75	11.00	5.50	542	11.50	11.38	56.88	13.39	12.13	16.54	58.97	657
CR(N)(E) 45-4 H	30	3	36.25	58.63	3.00	41.25	52.25	12.38	8.00	-	7.00	-1.75	11.00	5.50	542	11.50	11.38	56.88	13.39	12.13	16.54	58.97	657
CR(N) 45-5-2 H	40	3	39.50	62.63	3.00	44.50	55.50	15.00	-	13.13	7.00	-1.75	11.00	5.50	802	13.25	12.25	60.63	-	-	-	-	-
CR(N) 45-5-1 H	40	3	39.50	62.63	3.00	44.50	55.50	15.00	-	13.13	7.00	-1.75	11.00	5.50	802	13.25	12.25	60.63	-	-	-	-	-
CR(N) 45-5 H	40	3	39.50	62.63	3.00	44.50	55.50	15.00	-	13.13	7.00	-1.75	11.00	5.50	802	13.25	12.25	60.63	-	-	-	-	-
CR(N) 45-6-2 H	50	3	42.63	68.00	3.00	48.13	60.13	16.88	-	14.50	8.00	-2.75	12.00	6.25	870	13.25	12.25	64.75	-	-	-	-	-
CR(N) 45-6 H	50	3	42.63	68.00	3.00	48.13	60.13	16.88	-	14.50	8.00	-2.75	12.00	6.25	870	13.25	12.25	64.75	-	-	-	-	-
CR(N) 45-7-2 H	50	3	45.75	71.13	3.00	51.25	63.25	16.88	-	14.50	8.00	-2.75	12.00	6.25	888	13.25	12.25	67.88	-	-	-	-	-
CR(N) 45-7 H	60	3	45.75	73.13	3.00	51.88	64.13	16.88	-	14.63	9.00	-3.75	12.25	7.00	1164	15.13	13.25	69.75	-	-	-	-	-
CR(N) 45-8-1 H	60	3	48.88	76.25	3.00	55.00	67.25	16.88	-	14.63	9.00	-3.75	12.25	7.00	1173	15.13	13.25	73.00	-	-	-	-	-

Note: Terminal box is on top of ML motors (through 30 HP). Baldor motors have terminal box on the side (40 HP and larger). Reference D2 dimension. Weights are based on pump with TEFC motor.

\* Dimensions shown for three-phase MLE motors are for 460 V versions. See page 19 for 200-240 V, three-phase dimensions.

★ Add 0.16 inches for CRN-H dimensions.

Dimensions and weights G20 (3" x 1.5" x 13")

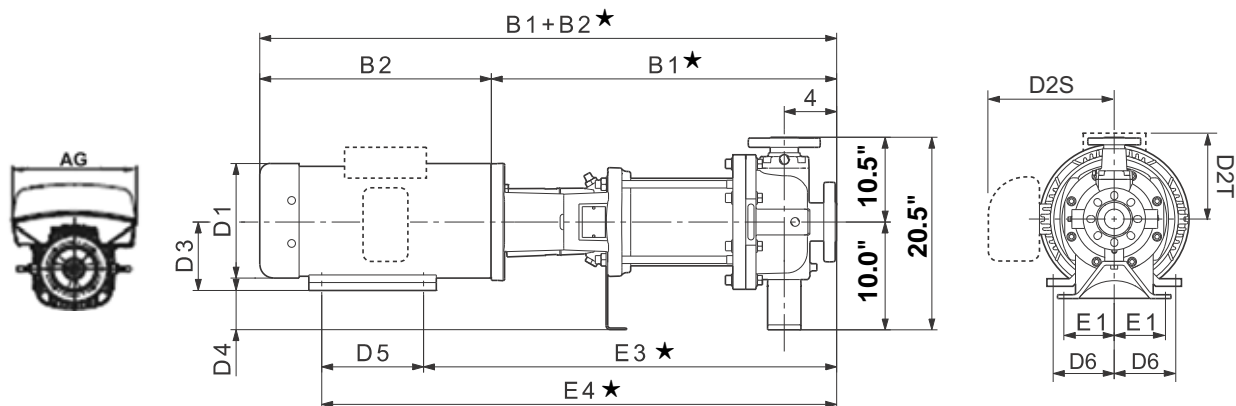

TM06 9699 1014 - TM06 1063 1514

Pump type	HP	PH	Dimensions [in] TEFC											Ship. wt. [lbs]	Dimensions [in] ODP			Dimensions [in] MLE*				Ship. wt. [lbs]						
			B1 ★	B1+ B2 ★	E1	E3 ★	E4 ★	D1	D2T	D2S	D3	D4	D5		D6	D1	D2	B1+ B2 ★	D1	D2	AG		B1+ B2 ★					
CR(N)(E) 45-1-1 H	7 1/2	1	26.13	41.63	4.88	30.63	36.13	10.25	7.63	-	5.25	4.75	5.50	4.25	442	-	-	-	-	-	-	-	-	-	-	-	-	-
		3	26.13	41.63	4.88	30.63	36.13	8.63	5.25	-	5.25	4.75	5.50	4.25	421	-	-	-	7.53	7.91	11.46	40.50	-	-	-	-	-	412
CR(N)(E) 45-1 H	10	1	26.13	42.13	4.88	30.63	37.63	10.25	10.25	-	5.25	4.75	7.00	4.25	497	-	-	-	-	-	-	-	-	-	-	-	-	-
		3	26.13	41.25	4.88	30.63	37.63	10.25	6.25	-	5.25	4.75	7.00	4.25	444	-	-	-	10.04	9.33	13.62	41.44	-	-	-	-	-	414
CR(N)(E) 45-2 H	15	3	28.75	47.25	4.88	33.75	42.00	12.38	8.00	-	6.25	3.75	8.25	5.00	532	10.63	8.00	46.88	10.04	9.33	13.62	44.73	-	-	-	-	-	486
CR(N) 45-2-1 H	15	3	28.75	47.25	4.88	33.75	42.00	12.38	8.00	-	6.25	3.75	8.25	5.00	532	10.63	8.00	46.88	10.04	9.33	13.62	44.73	-	-	-	-	-	486
CR(N)(E) 45-2 H	15	3	28.75	47.25	4.88	33.75	42.00	12.38	8.00	-	6.25	3.75	8.25	5.00	532	10.63	8.00	46.88	10.04	9.33	13.62	44.73	-	-	-	-	-	486
CR(N)(E) 45-3-2 H	20	3	31.88	50.38	4.88	36.88	46.88	12.38	8.00	-	6.25	3.75	10.00	5.00	533	11.50	9.00	49.88	13.39	12.13	16.54	50.66	-	-	-	-	-	643
CR(N) 45-3-1 H	25	3	31.88	54.25	4.88	36.88	46.38	12.38	8.00	-	7.00	3.00	9.50	5.50	561	11.50	11.38	51.00	13.39	12.13	16.54	54.60	-	-	-	-	-	674
CR(N)(E) 45-3 H	25	3	31.88	54.25	4.88	36.88	46.38	12.38	8.00	-	7.00	3.00	9.50	5.50	561	11.50	11.38	51.00	13.39	12.13	16.54	54.60	-	-	-	-	-	674
CR(N)(E) 45-4-2 H	30	3	35.00	57.38	4.88	40.00	51.00	12.38	8.00	-	7.00	3.00	11.00	5.50	623	11.50	11.38	55.63	13.39	12.13	16.54	57.72	-	-	-	-	-	738
CR(N) 45-4-1 H	30	3	35.00	57.38	4.88	40.00	51.00	12.38	8.00	-	7.00	3.00	11.00	5.50	623	11.50	11.38	55.63	13.39	12.13	16.54	57.72	-	-	-	-	-	738
CR(N)(E) 45-4 H	30	3	35.00	57.38	4.88	40.00	51.00	12.38	8.00	-	7.00	3.00	11.00	5.50	623	11.50	11.38	55.63	13.39	12.13	16.54	57.72	-	-	-	-	-	738
CR(N) 45-5-2 H	40	3	38.13	61.38	4.88	43.13	54.13	15.00	-	13.13	7.00	3.00	11.00	5.50	887	13.25	12.25	59.38	-	-	-	-	-	-	-	-	-	-
CR(N) 45-5-1 H	40	3	38.13	61.38	4.88	43.13	54.13	15.00	-	13.13	7.00	3.00	11.00	5.50	887	13.25	12.25	59.38	-	-	-	-	-	-	-	-	-	-
CR(N) 45-5 H	40	3	38.13	61.38	4.88	43.13	54.13	15.00	-	13.13	7.00	3.00	11.00	5.50	887	13.25	12.25	59.38	-	-	-	-	-	-	-	-	-	-
CR(N) 45-6-2 H	50	3	41.38	66.75	4.88	46.88	58.88	16.88	-	14.50	8.00	2.00	12.00	6.25	956	13.25	12.25	63.50	-	-	-	-	-	-	-	-	-	-
CR(N) 45-6 H	50	3	41.38	66.75	4.88	46.88	58.88	16.88	-	14.50	8.00	2.00	12.00	6.25	956	13.25	12.25	63.50	-	-	-	-	-	-	-	-	-	-
CR(N) 45-7-2 H	50	3	44.50	69.88	4.88	50.00	62.00	16.88	-	14.50	8.00	2.00	12.00	6.25	976	13.25	12.25	66.63	-	-	-	-	-	-	-	-	-	-
CR(N) 45-7 H	60	3	44.50	71.88	4.88	50.63	62.88	16.88	-	14.63	9.00	1.00	12.25	7.00	1250	15.13	13.25	68.50	-	-	-	-	-	-	-	-	-	-
CR(N) 45-8-1 H	60	3	47.63	75.00	4.88	53.75	66.00	16.88	-	14.63	9.00	1.00	12.25	7.00	1259	15.13	13.25	71.75	-	-	-	-	-	-	-	-	-	-

Note: Terminal box is on top of ML motors (through 30 HP). Baldor motors have terminal box on the side (40 HP and larger). Reference D2 dimension. Weights are based on pump with TEFC motor.

\* Dimensions shown for three-phase MLE motors are for 460 V versions. See page 19 for 200-240 V, three-phase dimensions.

★ Add 0.67 inches for CRN-H dimensions.

Dimensions and weights G50 (3" x 1.5" x 8", 3" x 1.5" x 10")

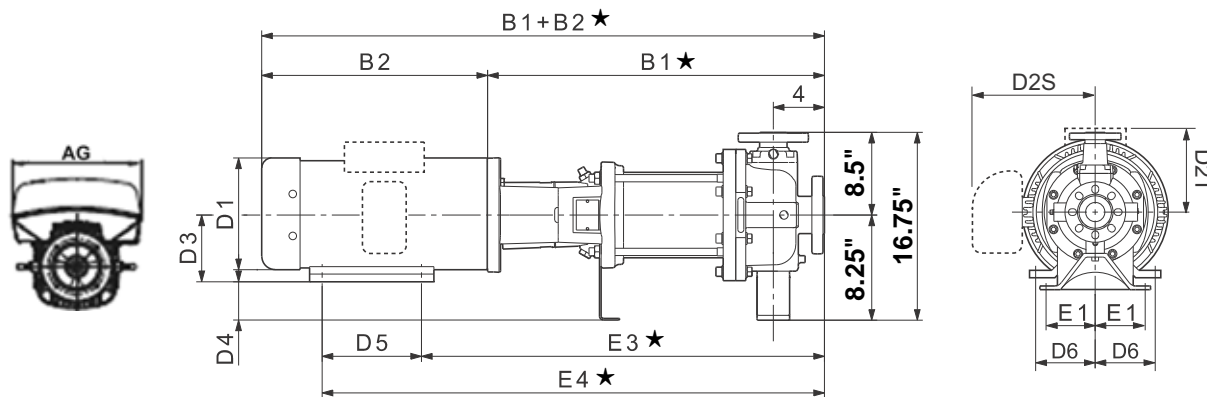

TM06 9699 1014 - TM06 1063 1514

Pump type	HP	PH	Dimensions [in] TEFC											Ship. wt. [lbs]	Dimensions [in] ODP			Dimensions [in] MLE*				Ship. wt. [lbs]	
			B1★	B1+B2★	E1	E3★	E4★	D1	D2T	D2S	D3	D4	D5		D6	D1	D2	B1+B2★	D1	D2	AG		B1+B2★
CR(N)(E) 45-1-1 H 7 1/2	1	3	26.13	41.63	4.88	30.63	36.13	10.25	7.63	-	5.25	3.00	5.50	4.25	448	-	-	-	-	-	-	-	-
			26.13	41.63	4.88	30.63	36.13	8.63	5.25	-	5.25	3.00	5.50	4.25	428	-	-	-	7.53	7.91	11.46	40.50	418
CR(N)(E) 45-1 H 10	1	3	26.13	42.13	4.88	30.63	37.63	10.25	10.25	-	5.25	3.00	7.00	4.25	503	-	-	-	-	-	-	-	-
			26.13	41.25	4.88	30.63	37.63	10.25	6.25	-	5.25	3.00	7.00	4.25	451	-	-	-	10.04	9.33	13.62	41.44	420
CR(N)(E) 45-2-2 H 15	3	3	28.75	47.25	4.88	33.75	42.00	12.38	8.00	-	6.25	2.00	8.25	5.00	538	10.63	8.00	46.88	10.04	9.33	13.62	44.73	493
CR(N) 45-2-1 H 15	3	3	28.75	47.25	4.88	33.75	42.00	12.38	8.00	-	6.25	2.00	8.25	5.00	538	10.63	8.00	46.88	10.04	9.33	13.62	44.73	493
CR(N)(E) 45-2 H 15	3	3	28.75	47.25	4.88	33.75	42.00	12.38	8.00	-	6.25	2.00	8.25	5.00	538	10.63	8.00	46.88	10.04	9.33	13.62	44.73	493
CR(N)(E) 45-3-2 H 20	3	3	31.88	50.38	4.88	36.88	46.88	12.38	8.00	-	6.25	2.00	10.00	5.00	542	11.50	9.00	49.88	13.39	12.13	16.54	50.66	652
CR(N) 45-3-1 H 25	3	3	31.88	54.25	4.88	36.88	46.38	12.38	8.00	-	7.00	1.25	9.50	5.50	570	11.50	11.38	51.00	13.39	12.13	16.54	54.60	683
CR(N)(E) 45-3 H 25	3	3	31.88	54.25	4.88	36.88	46.38	12.38	8.00	-	7.00	1.25	9.50	5.50	570	11.50	11.38	51.00	13.39	12.13	16.54	54.60	683
CR(N)(E) 45-4-2 H 30	3	3	35.00	57.38	4.88	40.00	51.00	12.38	8.00	-	7.00	1.25	11.00	5.50	630	11.50	11.38	55.63	13.39	12.13	16.54	57.72	745
CR(N) 45-4-1 H 30	3	3	35.00	57.38	4.88	40.00	51.00	12.38	8.00	-	7.00	1.25	11.00	5.50	630	11.50	11.38	55.63	13.39	12.13	16.54	57.72	745
CR(N)(E) 45-4 H 30	3	3	35.00	57.38	4.88	40.00	51.00	12.38	8.00	-	7.00	1.25	11.00	5.50	630	11.50	11.38	55.63	13.39	12.13	16.54	57.72	745
CR(N) 45-5-2 H 40	3	3	38.13	61.38	4.88	43.13	54.13	15.00	-	13.13	7.00	1.25	11.00	5.50	894	13.25	12.25	59.38	-	-	-	-	-
CR(N) 45-5-1 H 40	3	3	38.13	61.38	4.88	43.13	54.13	15.00	-	13.13	7.00	1.25	11.00	5.50	894	13.25	12.25	59.38	-	-	-	-	-
CR(N) 45-5 H 40	3	3	38.13	61.38	4.88	43.13	54.13	15.00	-	13.13	7.00	1.25	11.00	5.50	894	13.25	12.25	59.38	-	-	-	-	-
CR(N) 45-6-2 H 50	3	3	41.38	66.75	4.88	46.88	58.88	16.88	-	14.50	8.00	0.25	12.00	6.25	963	13.25	12.25	63.50	-	-	-	-	-
CR(N) 45-6 H 50	3	3	41.38	66.75	4.88	46.88	58.88	16.88	-	14.50	8.00	0.25	12.00	6.25	963	13.25	12.25	63.50	-	-	-	-	-
CR(N) 45-7-2 H 50	3	3	44.50	69.88	4.88	50.00	62.00	16.88	-	14.50	8.00	0.25	12.00	6.25	980	13.25	12.25	66.63	-	-	-	-	-
CR(N) 45-7 H 60	3	3	44.50	71.88	4.88	50.63	62.88	16.88	-	14.63	9.00	-0.75	12.25	7.00	1254	15.13	13.25	68.50	-	-	-	-	-
CR(N) 45-8-1 H 60	3	3	47.63	75.00	4.88	53.75	66.00	16.88	-	14.63	9.00	-0.75	12.25	7.00	1265	15.13	13.25	71.75	-	-	-	-	-

Note: Terminal box is on top of ML motors (through 30 HP). Baldor motors have terminal box on the side (40 HP and larger). Reference D2 dimension. Weights are based on pump with TEFC motor.

\* Dimensions shown for three-phase MLE motors are for 460 V versions. See page 19 for 200-240 V, three-phase dimensions.

★ Add 0.67 inches for CRN-H dimensions.

**CR, CRE, CRN, CRNE 45 H GC/G10/G30/G60**

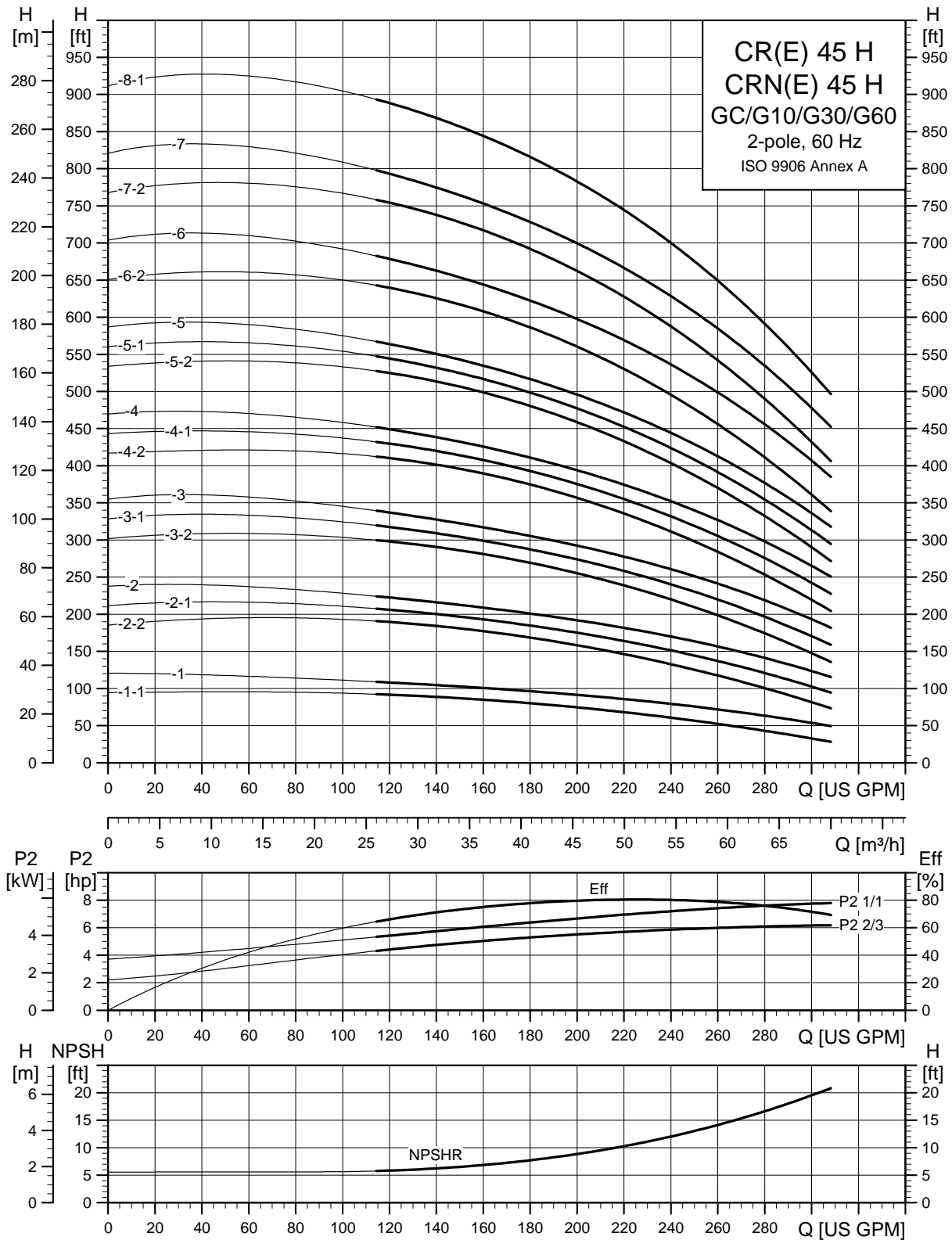

CR, CRE, CRN, CRNE 45 H GC/G10/G30/G60

TM04 6297 0912

Dimensions and weights GC (3" x 2" x 6")

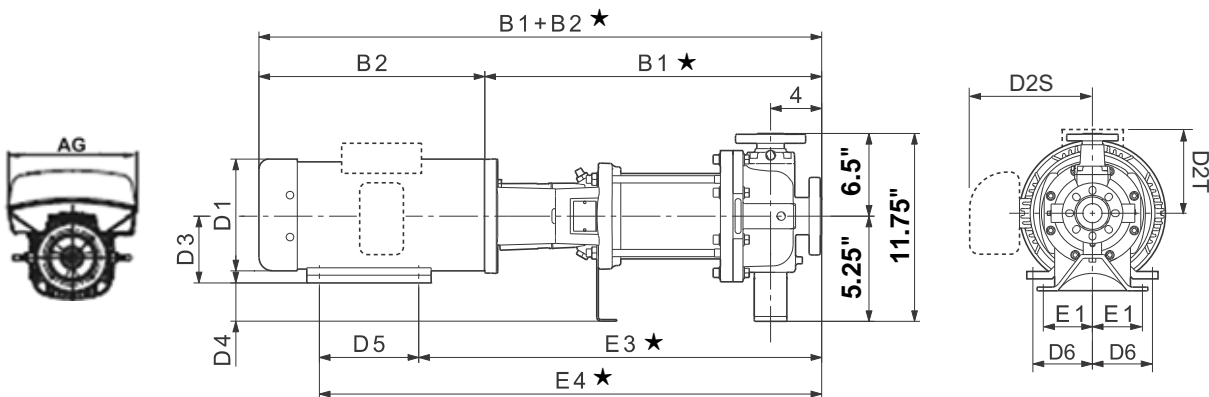

TM06 9699 1014 - TM06 1063 1514

Pump type	HP	PH	Dimensions [in] TEFC											Ship. wt. [lbs]	Dimensions [in] ODP			Dimensions [in] MLE*				Ship. wt. [lbs]					
			B1 ★	B1+ B2 ★	E1	E3 ★	E4 ★	D1	D2T	D2S	D3	D4	D5		D6	D1	D2	B1+ B2 ★	D1	D2	AG		B1+ B2 ★				
CR(N)(E) 45-1-1 H 7 1/2	1	3	27.38	42.88	3.00	31.88	37.38	10.25	7.63	-	5.25	0	5.50	4.25	301	-	-	-	-	-	-	-	-				
			27.38	42.88	3.00	31.88	37.38	8.63	5.25	-	5.25	0	5.50	4.25	280	-	-	-	7.53	7.91	11.46	41.75	271				
CR(N)(E) 45-1 H	10	3	27.38	43.38	3.00	31.88	38.88	10.25	10.25	-	5.25	0	7.00	4.25	356	-	-	-	-	-	-	-	-				
			27.38	42.50	3.00	31.88	38.88	10.25	6.25	-	5.25	0	7.00	4.25	304	-	-	-	10.04	9.33	13.62	42.69	273				
CR(N)(E) 45-2-2 H	15	3	30.00	48.50	3.00	35.00	43.25	12.38	8.00	-	6.25	-1.00	8.25	5.00	389	10.63	8.00	48.13	10.63	8.00	48.13	10.04	9.33	13.62	45.98	343	
CR(N) 45-2-1 H	15	3	30.00	48.50	3.00	35.00	43.25	12.38	8.00	-	6.25	-1.00	8.25	5.00	389	10.63	8.00	48.13	10.63	8.00	48.13	10.04	9.33	13.62	45.98	343	
CR(N)(E) 45-2 H	15	3	30.00	48.50	3.00	35.00	43.25	12.38	8.00	-	6.25	-1.00	8.25	5.00	389	10.63	8.00	48.13	10.63	8.00	48.13	10.04	9.33	13.62	45.98	343	
CR(N)(E) 45-3-2 H	20	3	33.13	51.63	3.00	38.13	48.13	12.38	8.00	-	6.25	-1.00	10.00	5.00	410	11.50	9.00	51.13	13.39	12.13	16.54	51.91	13.39	12.13	16.54	51.91	520
CR(N) 45-3-1 H	25	3	33.13	55.50	3.00	38.13	47.63	12.38	8.00	-	7.00	-1.75	9.50	5.50	438	11.50	11.38	52.25	13.39	12.13	16.54	55.85	13.39	12.13	16.54	55.85	551
CR(N)(E) 45-3 H	25	3	33.13	55.50	3.00	38.13	47.63	12.38	8.00	-	7.00	-1.75	9.50	5.50	440	11.50	11.38	52.25	13.39	12.13	16.54	55.85	13.39	12.13	16.54	55.85	553
CR(N)(E) 45-4-2 H	30	3	36.25	58.63	3.00	41.25	52.25	12.38	8.00	-	7.00	-1.75	11.00	5.50	542	11.50	11.38	56.88	13.39	12.13	16.54	58.97	13.39	12.13	16.54	58.97	657
CR(N) 45-4-1 H	30	3	36.25	58.63	3.00	41.25	52.25	12.38	8.00	-	7.00	-1.75	11.00	5.50	542	11.50	11.38	56.88	13.39	12.13	16.54	58.97	13.39	12.13	16.54	58.97	657
CR(N)(E) 45-4 H	30	3	36.25	58.63	3.00	41.25	52.25	12.38	8.00	-	7.00	-1.75	11.00	5.50	542	11.50	11.38	56.88	13.39	12.13	16.54	58.97	13.39	12.13	16.54	58.97	657
CR(N) 45-5-2 H	40	3	39.50	62.63	3.00	44.50	55.50	15.00	-	13.13	7.00	-1.75	11.00	5.50	802	13.25	12.25	60.63	-	-	-	-	-	-	-	-	-
CR(N) 45-5-1 H	40	3	39.50	62.63	3.00	44.50	55.50	15.00	-	13.13	7.00	-1.75	11.00	5.50	802	13.25	12.25	60.63	-	-	-	-	-	-	-	-	-
CR(N) 45-5 H	40	3	39.50	62.63	3.00	44.50	55.50	15.00	-	13.13	7.00	-1.75	11.00	5.50	802	13.25	12.25	60.63	-	-	-	-	-	-	-	-	-
CR(N) 45-6-2 H	50	3	42.63	68.00	3.00	48.13	60.13	16.88	-	14.50	8.00	-2.75	12.00	6.25	870	13.25	12.25	64.75	-	-	-	-	-	-	-	-	-
CR(N) 45-6 H	50	3	42.63	68.00	3.00	48.13	60.13	16.88	-	14.50	8.00	-2.75	12.00	6.25	870	13.25	12.25	64.75	-	-	-	-	-	-	-	-	-
CR(N) 45-7-2 H	50	3	45.75	71.13	3.00	51.25	63.25	16.88	-	14.50	8.00	-2.75	12.00	6.25	888	13.25	12.25	67.88	-	-	-	-	-	-	-	-	-
CR(N) 45-7 H	60	3	45.75	73.13	3.00	51.88	64.13	16.88	-	14.63	9.00	-3.75	12.25	7.00	1164	15.13	13.25	69.75	-	-	-	-	-	-	-	-	-
CR(N) 45-8-1 H	60	3	48.88	76.25	3.00	55.00	67.25	16.88	-	14.63	9.00	-3.75	12.25	7.00	1173	15.13	13.25	73.00	-	-	-	-	-	-	-	-	-

Note: Terminal box is on top of ML motors (through 30 HP). Baldor motors have terminal box on the side (40 HP and larger). Reference D2 dimension. Weights are based on pump with TEFC motor.

\* Dimensions shown for three-phase MLE motors are for 460 V versions. See page 19 for 200-240 V, three-phase dimensions.

★ Add 0.16 inches for CRN-H dimensions.

Dimensions and weights G10 (3" x 2" x 6")

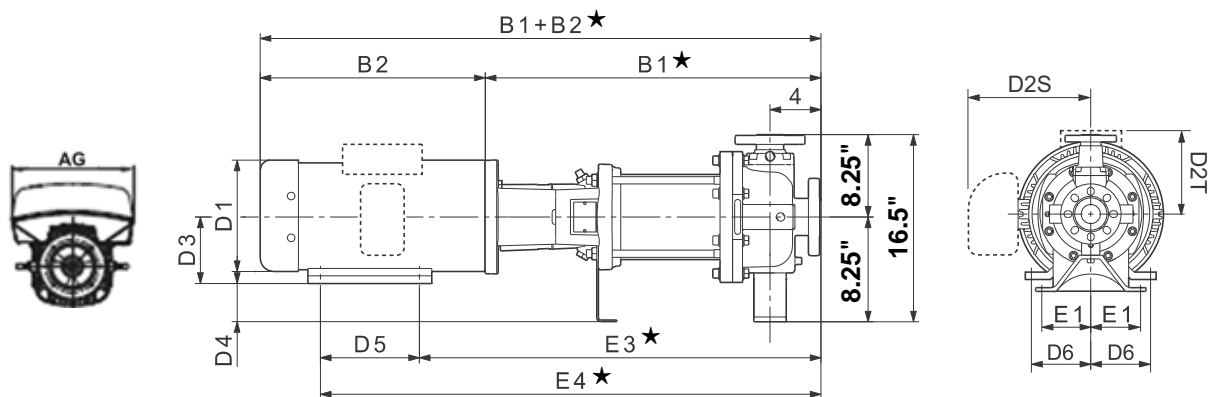

TM06 2478 1014 - TM06 1063 1514

Pump type	HP	PH	Dimensions [in] TEFC											Ship. wt. [lbs]	Dimensions [in] ODP			Dimensions [in] MLE*				Ship. wt. [lbs]	
			B1★	B1+B2★	E1	E3★	E4★	D1	D2T	D2S	D3	D4	D5		D6	D1	D2	B1+B2★	D1	D2	AG		B1+B2★
CR(N)(E) 45-1-1 H 7 1/2	1	3	26.13	41.63	4.88	30.63	36.13	10.25	7.63	-	5.25	3.00	5.50	4.25	389	-	-	-	-	-	-	-	-
			26.13	41.63	4.88	30.63	36.13	8.63	5.25	-	5.25	3.00	5.50	4.25	368	-	-	-	7.53	7.91	11.46	40.50	359
CR(N)(E) 45-1 H 10	1	3	26.13	42.13	4.88	30.63	37.63	10.25	10.25	-	5.25	3.00	7.00	4.25	444	-	-	-	-	-	-	-	-
			26.13	41.25	4.88	30.63	37.63	10.25	6.25	-	5.25	3.00	7.00	4.25	392	-	-	-	10.04	9.33	13.62	41.44	361
CR(N)(E) 45-2-2 H 15	3	3	28.75	47.25	4.88	33.75	42.00	12.38	8.00	-	6.25	2.00	8.25	5.00	479	10.63	8.00	46.88	10.04	9.33	13.62	44.73	434
CR(N) 45-2-1 H 15	3	3	28.75	47.25	4.88	33.75	42.00	12.38	8.00	-	6.25	2.00	8.25	5.00	479	10.63	8.00	46.88	10.04	9.33	13.62	44.73	434
CR(N)(E) 45-2 H 15	3	3	28.75	47.25	4.88	33.75	42.00	12.38	8.00	-	6.25	2.00	8.25	5.00	479	10.63	8.00	46.88	10.04	9.33	13.62	44.73	434
CR(N)(E) 45-3-2 H 20	3	3	31.88	50.38	4.88	36.88	46.88	12.38	8.00	-	6.25	2.00	10.00	5.00	500	11.50	9.00	49.88	13.39	12.13	16.54	50.66	610
CR(N) 45-3-1 H 25	3	3	31.88	54.25	4.88	36.88	46.38	12.38	8.00	-	7.00	1.25	9.50	5.50	528	11.50	11.38	51.00	13.39	12.13	16.54	54.60	641
CR(N)(E) 45-3 H 25	3	3	31.88	54.25	4.88	36.88	46.38	12.38	8.00	-	7.00	1.25	9.50	5.50	528	11.50	11.38	51.00	13.39	12.13	16.54	54.60	641
CR(N)(E) 45-4-2 H 30	3	3	35.00	57.38	4.88	40.00	51.00	12.38	8.00	-	7.00	1.25	11.00	5.50	632	11.50	11.38	55.63	13.39	12.13	16.54	57.72	747
CR(N) 45-4-1 H 30	3	3	35.00	57.38	4.88	40.00	51.00	12.38	8.00	-	7.00	1.25	11.00	5.50	632	11.50	11.38	55.63	13.39	12.13	16.54	57.72	747
CR(N)(E) 45-4 H 30	3	3	35.00	57.38	4.88	40.00	51.00	12.38	8.00	-	7.00	1.25	11.00	5.50	632	11.50	11.38	55.63	13.39	12.13	16.54	57.72	747
CR(N) 45-5-2 H 40	3	3	38.13	61.38	4.88	43.13	54.13	15.00	-	13.13	7.00	1.25	11.00	5.50	894	13.25	12.25	59.38	-	-	-	-	-
CR(N) 45-5-1 H 40	3	3	38.13	61.38	4.88	43.13	54.13	15.00	-	13.13	7.00	1.25	11.00	5.50	894	13.25	12.25	59.38	-	-	-	-	-
CR(N) 45-5 H 40	3	3	38.13	61.38	4.88	43.13	54.13	15.00	-	13.13	7.00	1.25	11.00	5.50	894	13.25	12.25	59.38	-	-	-	-	-
CR(N) 45-6-2 H 50	3	3	41.38	66.75	4.88	46.88	58.88	16.88	-	14.50	8.00	0.25	12.00	6.25	965	13.25	12.25	63.50	-	-	-	-	-
CR(N) 45-6 H 50	3	3	41.38	66.75	4.88	46.88	58.88	16.88	-	14.50	8.00	0.25	12.00	6.25	965	13.25	12.25	63.50	-	-	-	-	-
CR(N) 45-7-2 H 50	3	3	44.50	69.88	4.88	50.00	62.00	16.88	-	14.50	8.00	0.25	12.00	6.25	982	13.25	12.25	66.63	-	-	-	-	-
CR(N) 45-7 H 60	3	3	44.50	71.88	4.88	50.63	62.88	16.88	-	14.63	9.00	-0.75	12.25	7.00	1256	15.13	13.25	68.50	-	-	-	-	-
CR(N) 45-8-1 H 60	3	3	47.63	75.00	4.88	53.75	66.00	16.88	-	14.63	9.00	-0.75	12.25	7.00	1265	15.13	13.25	71.75	-	-	-	-	-

Note: Terminal box is on top of ML motors (through 30 HP). Baldor motors have terminal box on the side (40 HP and larger). Reference D2 dimension. Weights are based on pump with TEFC motor.

\* Dimensions shown for three-phase MLE motors are for 460 V versions. See page 19 for 200-240 V, three-phase dimensions.

★ Add 0.67 inches for CRN-H dimensions.

Dimensions and weights sketches G30 (3" x 2" x 13")

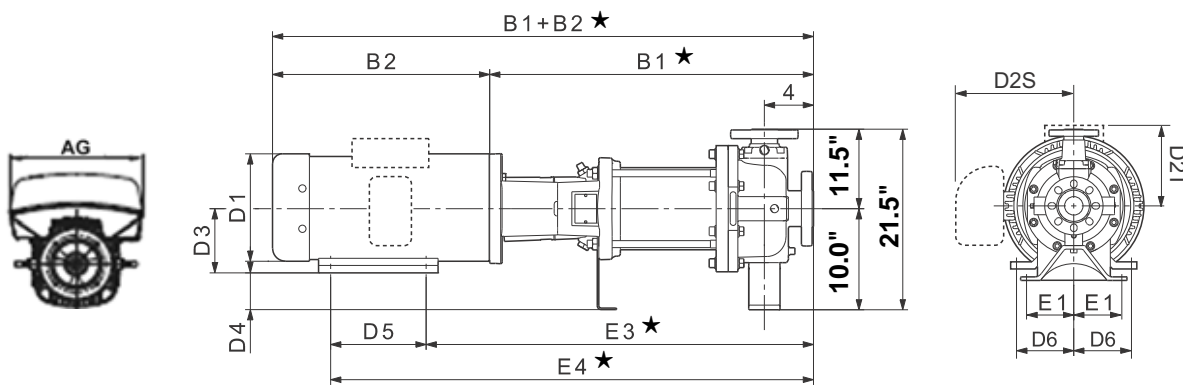

TM06 9699 1014 - TM06 1063 1514

Pump type	HP	PH	Dimensions [in] TEFC													Ship. wt. [lbs]	Dimensions [in] ODP			Dimensions [in] MLE*				Ship. wt. [lbs]
			B1 ★	B1+B2 ★	E1	E3 ★	E4 ★	D1	D2T	D2S	D3	D4	D5	D6	D1		D2	B1+B2 ★	D1	D2	AG	B1+B2 ★		
CR(N)(E) 45-1-1 H 7 1/2	1	3	26.13	41.63	4.88	30.63	36.13	10.25	7.63	-	5.25	4.75	5.50	4.25	470	-	-	-	-	-	-	-	-	
			26.13	41.63	4.88	30.63	36.13	8.63	5.25	-	5.25	4.75	5.50	4.25	450	-	-	-	7.53	7.91	11.46	40.50	440	
CR(N)(E) 45-1 H	10	3	26.13	42.13	4.88	30.63	37.63	10.25	10.25	-	5.25	4.75	7.00	4.25	525	-	-	-	-	-	-	-	-	
			26.13	41.25	4.88	30.63	37.63	10.25	6.25	-	5.25	4.75	7.00	4.25	473	-	-	-	10.04	9.33	13.62	41.44	442	
CR(N)(E) 45-2-2 H	15	3	28.75	47.25	4.88	33.75	42.00	12.38	8.00	-	6.25	3.75	8.25	5.00	560	10.63	8.00	46.88	10.04	9.33	13.62	44.73	515	
CR(N) 45-2-1 H	15	3	28.75	47.25	4.88	33.75	42.00	12.38	8.00	-	6.25	3.75	8.25	5.00	560	10.63	8.00	46.88	10.04	9.33	13.62	44.73	515	
CR(N)(E) 45-2 H	15	3	28.75	47.25	4.88	33.75	42.00	12.38	8.00	-	6.25	3.75	8.25	5.00	560	10.63	8.00	46.88	10.04	9.33	13.62	44.73	515	
CR(N)(E) 45-3-2 H	20	3	31.88	50.38	4.88	36.88	46.88	12.38	8.00	-	6.25	3.75	10.00	5.00	561	11.50	9.00	49.88	13.39	12.13	16.54	50.66	672	
CR(N) 45-3-1 H	25	3	31.88	54.25	4.88	36.88	46.38	12.38	8.00	-	7.00	3.00	9.50	5.50	590	11.50	11.38	51.00	13.39	12.13	16.54	54.60	703	
CR(N)(E) 45-3 H	25	3	31.88	54.25	4.88	36.88	46.38	12.38	8.00	-	7.00	3.00	9.50	5.50	590	11.50	11.38	51.00	13.39	12.13	16.54	54.60	703	
CR(N)(E) 45-4-2 H	30	3	35.00	57.38	4.88	40.00	51.00	12.38	8.00	-	7.00	3.00	11.00	5.50	623	11.50	11.38	55.63	13.39	12.13	16.54	57.72	738	
CR(N) 45-4-1 H	30	3	35.00	57.38	4.88	40.00	51.00	12.38	8.00	-	7.00	3.00	11.00	5.50	623	11.50	11.38	55.63	13.39	12.13	16.54	57.72	738	
CR(N)(E) 45-4 H	30	3	35.00	57.38	4.88	40.00	51.00	12.38	8.00	-	7.00	3.00	11.00	5.50	623	11.50	11.38	55.63	13.39	12.13	16.54	57.72	738	
CR(N) 45-5-2 H	40	3	38.13	61.38	4.88	43.13	54.13	15.00	-	13.13	7.00	3.00	11.00	5.50	887	13.25	12.25	59.38	-	-	-	-	-	
CR(N) 45-5-1 H	40	3	38.13	61.38	4.88	43.13	54.13	15.00	-	13.13	7.00	3.00	11.00	5.50	887	13.25	12.25	59.38	-	-	-	-	-	
CR(N) 45-5 H	40	3	38.13	61.38	4.88	43.13	54.13	15.00	-	13.13	7.00	3.00	11.00	5.50	887	13.25	12.25	59.38	-	-	-	-	-	
CR(N) 45-6-2 H	50	3	41.38	66.75	4.88	46.88	58.88	16.88	-	14.50	8.00	2.00	12.00	6.25	956	13.25	12.25	63.50	-	-	-	-	-	
CR(N) 45-6 H	50	3	41.38	66.75	4.88	46.88	58.88	16.88	-	14.50	8.00	2.00	12.00	6.25	956	13.25	12.25	63.50	-	-	-	-	-	
CR(N) 45-7-2 H	50	3	44.50	69.88	4.88	50.00	62.00	16.88	-	14.50	8.00	2.00	12.00	6.25	974	13.25	12.25	66.63	-	-	-	-	-	
CR(N) 45-7 H	60	3	44.50	71.88	4.88	50.63	62.88	16.88	-	14.63	9.00	1.00	12.25	7.00	1248	15.13	13.25	68.50	-	-	-	-	-	
CR(N) 45-8-1 H	60	3	47.63	75.00	4.88	53.75	66.00	16.88	-	14.63	9.00	1.00	12.25	7.00	1259	15.13	13.25	71.75	-	-	-	-	-	

Note: Terminal box is on top of ML motors (through 30 HP). Baldor motors have terminal box on the side (40 HP and larger). Reference D2 dimension. Weights are based on pump with TEFC motor.

\* Dimensions shown for three-phase MLE motors are for 460 V versions. See page 19 for 200-240 V, three-phase dimensions.

★ Add 0.67 inches for CRN-H dimensions.

Dimensions and weights G60 (3" x 2" x 8", 3" x 2" x 10")

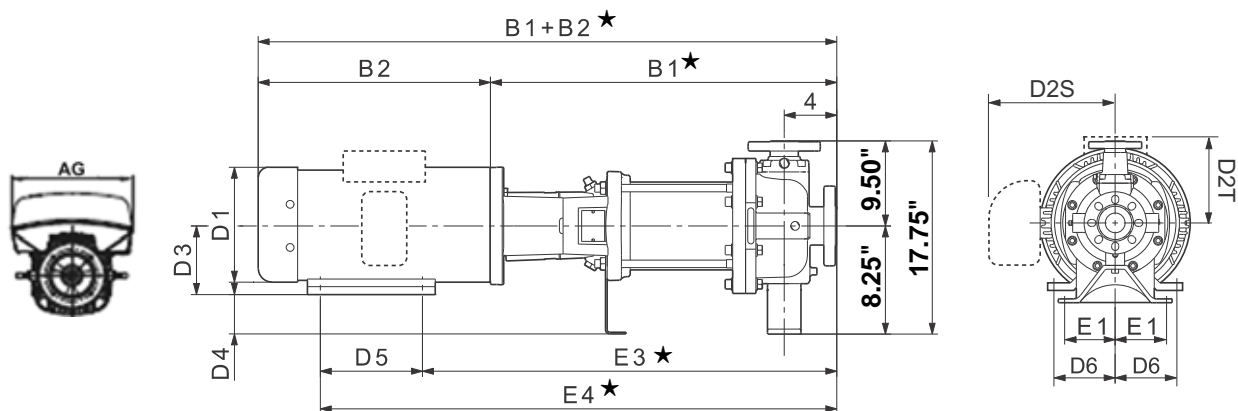

TM06 9699 1014 - TM06 1063 1514

Pump type	HP	PH	Dimensions [in] TEFC												Ship. wt. [lbs]	Dimensions [in] ODP			Dimensions [in] MLE*				Ship. wt. [lbs]				
			B1*	B1+B2*	E1	E3*	E4*	D1	D2T	D2S	D3	D4	D5	D6		D1	D2	B1+B2*	D1	D2	AG	B1+B2*					
CR(N)(E) 45-1-1 H	7 1/2	1	26.13	41.63	4.88	30.63	36.13	10.25	7.63	-	5.25	3.00	5.50	4.25	450	-	-	-	-	-	-	-	-	-	-	-	
		3	26.13	41.63	4.88	30.63	36.13	8.63	5.25	-	5.25	3.00	5.50	4.25	430	-	-	-	7.53	7.91	11.46	40.50	-	-	-	-	420
CR(N)(E) 45-1 H	10	1	26.13	42.13	4.88	30.63	37.63	10.25	10.25	-	5.25	3.00	7.00	4.25	505	-	-	-	-	-	-	-	-	-	-	-	-
		3	26.13	41.25	4.88	30.63	37.63	10.25	6.25	-	5.25	3.00	7.00	4.25	453	-	-	-	10.04	9.33	13.62	41.44	-	-	-	-	423
CR(N)(E) 45-2-2 H	15	3	28.75	47.25	4.88	33.75	42.00	12.38	8.00	-	6.25	2.00	8.25	5.00	540	10.63	8.00	46.88	10.04	9.33	13.62	44.73	-	-	-	-	495
CR(N) 45-2-1 H	15	3	28.75	47.25	4.88	33.75	42.00	12.38	8.00	-	6.25	2.00	8.25	5.00	540	10.63	8.00	46.88	10.04	9.33	13.62	44.73	-	-	-	-	495
CR(N)(E) 45-2 H	15	3	28.75	47.25	4.88	33.75	42.00	12.38	8.00	-	6.25	2.00	8.25	5.00	540	10.63	8.00	46.88	10.04	9.33	13.62	44.73	-	-	-	-	495
CR(N)(E) 45-3-2 H	20	3	31.88	50.38	4.88	36.88	46.88	12.38	8.00	-	6.25	2.00	10.00	5.00	542	11.50	9.00	49.88	13.39	12.13	16.54	50.66	-	-	-	-	652
CR(N) 45-3-1 H	25	3	31.88	54.25	4.88	36.88	46.38	12.38	8.00	-	7.00	1.25	9.50	5.50	570	11.50	11.38	51.00	13.39	12.13	16.54	54.60	-	-	-	-	683
CR(N)(E) 45-3 H	25	3	31.88	54.25	4.88	36.88	46.38	12.38	8.00	-	7.00	1.25	9.50	5.50	570	11.50	11.38	51.00	13.39	12.13	16.54	54.60	-	-	-	-	683
CR(N)(E) 45-4-2 H	30	3	35.00	57.38	4.88	40.00	51.00	12.38	8.00	-	7.00	1.25	11.00	5.50	632	11.50	11.38	55.63	13.39	12.13	16.54	57.72	-	-	-	-	747
CR(N) 45-4-1 H	30	3	35.00	57.38	4.88	40.00	51.00	12.38	8.00	-	7.00	1.25	11.00	5.50	632	11.50	11.38	55.63	13.39	12.13	16.54	57.72	-	-	-	-	747
CR(N)(E) 45-4 H	30	3	35.00	57.38	4.88	40.00	51.00	12.38	8.00	-	7.00	1.25	11.00	5.50	632	11.50	11.38	55.63	13.39	12.13	16.54	57.72	-	-	-	-	747
CR(N) 45-5-2 H	40	3	38.13	61.38	4.88	43.13	54.13	15.00	-	13.13	7.00	1.25	11.00	5.50	894	13.25	12.25	59.38	-	-	-	-	-	-	-	-	-
CR(N) 45-5-1 H	40	3	38.13	61.38	4.88	43.13	54.13	15.00	-	13.13	7.00	1.25	11.00	5.50	894	13.25	12.25	59.38	-	-	-	-	-	-	-	-	-
CR(N) 45-5 H	40	3	38.13	61.38	4.88	43.13	54.13	15.00	-	13.13	7.00	1.25	11.00	5.50	894	13.25	12.25	59.38	-	-	-	-	-	-	-	-	-
CR(N) 45-6-2 H	50	3	41.38	66.75	4.88	46.88	58.88	16.88	-	14.50	8.00	0.25	12.00	6.25	965	13.25	12.25	63.50	-	-	-	-	-	-	-	-	-
CR(N) 45-6 H	50	3	41.38	66.75	4.88	46.88	58.88	16.88	-	14.50	8.00	0.25	12.00	6.25	965	13.25	12.25	63.50	-	-	-	-	-	-	-	-	-
CR(N) 45-7-2 H	50	3	44.50	69.88	4.88	50.00	62.00	16.88	-	14.50	8.00	0.25	12.00	6.25	982	13.25	12.25	66.63	-	-	-	-	-	-	-	-	-
CR(N) 45-7 H	60	3	44.50	71.88	4.88	50.63	62.88	16.88	-	14.63	9.00	-0.75	12.25	7.00	1256	15.13	13.25	68.50	-	-	-	-	-	-	-	-	-
CR(N) 45-8-1 H	60	3	47.63	75.00	4.88	53.75	66.00	16.88	-	14.63	9.00	-0.75	12.25	7.00	1265	15.13	13.25	71.75	-	-	-	-	-	-	-	-	-

Note: Terminal box is on top of ML motors (through 30 HP). Baldor motors have terminal box on the side (40 HP and larger). Reference D2 dimension. Weights are based on pump with TEFC motor.

\* Dimensions shown for three-phase MLE motors are for 460 V versions. See page 19 for 200-240 V, three-phase dimensions.

★ Add 0.67 inches for CRN-H dimensions.

CR, CRE, CRN, CRNE 64 H G44

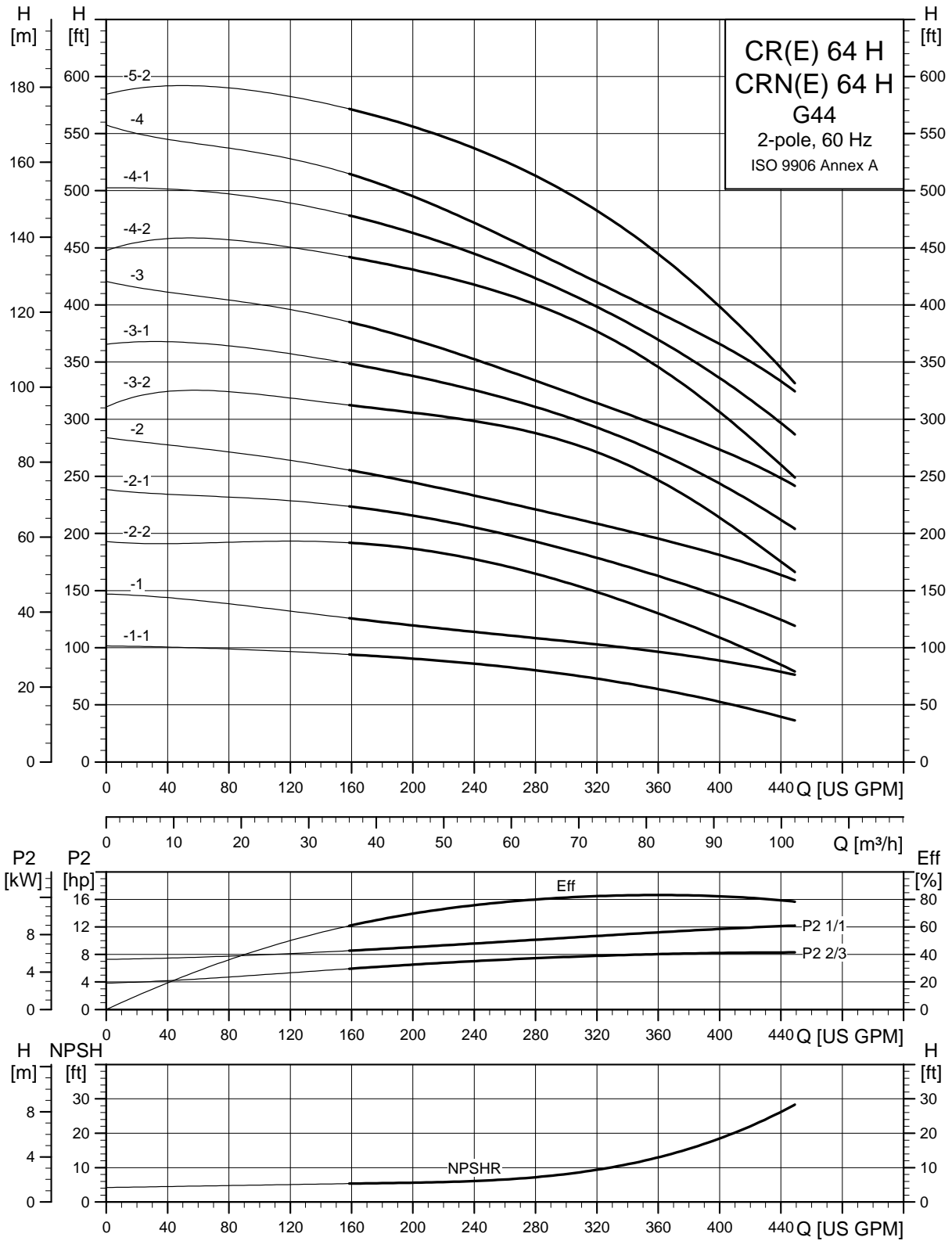

TM04 6302 0912



**CR, CRE, CRN, CRNE 64 H GC/G10/G30/G60**

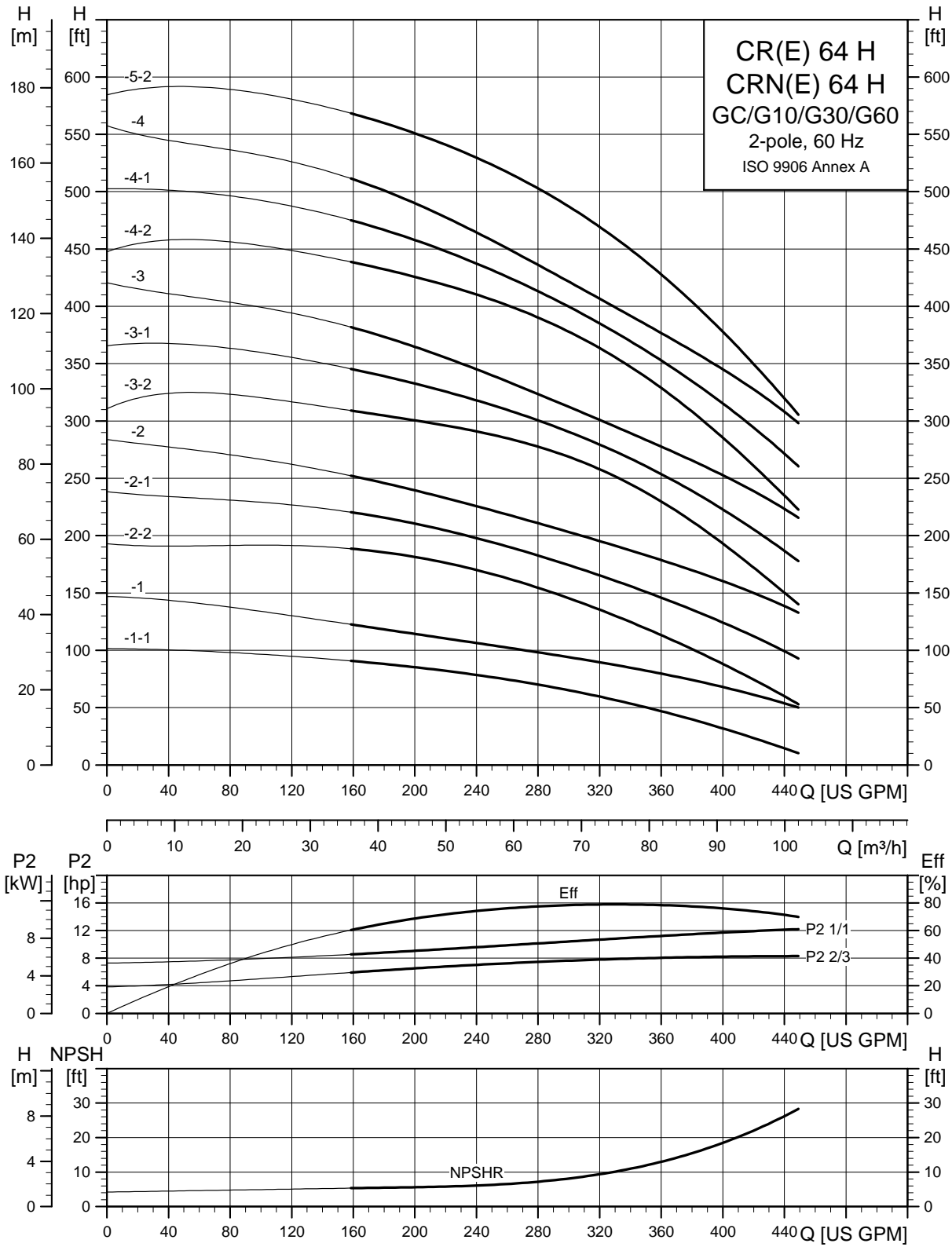

TM04 6300 0912

Dimensions and weights GC (3" x 2" x 6")

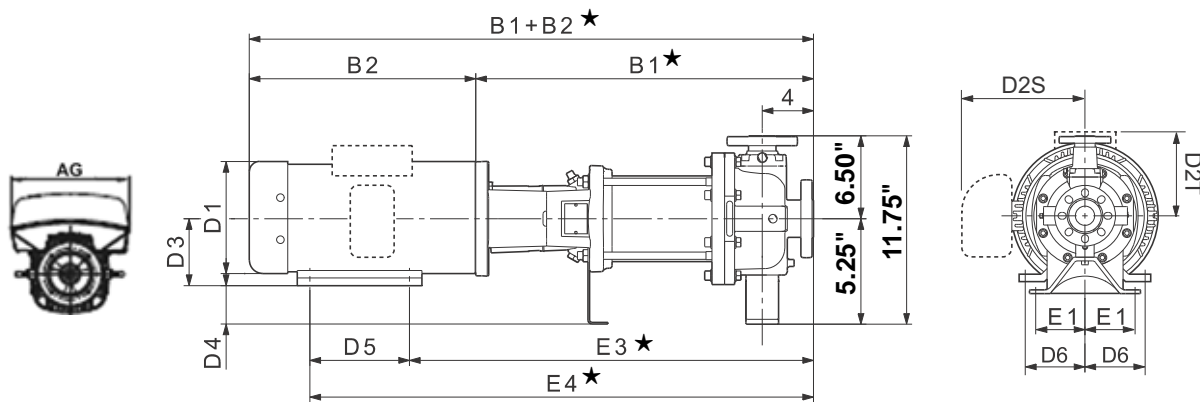

TM06 9699 1014 - TM06 1063 1514

Pump type	HP	PH	Dimensions [in] TEFC											Ship. wt. [lbs]	Dimensions [in] ODP			Dimensions [in] MLE*				Ship. wt. [lbs]		
			B1 ★	B1+ B2 ★	E1	E3 ★	E4 ★	D1	D2T	D2S	D3	D4	D5		D6	D1	D2	B1+ B2 ★	D1	D2	AG		B1+ B2 ★	
CR(N)(E) 64-1-1 H	10	1	27.50	43.50	3.00	32.00	39.00	10.25	10.25	-	5.25	0.00	7.00	4.25	358	-	-	-	-	-	-	-	-	-
		3	27.50	42.63	3.00	32.00	39.00	10.25	6.25	-	5.25	0.00	7.00	4.25	327	-	-	-	10.04	9.33	13.62	42.81	-	275
CR(N)(E) 64-1 H	15	3	27.00	45.50	3.00	32.00	40.25	12.38	8.00	-	6.25	-1.00	8.25	5.00	435	10.63	8.00	45.13	10.04	9.33	13.62	42.98	-	339
CR(N) 64-2-2 H	20	3	30.25	48.75	3.00	35.25	45.25	12.38	8.00	-	6.25	-1.00	10.00	5.00	474	11.50	9.00	48.13	13.39	12.13	16.54	49.03	-	515
CR(N)(E) 64-2-1 H	20	3	30.25	48.75	3.00	35.25	45.25	12.38	8.00	-	6.25	-1.00	10.00	5.00	474	11.50	9.00	48.13	13.39	12.13	16.54	49.03	-	515
CR(N)(E) 64-2 H	25	3	30.25	52.63	3.00	35.25	44.75	12.38	8.00	-	7.00	-1.75	9.50	5.50	494	11.50	11.38	49.25	13.39	12.13	16.54	52.97	-	546
CR(N)(E) 64-3-2 H	30	3	33.50	55.88	3.00	38.50	49.50	12.38	8.00	-	7.00	-1.75	11.00	5.50	598	11.50	11.38	54.00	13.39	12.13	16.54	56.22	-	584
CR(N) 64-3-1 H	40	3	33.50	56.63	3.00	38.50	49.50	15.00	-	13.13	7.00	-1.75	11.00	5.50	720	13.25	12.25	54.63	-	-	-	-	-	-
CR(N) 64-3 H	40	3	33.50	56.63	3.00	38.50	49.50	15.00	-	13.13	7.00	-1.75	11.00	5.50	720	13.25	12.25	54.63	-	-	-	-	-	-
CR(N) 64-4-2 H	40	3	36.63	59.88	3.00	41.63	52.63	15.00	-	13.13	7.00	-1.75	11.00	5.50	815	13.25	12.25	57.88	-	-	-	-	-	-
CR(N) 64-4-1 H	50	3	36.63	62.13	3.00	42.13	54.13	16.88	-	14.50	8.00	-2.75	12.00	6.25	855	13.25	12.25	58.88	-	-	-	-	-	-
CR(N) 64-4 H	50	3	36.63	62.13	3.00	42.13	54.13	16.88	-	14.50	8.00	-2.75	12.00	6.25	855	13.25	12.25	58.88	-	-	-	-	-	-
CR(N) 64-5-2 H	60	3	39.88	67.38	3.00	46.00	58.25	16.88	-	14.63	9.00	-3.75	12.25	7.00	1138	15.13	13.25	64.00	-	-	-	-	-	-

Note: Terminal box is on top of ML motors (through 30 HP). Baldor motors have terminal box on the side (40 HP and larger). Reference D2 dimension. Weights are based on pump with TEFC motor.

\* Dimensions shown for three-phase MLE motors are for 460 V versions.

★ Add 0.16 inches for CRN-H dimensions.

Dimensions and weights G10 (3" x 2" x 6")

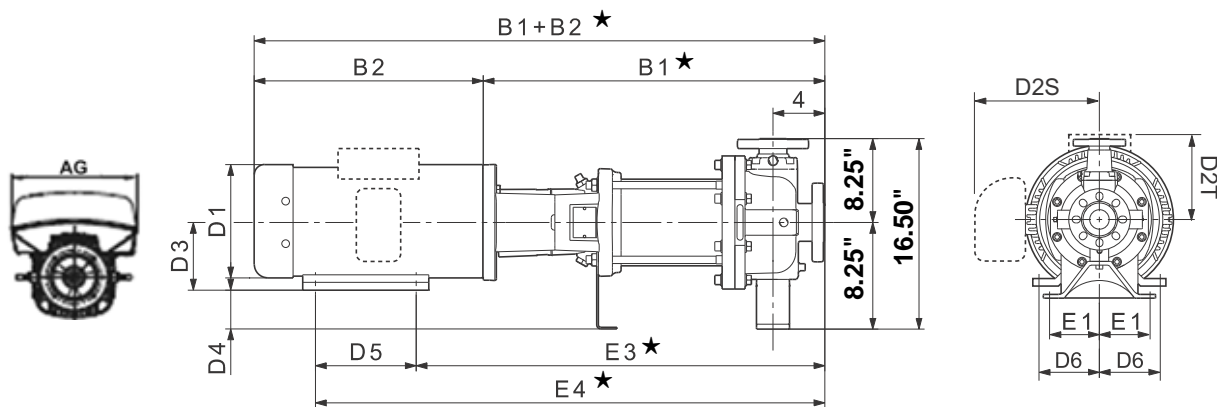

TM06 9699 1014 - TM06 1063 1514

Pump type	HP	PH	Dimensions [in] TEFC											Ship. wt. [lbs]	Dimensions [in] ODP			Dimensions [in] MLE*				Ship. wt. [lbs]		
			B1 ★	B1+ B2 ★	E1	E3 ★	E4 ★	D1	D2T	D2S	D3	D4	D5		D6	D1	D2	B1+ B2 ★	D1	D2	AG		B1+ B2 ★	
CR(N)(E) 64-1-1 H	10	1	26.25	42.25	4.88	30.75	37.75	10.25	10.25	-	5.25	3.00	7.00	4.25	448	-	-	-	-	-	-	-	-	-
		3	26.25	41.38	4.88	30.75	37.75	10.25	6.25	-	5.25	3.00	7.00	4.25	417	-	-	-	10.04	9.33	13.62	41.56	-	365
CR(N)(E) 64-1 H	15	3	25.63	44.25	4.88	30.63	38.88	12.38	8.00	-	6.25	2.00	8.25	5.00	525	10.63	8.00	43.88	10.04	9.33	13.62	41.61	-	429
CR(N) 64-2-2 H	20	3	28.88	47.50	4.88	33.88	43.88	12.38	8.00	-	6.25	2.00	10.00	5.00	565	11.50	9.00	46.88	13.39	12.13	16.54	47.66	-	606
CR(N)(E) 64-2-1 H	20	3	28.88	47.50	4.88	33.88	43.88	12.38	8.00	-	6.25	2.00	10.00	5.00	565	11.50	9.00	46.88	13.39	12.13	16.54	47.66	-	606
CR(N)(E) 64-2 H	25	3	28.88	51.25	4.88	33.88	43.38	12.38	8.00	-	7.00	1.25	9.50	5.50	585	11.50	11.38	48.00	13.39	12.13	16.54	51.60	-	637
CR(N)(E) 64-3-2 H	30	3	32.13	54.50	4.88	37.13	48.13	12.38	8.00	-	7.00	1.25	11.00	5.50	688	11.50	11.38	52.75	13.39	12.13	16.54	54.85	-	674
CR(N) 64-3-1 H	40	3	32.13	55.38	4.88	37.13	48.13	15.00	-	13.13	7.00	1.25	11.00	5.50	810	13.25	12.25	53.38	-	-	-	-	-	-
CR(N) 64-3 H	40	3	32.13	55.38	4.88	37.13	48.13	15.00	-	13.13	7.00	1.25	11.00	5.50	810	13.25	12.25	53.38	-	-	-	-	-	-
CR(N) 64-4-2 H	40	3	35.38	58.63	4.88	40.38	51.38	15.00	-	13.13	7.00	1.25	11.00	5.50	907	13.25	12.25	56.63	-	-	-	-	-	-
CR(N) 64-4-1 H	50	3	35.38	60.88	4.88	40.88	52.88	16.88	-	14.50	8.00	0.25	12.00	6.25	947	13.25	12.25	57.63	-	-	-	-	-	-
CR(N) 64-4 H	50	3	35.38	60.88	4.88	40.88	52.88	16.88	-	14.50	8.00	0.25	12.00	6.25	947	13.25	12.25	57.63	-	-	-	-	-	-
CR(N) 64-5-2 H	60	3	38.63	66.13	4.88	44.75	57.00	16.88	-	14.63	9.00	-0.75	12.25	7.00	1232	15.13	13.25	62.75	-	-	-	-	-	-

Note: Terminal box is on top of ML motors (through 30 HP). Baldor motors have terminal box on the side (40 HP and larger). Reference D2 dimension. Weights are based on pump with TEFC motor.

\* Dimensions shown for three-phase MLE motors are for 460 V versions.

★ Add 0.67 inches for CRN-H dimensions.

Dimensions and weights G30 (3" x 2" x 13")

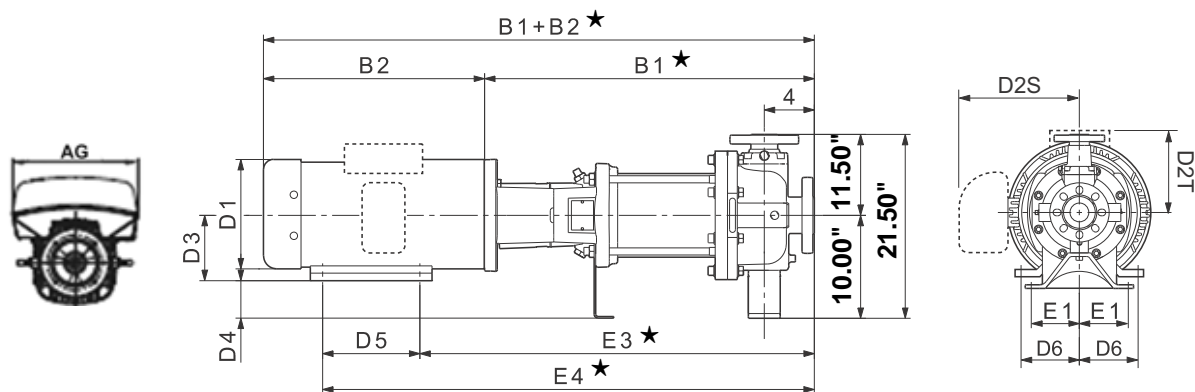

TM06 9699 1014 - TM06 1063 1514

Pump type	HP	PH	Dimensions [in] TEFC											Ship. wt. [lbs]	Dimensions [in] ODP			Dimensions [in] MLE*				Ship. wt. [lbs]		
			B1 ★	B1+ B2 ★	E1	E3 ★	E4 ★	D1	D2T	D2S	D3	D4	D5		D6	D1	D2	B1+ B2 ★	D1	D2	AG		B1+ B2 ★	
CR(N)(E) 64-1-1 H	10	1	26.25	42.25	4.88	30.75	37.75	10.25	10.25	-	5.25	4.75	7.00	4.25	527	-	-	-	-	-	-	-	-	-
		3	26.25	41.38	4.88	30.75	37.75	10.25	6.25	-	5.25	4.75	7.00	4.25	496	-	-	-	10.04	9.33	13.62	41.56	445	
CR(N)(E) 64-1 H	15	3	25.63	44.25	4.88	30.63	38.88	12.38	8.00	-	6.25	3.75	8.25	5.00	604	10.63	8.00	43.88	10.04	9.33	13.62	41.61	508	
CR(N) 64-2-2 H	20	3	28.88	47.50	4.88	33.88	43.88	12.38	8.00	-	6.25	3.75	10.00	5.00	626	11.50	9.00	46.88	13.39	12.13	16.54	47.66	667	
CR(N)(E) 64-2-1 H	20	3	28.88	47.50	4.88	33.88	43.88	12.38	8.00	-	6.25	3.75	10.00	5.00	626	11.50	9.00	46.88	13.39	12.13	16.54	47.66	667	
CR(N)(E) 64-2 H	25	3	28.88	51.25	4.88	33.88	43.38	12.38	8.00	-	7.00	3.00	9.50	5.50	646	11.50	11.38	48.00	13.39	12.13	16.54	51.60	698	
CR(N)(E) 64-3-2 H	30	3	32.13	54.50	4.88	37.13	48.13	12.38	8.00	-	7.00	3.00	11.00	5.50	750	11.50	11.38	52.75	13.39	12.13	16.54	54.85	736	
CR(N) 64-3-1 H	40	3	32.13	55.38	4.88	37.13	48.13	15.00	-	13.13	7.00	3.00	11.00	5.50	872	13.25	12.25	53.38	-	-	-	-	-	
CR(N) 64-3 H	40	3	32.13	55.38	4.88	37.13	48.13	15.00	-	13.13	7.00	3.00	11.00	5.50	872	13.25	12.25	53.38	-	-	-	-	-	
CR(N) 64-4-2 H	40	3	35.38	58.63	4.88	40.38	51.38	15.00	-	13.13	7.00	3.00	11.00	5.50	901	13.25	12.25	56.63	-	-	-	-	-	
CR(N) 64-4-1 H	50	3	35.38	60.88	4.88	40.88	52.88	16.88	-	14.50	8.00	2.00	12.00	6.25	941	13.25	12.25	57.63	-	-	-	-	-	
CR(N) 64-4 H	50	3	35.38	60.88	4.88	40.88	52.88	16.88	-	14.50	8.00	2.00	12.00	6.25	941	13.25	12.25	57.63	-	-	-	-	-	
CR(N) 64-5-2 H	60	3	38.63	66.13	4.88	44.75	57.00	16.88	-	14.63	9.00	1.00	12.25	7.00	1223	15.13	13.25	62.75	-	-	-	-	-	

Note: Terminal box is on top of ML motors (through 30 HP). Baldor motors have terminal box on the side (40 HP and larger). Reference D2 dimension. Weights are based on pump with TEFC motor.

\* Dimensions shown for three-phase MLE motors are for 460 V versions.

★ Add 0.67 inches for CRN-H dimensions.

Dimensions and weights G60 (3" x 2" x 8", 3" x 2" x 10")

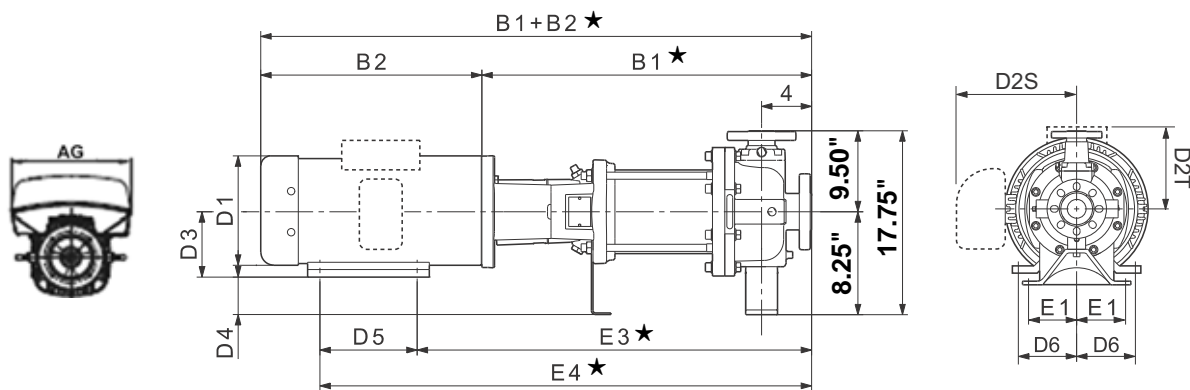

TM06 9699 1014 - TM06 1063 1514

Pump type	HP	PH	Dimensions [in]													Ship. wt. [lbs]	Dimensions [in]			Ship. wt. [lbs]			
			TEFC														ODP				MLE*		
			B1★	B1+B2★	E1	E3★	E4★	D1	D2T	D2S	D3	D4	D5	D6	D1	D2	B1+B2★	D1	D2	AG	B1+B2★		
CR(N)(E) 64-1-1 H	10	1	26.25	42.25	4.88	30.75	37.75	10.25	10.25	-	5.25	3.00	7.00	4.25	510	-	-	-	-	-	-	-	-
		3	26.25	41.38	4.88	30.75	37.75	10.25	6.25	-	5.25	3.00	7.00	4.25	479	-	-	-	10.04	9.33	13.62	41.56	427
CR(N)(E) 64-1 H	15	3	25.63	44.25	4.88	30.63	38.88	12.38	8.00	-	6.25	2.00	8.25	5.00	587	10.63	8.00	43.88	10.04	9.33	13.62	41.61	491
CR(N) 64-2-2 H	20	3	28.88	47.50	4.88	33.88	43.88	12.38	8.00	-	6.25	2.00	10.00	5.00	606	11.50	9.00	46.88	13.39	12.13	16.54	47.66	647
CR(N)(E) 64-2-1 H	20	3	28.88	47.50	4.88	33.88	43.88	12.38	8.00	-	6.25	2.00	10.00	5.00	606	11.50	9.00	46.88	13.39	12.13	16.54	47.66	647
CR(N)(E) 64-2 H	25	3	28.88	51.25	4.88	33.88	43.38	12.38	8.00	-	7.00	1.25	9.50	5.50	626	11.50	11.38	48.00	13.39	12.13	16.54	51.60	678
CR(N)(E) 64-3-2 H	30	3	32.13	54.50	4.88	37.13	48.13	12.38	8.00	-	7.00	1.25	11.00	5.50	732	11.50	11.38	52.75	13.39	12.13	16.54	54.85	718
CR(N) 64-3-1 H	40	3	32.13	55.38	4.88	37.13	48.13	15.00	-	13.13	7.00	1.25	11.00	5.50	854	13.25	12.25	53.38	-	-	-	-	-
CR(N) 64-3 H	40	3	32.13	55.38	4.88	37.13	48.13	15.00	-	13.13	7.00	1.25	11.00	5.50	854	13.25	12.25	53.38	-	-	-	-	-
CR(N) 64-4-2 H	40	3	35.38	58.63	4.88	40.38	51.38	15.00	-	13.13	7.00	1.25	11.00	5.50	909	13.25	12.25	56.63	-	-	-	-	-
CR(N) 64-4-1 H	50	3	35.38	60.88	4.88	40.88	52.88	16.88	-	14.50	8.00	0.25	12.00	6.25	949	13.25	12.25	57.63	-	-	-	-	-
CR(N) 64-4 H	50	3	35.38	60.88	4.88	40.88	52.88	16.88	-	14.50	8.00	0.25	12.00	6.25	949	13.25	12.25	57.63	-	-	-	-	-
CR(N) 64-5-2 H	60	3	38.63	66.13	4.88	44.75	57.00	16.88	-	14.63	9.00	-0.75	12.25	7.00	1232	15.13	13.25	62.75	-	-	-	-	-

Note: Terminal box is on top of ML motors (through 30 HP). Baldor motors have terminal box on the side (40 HP and larger). Reference D2 dimension. Weights are based on pump with TEFC motor.

\* Dimensions shown for three-phase MLE motors are for 460 V versions.

★ Add 0.67 inches for CRN-H dimensions.

**CR, CRE, CRN, CRNE 64 H G20/G50**

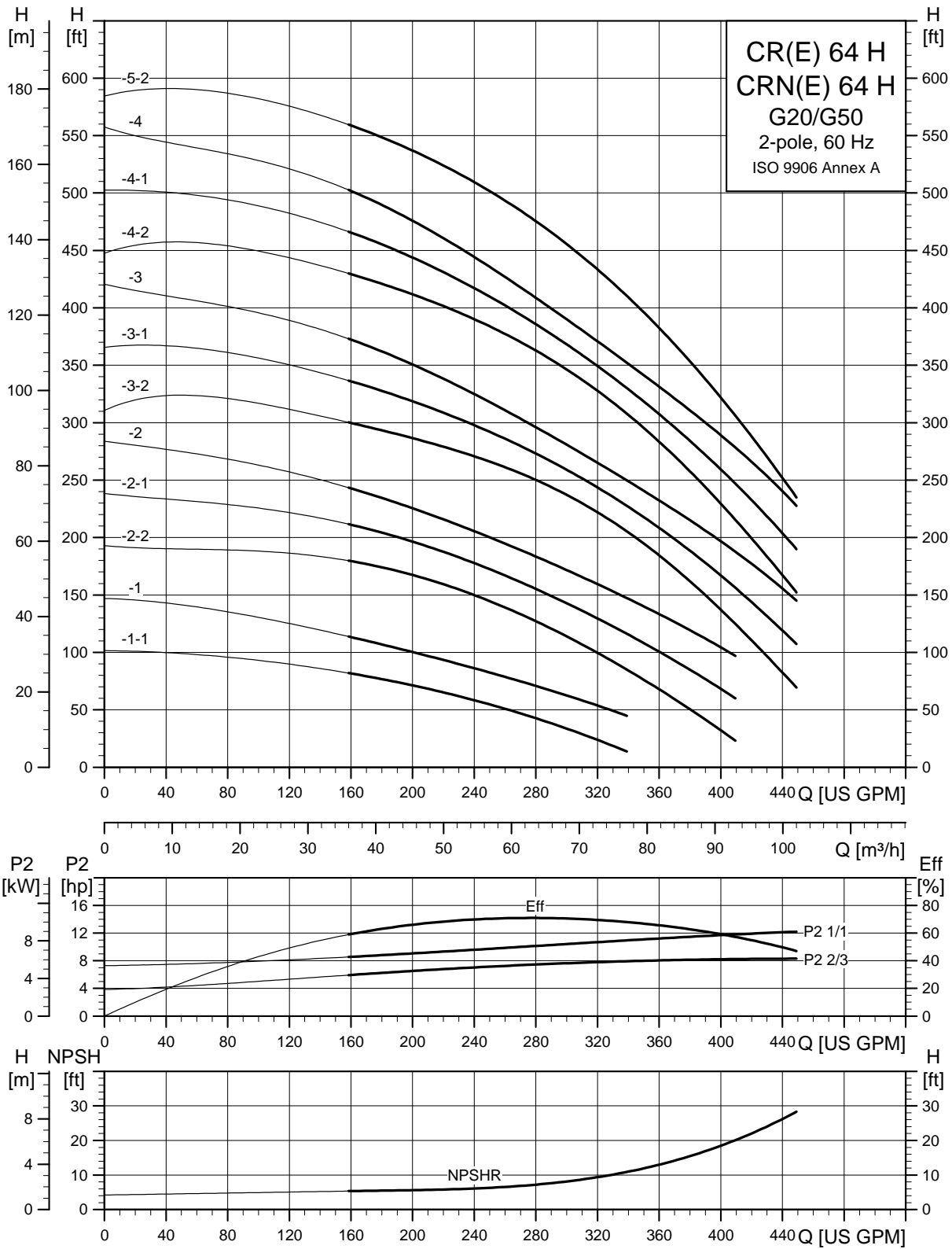

CR, CRE, CRN, CRNE 64 H G20/G50

TM04 6299 0912

Dimensions and weights G20 (3" x 1.5" x 13")

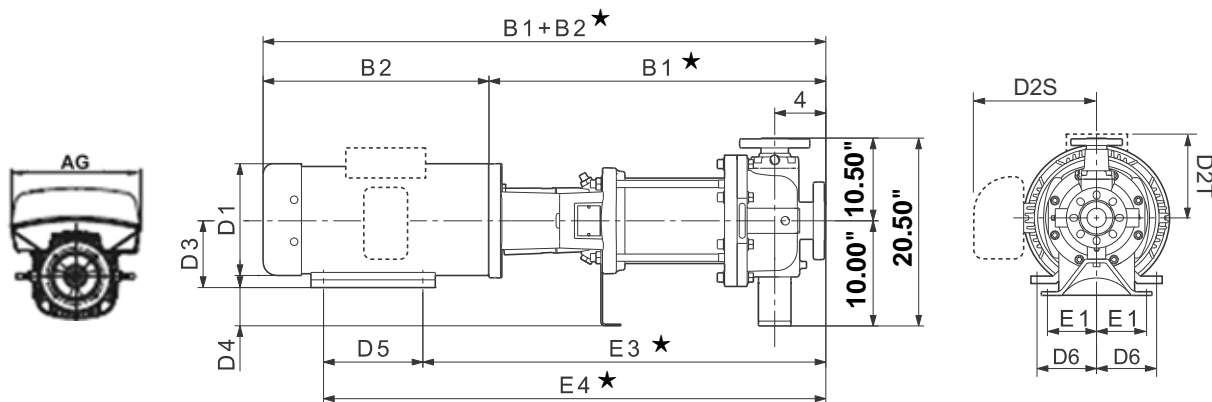

TM06 9699 1014 - TM06 1063 1514

Pump type	HP	PH	Dimensions [in] TEFC											Ship. wt. [lbs]	Dimensions [in] ODP			Dimensions [in] MLE*				Ship. wt. [lbs]	
			B1 ★	B1+ B2 ★	E1	E3 ★	E4 ★	D1	D2T	D2S	D3	D4	D5		D6	D1	D2	B1+ B2 ★	D1	D2	AG		B1+ B2 ★
CR(N)(E) 64-1-1 H	10	1	26.25	42.25	4.88	30.75	37.75	10.25	10.25	-	5.25	4.75	7.00	4.25	499	-	-	-	-	-	-	-	-
		3	26.25	41.38	4.88	30.75	37.75	10.25	6.25	-	5.25	4.75	7.00	4.25	468	-	-	-	10.04	9.33	13.62	41.56	416
CR(N)(E) 64-1 H	15	3	25.63	44.25	4.88	30.63	38.88	12.38	8.00	-	6.25	3.75	8.25	5.00	576	10.63	8.00	43.88	10.04	9.33	13.62	41.61	480
CR(N) 64-2-2 H	20	3	28.88	47.50	4.88	33.88	43.88	12.38	8.00	-	6.25	3.75	10.00	5.00	598	11.50	9.00	46.88	13.39	12.13	16.54	47.66	639
CR(N)(E) 64-2-1 H	20	3	28.88	47.50	4.88	33.88	43.88	12.38	8.00	-	6.25	3.75	10.00	5.00	598	11.50	9.00	46.88	13.39	12.13	16.54	47.66	639
CR(N)(E) 64-2 H	25	3	28.88	51.25	4.88	33.88	43.38	12.38	8.00	-	7.00	3.00	9.50	5.50	618	11.50	11.38	48.00	13.39	12.13	16.54	51.60	670
CR(N)(E) 64-3-2 H	30	3	32.13	54.50	4.88	37.13	48.13	12.38	8.00	-	7.00	3.00	11.00	5.50	724	11.50	11.38	52.75	13.39	12.13	16.54	54.85	710
CR(N) 64-3-1 H	40	3	32.13	55.38	4.88	37.13	48.13	15.00	-	13.13	7.00	3.00	11.00	5.50	846	13.25	12.25	53.38	-	-	-	-	-
CR(N) 64-3 H	40	3	32.13	55.38	4.88	37.13	48.13	15.00	-	13.13	7.00	3.00	11.00	5.50	846	13.25	12.25	53.38	-	-	-	-	-
CR(N) 64-4-2 H	40	3	35.38	58.63	4.88	40.38	51.38	15.00	-	13.13	7.00	3.00	11.00	5.50	901	13.25	12.25	56.63	-	-	-	-	-
CR(N) 64-4-1 H	50	3	35.38	60.88	4.88	40.88	52.88	16.88	-	14.50	8.00	2.00	12.00	6.25	941	13.25	12.25	57.63	-	-	-	-	-
CR(N) 64-4 H	50	3	35.38	60.88	4.88	40.88	52.88	16.88	-	14.50	8.00	2.00	12.00	6.25	941	13.25	12.25	57.63	-	-	-	-	-
CR(N) 64-5-2 H	60	3	38.63	66.13	4.88	44.75	57.00	16.88	-	14.63	9.00	1.00	12.25	7.00	1226	15.13	13.25	62.75	-	-	-	-	-

Note: Terminal box is on top of ML motors (through 30 HP). Baldor motors have terminal box on the side (40 HP and larger). Reference D2 dimension. Weights are based on pump with TEFC motor.

\* Dimensions shown for three-phase MLE motors are for 460 V versions.

★ Add 0.67 inches for CRN-H dimensions.

Dimensions and weights G50 (3" x 1.5" x 8", 3" x 1.5" x 10")

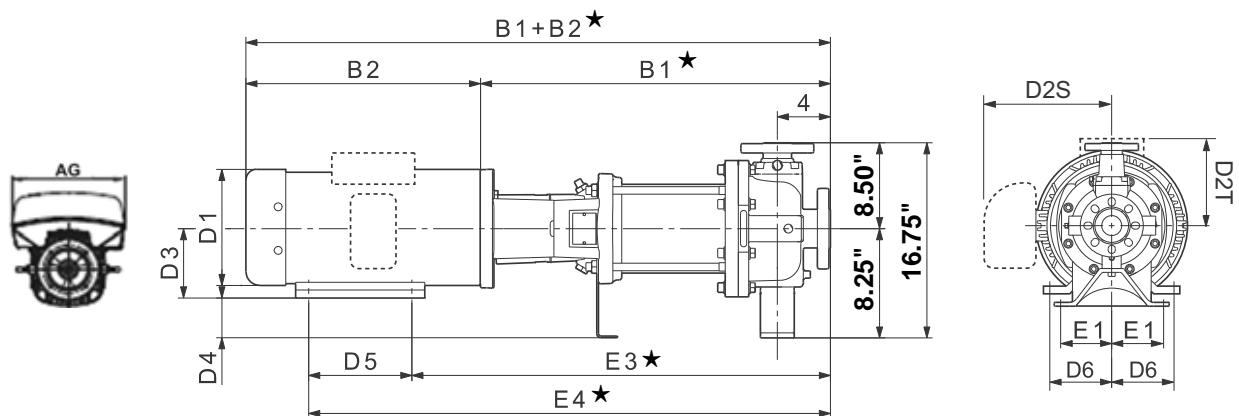

TM06 9699 1014 - TM06 1063 1514

Pump type	HP	PH	Dimensions [in] TEFC													Ship. wt. [lbs]	Dimensions [in] ODP			Dimensions [in] MLE*				Ship. wt. [lbs]
			B1★	B1+B2★	E1	E3★	E4★	D1	D2T	D2S	D3	D4	D5	D6	D1		D2	B1+B2★	D1	D2	AG	B1+B2★		
CR(N)(E) 64-1-1 H	10	1	26.25	42.25	4.88	30.75	37.75	10.25	10.25	-	5.25	3.00	7.00	4.25	505	-	-	-	-	-	-	-		
		3	26.25	41.38	4.88	30.75	37.75	10.25	6.25	-	5.25	3.00	7.00	4.25	474	-	-	-	10.04	9.33	13.62	41.56	423	
CR(N)(E) 64-1 H	15	3	25.63	44.25	4.88	30.63	38.88	12.38	8.00	-	6.25	2.00	8.25	5.00	582	10.63	8.00	43.88	10.04	9.33	13.62	41.61	486	
CR(N) 64-2-2 H	20	3	28.88	47.50	4.88	33.88	43.88	12.38	8.00	-	6.25	2.00	10.00	5.00	606	11.50	9.00	46.88	13.39	12.13	16.54	47.66	647	
CR(N)(E) 64-2-1 H	20	3	28.88	47.50	4.88	33.88	43.88	12.38	8.00	-	6.25	2.00	10.00	5.00	606	11.50	9.00	46.88	13.39	12.13	16.54	47.66	647	
CR(N)(E) 64-2 H	25	3	28.88	51.25	4.88	33.88	43.38	12.38	8.00	-	7.00	1.25	9.50	5.50	626	11.50	11.38	48.00	13.39	12.13	16.54	51.60	678	
CR(N)(E) 64-3-2 H	30	3	32.13	54.50	4.88	37.13	48.13	12.38	8.00	-	7.00	1.25	11.00	5.50	728	11.50	11.38	52.75	13.39	12.13	16.54	54.85	714	
CR(N) 64-3-1 H	40	3	32.13	55.38	4.88	37.13	48.13	15.00	-	13.13	7.00	1.25	11.00	5.50	850	13.25	12.25	53.38	-	-	-	-	-	
CR(N) 64-3 H	40	3	32.13	55.38	4.88	37.13	48.13	15.00	-	13.13	7.00	1.25	11.00	5.50	850	13.25	12.25	53.38	-	-	-	-	-	
CR(N) 64-4-2 H	40	3	35.38	58.63	4.88	40.38	51.38	15.00	-	13.13	7.00	1.25	11.00	5.50	907	13.25	12.25	56.63	-	-	-	-	-	
CR(N) 64-4-1 H	50	3	35.38	60.88	4.88	40.88	52.88	16.88	-	14.50	8.00	0.25	12.00	6.25	947	13.25	12.25	57.63	-	-	-	-	-	
CR(N) 64-4 H	50	3	35.38	60.88	4.88	40.88	52.88	16.88	-	14.50	8.00	0.25	12.00	6.25	947	13.25	12.25	57.63	-	-	-	-	-	
CR(N) 64-5-2 H	60	3	38.63	66.13	4.88	44.75	57.00	16.88	-	14.63	9.00	-0.75	12.25	7.00	1230	15.13	13.25	62.75	-	-	-	-	-	

Note: Terminal box is on top of ML motors (through 30 HP). Baldor motors have terminal box on the side (40 HP and larger). Reference D2 dimension. Weights are based on pump with TEFC motor.

\* Dimensions shown for three-phase MLE motors are for 460 V versions.

★ Add 0.67 inches for CRN-H dimensions.

**CR, CRE, CRN, CRNE 64 H G40/G70**

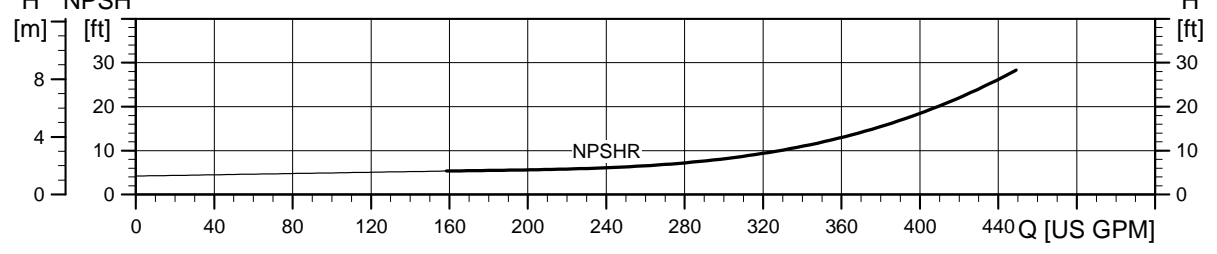
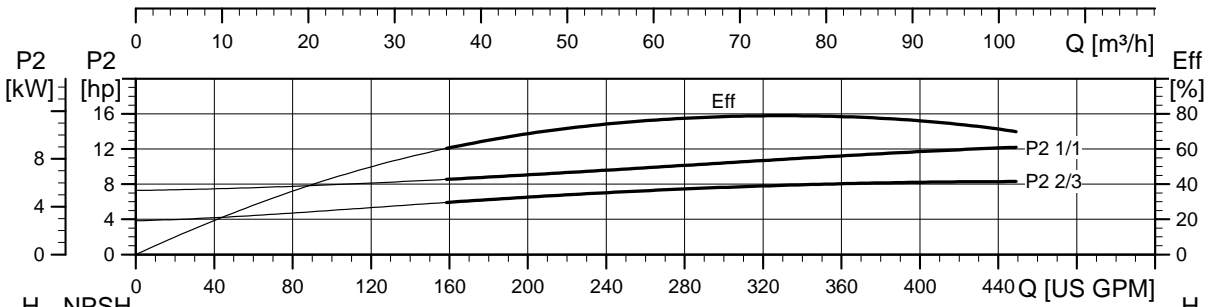
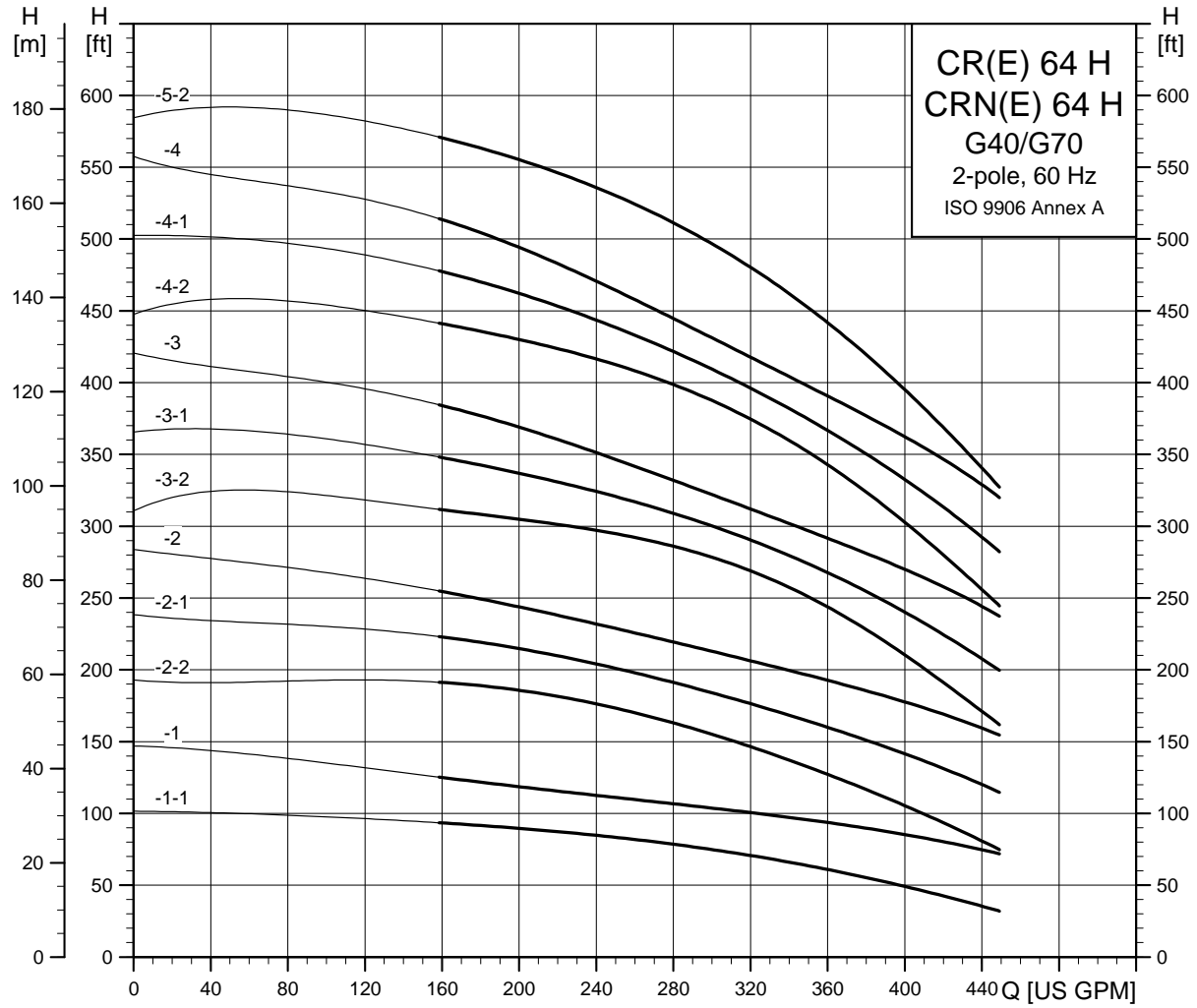

TM04 6301 0912

Dimensions and weights G40 (4" x 3" x 10", 4" x 3" x 13")

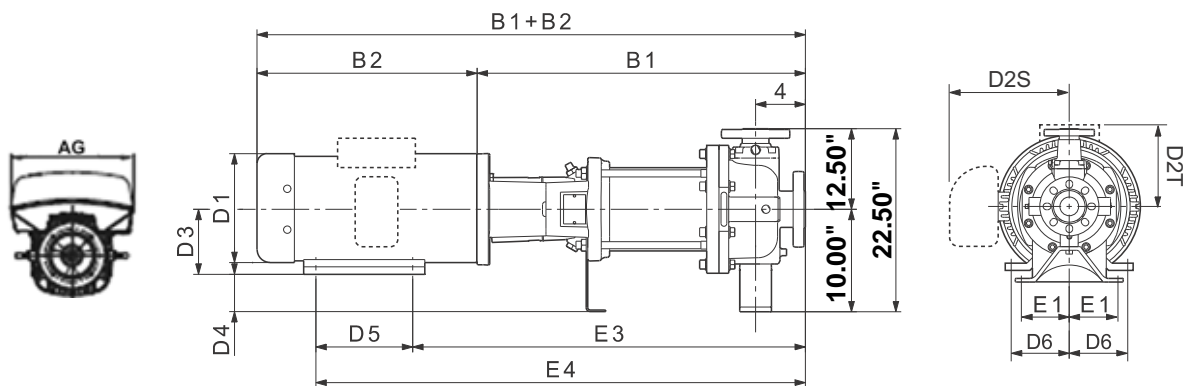

TM06 9699 1014 - TM06 1063 1514

Pump type	HP	PH	Dimensions [in]													Ship. wt. [lbs]	Dimensions [in]			Ship. wt. [lbs]			
			TEFC														ODP				MLE*		
			B1	B1+B2	E1	E3	E4	D1	D2T	D2S	D3	D4	D5	D6	D1	D2	B1+B2	D1	D2	AG	B1+B2		
CR(N)(E) 64-1-1 H	10	1	27.38	43.38	4.88	31.88	38.88	10.25	10.25	-	5.25	4.75	7.00	4.25	565	-	-	-	-	-	-	-	
		3	27.38	42.50	4.88	31.88	38.88	10.25	6.25	-	5.25	4.75	7.00	4.25	534	-	-	-	10.04	9.33	13.62	42.69	482
CR(N)(E) 64-1 H	15	3	26.88	45.38	4.88	31.88	40.13	12.38	8.00	-	6.25	3.75	8.25	5.00	642	10.63	8.00	45.00	10.04	9.33	13.62	42.86	546
CR(N) 64-2-2 H	20	3	30.13	48.63	4.88	35.13	45.13	12.38	8.00	-	6.25	3.75	10.00	5.00	661	11.50	9.00	48.00	13.39	12.13	16.54	48.91	702
CR(N)(E) 64-2-1 H	20	3	30.13	48.63	4.88	35.13	45.13	12.38	8.00	-	6.25	3.75	10.00	5.00	661	11.50	9.00	48.00	13.39	12.13	16.54	48.91	702
CR(N)(E) 64-2 H	25	3	30.13	52.50	4.88	35.13	44.63	12.38	8.00	-	7.00	3.00	9.50	5.50	681	11.50	11.38	49.13	13.39	12.13	16.54	52.85	733
CR(N)(E) 64-3-2 H	30	3	33.38	55.75	4.88	38.38	49.38	12.38	8.00	-	7.00	3.00	11.00	5.50	787	11.50	11.38	53.88	13.39	12.13	16.54	56.10	773
CR(N) 64-3-1 H	40	3	33.38	56.50	4.88	38.38	49.38	15.00	-	13.13	7.00	3.00	11.00	5.50	909	13.25	12.25	54.50	-	-	-	-	-
CR(N) 64-3 H	40	3	33.38	56.50	4.88	38.38	49.38	15.00	-	13.13	7.00	3.00	11.00	5.50	909	13.25	12.25	54.50	-	-	-	-	-
CR(N) 64-4-2 H	40	3	36.63	59.75	4.88	41.63	52.63	15.00	-	13.13	7.00	3.00	11.00	5.50	942	13.25	12.25	57.75	-	-	-	-	-
CR(N) 64-4-1 H	50	3	36.63	62.00	4.88	42.13	54.13	16.88	-	14.50	8.00	2.00	12.00	6.25	982	13.25	12.25	58.75	-	-	-	-	-
CR(N) 64-4 H	50	3	36.63	62.00	4.88	42.13	54.13	16.88	-	14.50	8.00	2.00	12.00	6.25	982	13.25	12.25	58.75	-	-	-	-	-
CR(N) 64-5-2 H	60	3	39.88	67.25	4.88	46.00	58.25	16.88	-	14.63	9.00	1.00	12.25	7.00	1276	15.13	13.25	63.88	-	-	-	-	-

Note: Terminal box is on top of ML motors (through 30 HP). Baldor motors have terminal box on the side (40 HP and larger). Reference D2 dimension. Weights are based on pump with TEFC motor.

\* Dimensions shown for three-phase MLE motors are for 460 V versions.

Dimensions and weights G70 (4" x 3" x 8", 4" x 3" x 10")

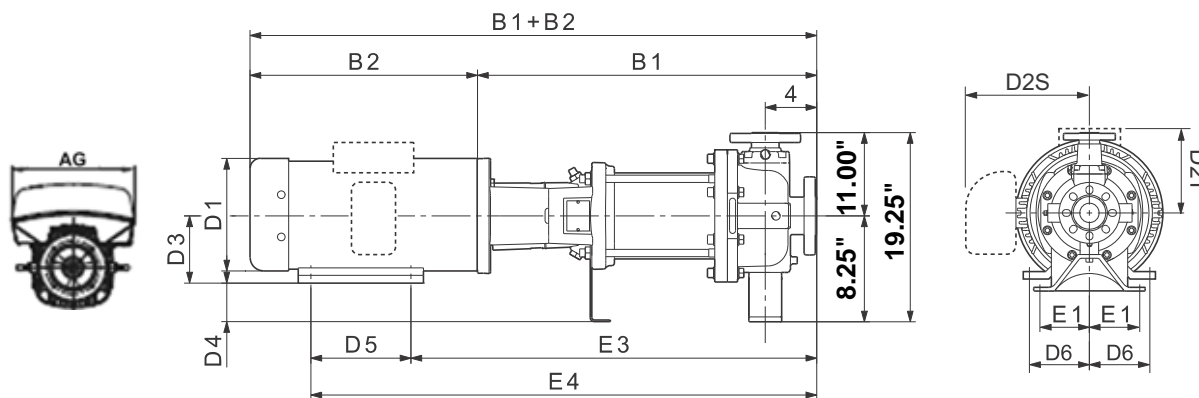

TM06 9699 1014 - TM06 1063 1514

Pump type	HP	PH	Dimensions [in] TEFC											Ship. wt. [lbs]	Dimensions [in] ODP			Dimensions [in] MLE*				Ship. wt. [lbs]	
			B1	B1+B2	E1	E3	E4	D1	D2T	D2S	D3	D4	D5		D6	D1	D2	B1+B2	D1	D2	AG		B1+B2
CR(N)(E) 64-1-1 H	10	1	27.38	43.38	4.88	31.88	38.88	10.25	10.25	-	5.25	3.00	7.00	4.25	536	-	-	-	-	-	-	-	-
		3	27.38	42.50	4.88	31.88	38.88	10.25	6.25	-	5.25	3.00	7.00	4.25	505	-	-	-	10.04	9.33	13.62	42.86	453
CR(N)(E) 64-1 H	15	3	26.88	45.38	4.88	31.88	40.13	12.38	8.00	-	6.25	2.00	8.25	5.00	613	10.63	8.00	45.00	10.04	9.33	13.62	42.86	517
CR(N) 64-2-2 H	20	3	30.13	48.63	4.88	35.13	45.13	12.38	8.00	-	6.25	2.00	10.00	5.00	635	11.50	9.00	48.00	13.39	12.13	16.54	48.91	676
CR(N)(E) 64-2-1 H	20	3	30.13	48.63	4.88	35.13	45.13	12.38	8.00	-	6.25	2.00	10.00	5.00	635	11.50	9.00	48.00	13.39	12.13	16.54	48.91	676
CR(N)(E) 64-2 H	25	3	30.13	52.50	4.88	35.13	44.63	12.38	8.00	-	7.00	1.25	9.50	5.50	655	11.50	11.38	49.13	13.39	12.13	16.54	52.85	707
CR(N)(E) 64-3-2 H	30	3	33.38	55.75	4.88	38.38	49.38	12.38	8.00	-	7.00	1.25	11.00	5.50	759	11.50	11.38	53.88	13.39	12.13	16.54	56.10	745
CR(N) 64-3-1 H	40	3	33.38	56.50	4.88	38.38	49.38	15.00	-	13.13	7.00	1.25	11.00	5.50	881	13.25	12.25	54.50	-	-	-	-	-
CR(N) 64-3 H	40	3	33.38	56.50	4.88	38.38	49.38	15.00	-	13.13	7.00	1.25	11.00	5.50	881	13.25	12.25	54.50	-	-	-	-	-
CR(N) 64-4-2 H	40	3	36.63	59.75	4.88	41.63	52.63	15.00	-	13.13	7.00	1.25	11.00	5.50	940	13.25	12.25	57.75	-	-	-	-	-
CR(N) 64-4-1 H	50	3	36.63	62.00	4.88	42.13	54.13	16.88	-	14.50	8.00	0.25	12.00	6.25	980	13.25	12.25	58.75	-	-	-	-	-
CR(N) 64-4 H	50	3	36.63	62.00	4.88	42.13	54.13	16.88	-	14.50	8.00	0.25	12.00	6.25	980	13.25	12.25	58.75	-	-	-	-	-
CR(N) 64-5-2 H	60	3	39.88	67.25	4.88	46.00	58.25	16.88	-	14.63	9.00	-0.75	12.25	7.00	1274	15.13	13.25	63.88	-	-	-	-	-

Note: Terminal box is on top of ML motors (through 30 HP). Baldor motors have terminal box on the side (40 HP and larger). Reference D2 dimension. Weights are based on pump with TEFC motor.

\* Dimensions shown for three-phase MLE motors are for 460 V versions.

**CR, CRN 90 H G44**

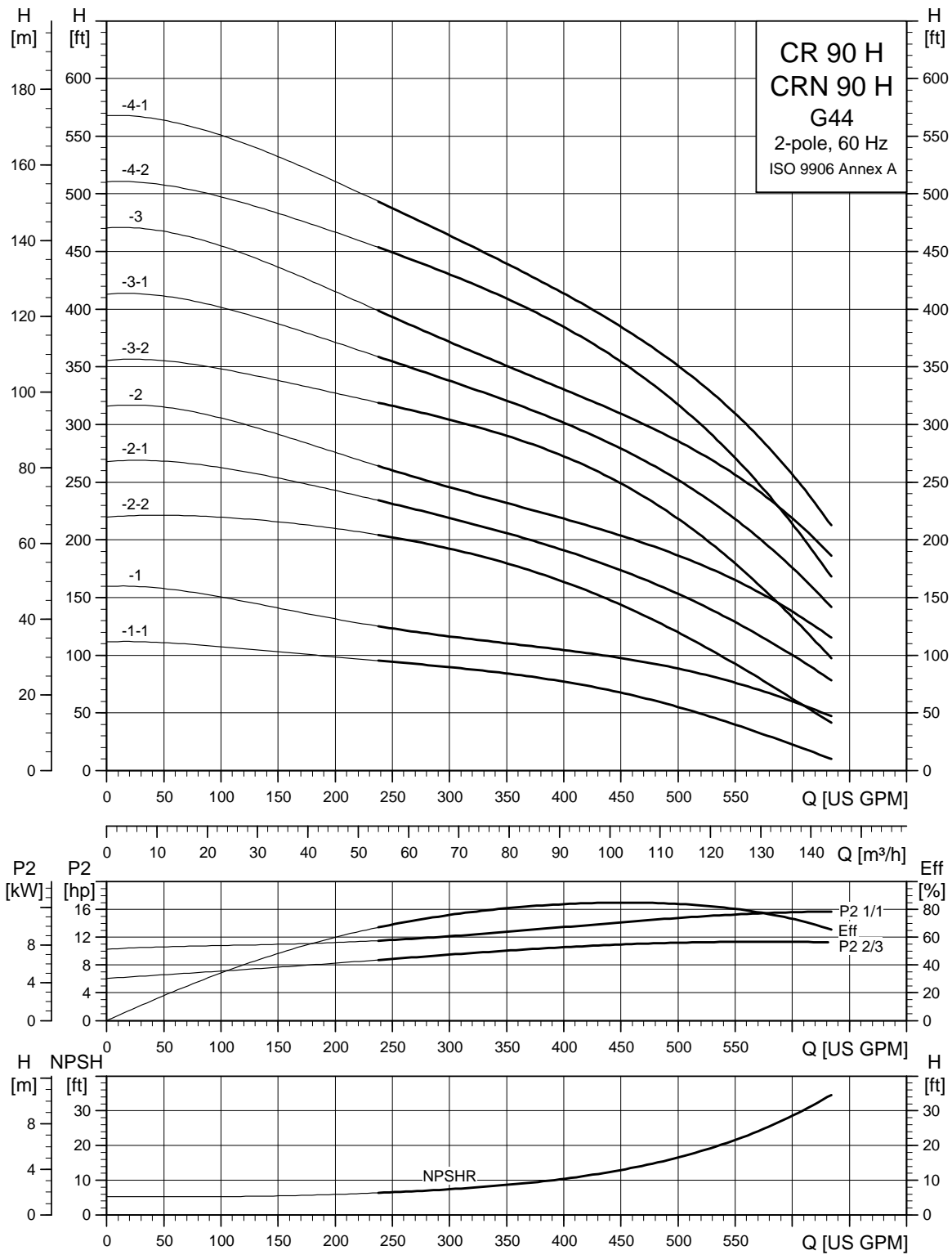

TM04 6306 0912

Dimensions and weights G44 (4" x 4")

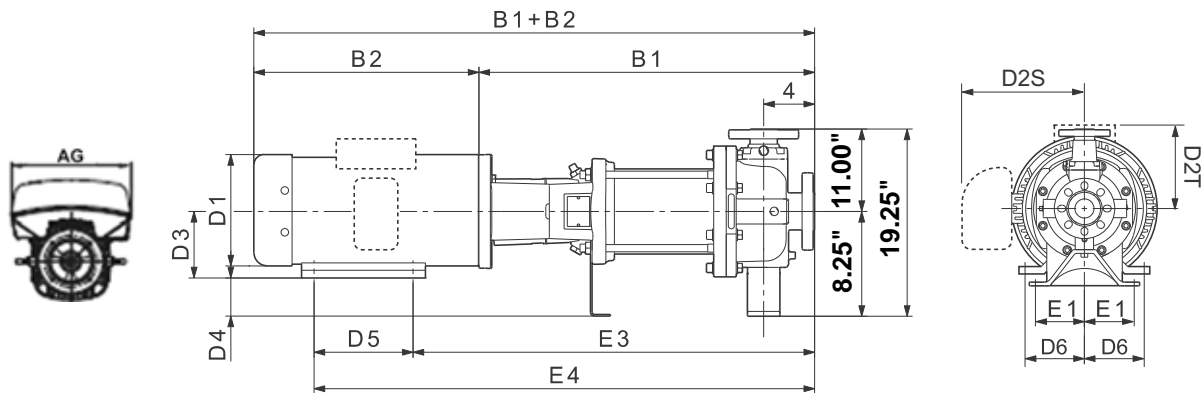

TM06 9699 1014 - TM06 1063 1514

Pump type	HP	PH	Dimensions [in] TEFC													Ship. wt. [lbs]	Dimensions [in] ODP			Dimensions [in] MLE*				Ship. wt. [lbs]
			B1	B1+B2	E1	E3	E4	D1	D2T	D2S	D3	D4	D5	D6	D1		D2	B1+B2	D1	D2	AG	B1+B2		
CR(N) 90-1-1 H	15	3	27.25	45.75	4.88	32.25	40.50	12.38	8.00	-	6.25	2.00	8.25	5.00	554	10.63	8.00	45.38	10.04	9.33	13.62	43.23	508	
CR(N) 90-1 H	20	3	27.25	45.75	4.88	32.25	42.25	12.38	8.00	-	6.25	2.00	10.00	5.00	548	11.50	9.00	45.13	13.39	12.13	16.54	46.03	658	
CR(N) 90-2-2 H	25	3	30.88	53.25	4.88	35.88	45.38	12.38	8.00	-	7.00	1.25	9.50	5.50	586	11.50	11.38	49.88	13.39	12.13	16.54	53.60	698	
CR(N) 90-2-1 H	30	3	30.88	53.25	4.88	35.88	46.88	12.38	8.00	-	7.00	1.25	11.00	5.50	612	11.50	11.38	51.38	13.39	12.13	16.54	53.60	727	
CR(N) 90-2 H	40	3	30.88	54.00	4.88	35.88	46.88	15.00	-	13.13	7.00	1.25	11.00	5.50	863	13.25	12.25	52.00	-	-	-	-	-	
CR(N) 90-3-2 H	40	3	34.50	57.63	4.88	39.50	50.50	15.00	-	13.13	7.00	1.25	11.00	5.50	914	13.25	12.25	55.63	-	-	-	-	-	
CR(N) 90-3-1 H	50	3	34.50	59.88	4.88	40.00	52.00	16.88	-	14.50	8.00	0.25	12.00	6.25	954	13.25	12.25	56.63	-	-	-	-	-	
CR(N) 90-3 H	50	3	34.50	59.88	4.88	40.00	52.00	16.88	-	14.50	8.00	0.25	12.00	6.25	954	13.25	12.25	56.63	-	-	-	-	-	
CR(N) 90-4-2 H	60	3	38.13	65.50	4.88	44.25	56.50	16.88	-	14.63	9.00	-0.75	12.25	7.00	1252	15.13	13.25	62.13	-	-	-	-	-	
CR(N) 90-4-1 H	60	3	38.13	65.50	4.88	44.25	56.50	16.88	-	14.63	9.00	-0.75	12.25	7.00	1252	15.13	13.25	62.13	-	-	-	-	-	

Note: Terminal box is on top of ML motors (through 30 HP). Baldor motors have terminal box on the side (40 HP and larger). Reference D2 dimension. Weights are based on pump with TEFC motor.

\* Dimensions shown for three-phase MLE motors are for 460 V versions.

**CR, CRN 90 H G20**

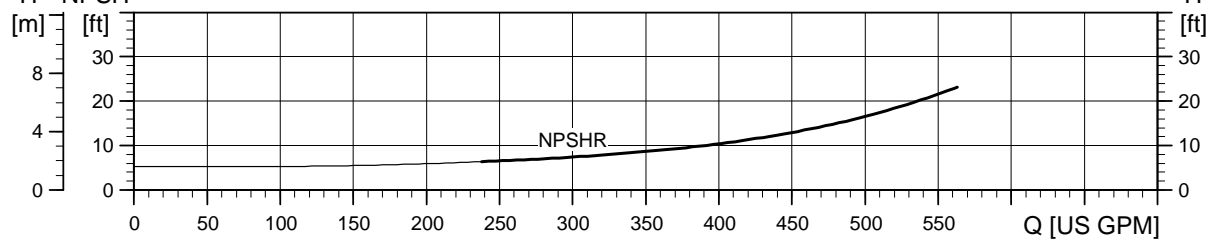
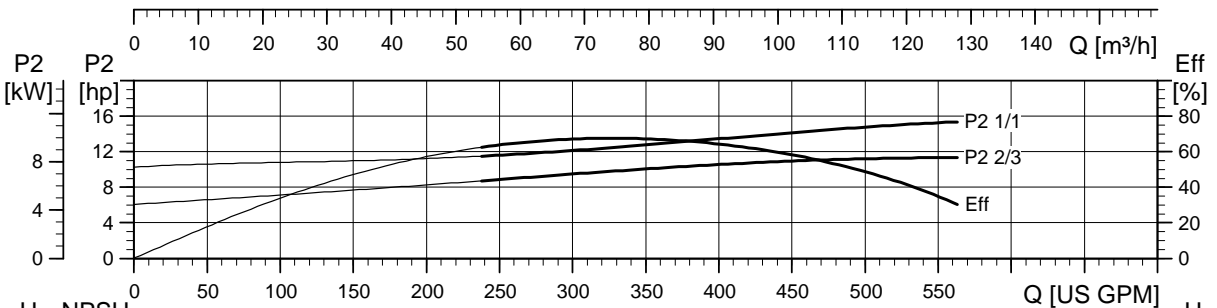
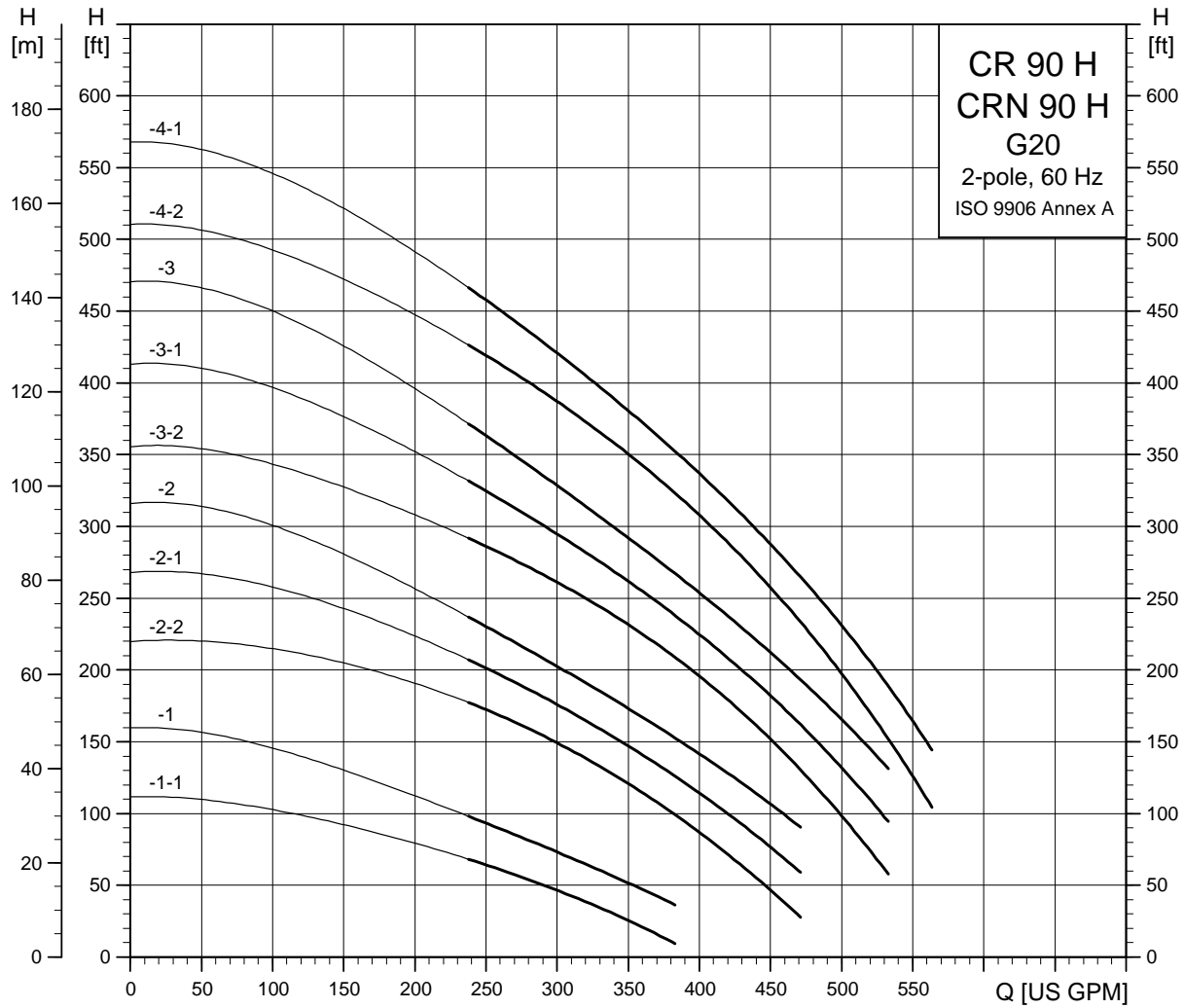

TM04 6303 4610

Dimensions and weights G20 (3" x 1.5" x 13")

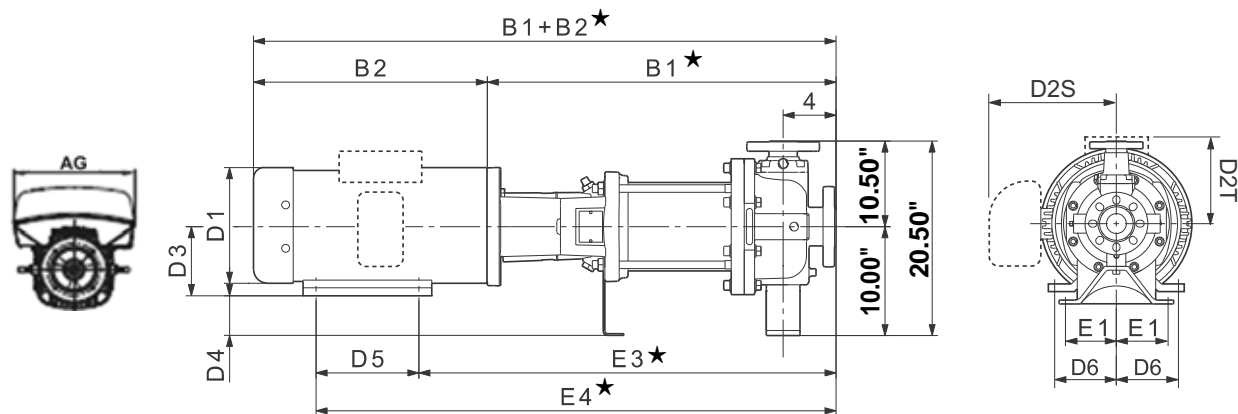

TM06 9699 1014 - TM06 1063 1514

Pump type	HP	PH	Dimensions [in] TEFC													Ship. wt. [lbs]	Dimensions [in] ODP			Dimensions [in] MLE*				Ship. wt. [lbs]
			B1 ★	B1+ B2 ★	E1	E3 ★	E4 ★	D1	D2T	D2S	D3	D4	D5	D6	D1		D2	B1+ B2 ★	D1	D2	AG	B1+ B2 ★		
CR(N) 90-1-1 H	15	3	26.00	44.63	4.88	31.00	39.25	12.38	8.00	-	6.25	3.75	8.25	5.00	527	10.63	8.00	44.25	10.04	9.33	13.62	41.98	482	
CR(N) 90-1 H	20	3	26.00	44.63	4.88	31.00	41.00	12.38	8.00	-	6.25	3.75	10.00	5.00	522	11.50	9.00	44.00	13.39	12.13	16.54	44.78	632	
CR(N) 90-2-2 H	25	3	29.63	52.00	4.88	34.63	44.13	12.38	8.00	-	7.00	3.00	9.50	5.50	550	11.50	11.38	48.75	13.39	12.13	16.54	52.35	663	
CR(N) 90-2-1 H	30	3	29.63	52.00	4.88	34.63	45.63	12.38	8.00	-	7.00	3.00	11.00	5.50	577	11.50	11.38	50.25	13.39	12.13	16.54	52.34	692	
CR(N) 90-2 H	40	3	29.63	52.88	4.88	34.63	45.63	15.00	-	13.13	7.00	3.00	11.00	5.50	828	13.25	12.25	50.88	-	-	-	-	-	
CR(N) 90-3-2 H	40	3	33.25	56.50	4.88	38.25	49.25	15.00	-	13.13	7.00	3.00	11.00	5.50	887	13.25	12.25	54.50	-	-	-	-	-	
CR(N) 90-3-1 H	50	3	33.25	58.75	4.88	38.75	50.75	16.88	-	14.50	8.00	2.00	12.00	6.25	927	13.25	12.25	55.50	-	-	-	-	-	
CR(N) 90-3 H	50	3	33.25	58.75	4.88	38.75	50.75	16.88	-	14.50	8.00	2.00	12.00	6.25	927	13.25	12.25	55.50	-	-	-	-	-	
CR(N) 90-4-2 H	60	3	36.88	64.38	4.88	43.00	55.25	16.88	-	14.63	9.00	1.00	12.25	7.00	1219	15.13	13.25	61.00	-	-	-	-	-	
CR(N) 90-4-1 H	60	3	36.88	64.38	4.88	43.00	55.25	16.88	-	14.63	9.00	1.00	12.25	7.00	1219	15.13	13.25	61.00	-	-	-	-	-	

Note: Terminal box is on top of ML motors (through 30 HP). Baldor motors have terminal box on the side (40 HP and larger). Reference D2 dimension. Weights are based on pump with TEFC motor.

\* Dimensions shown for three-phase MLE motors are for 460 V versions.

★ Add 0.67 inches for CRN-H dimensions.

**CR, CRN 90 H G30/G60**

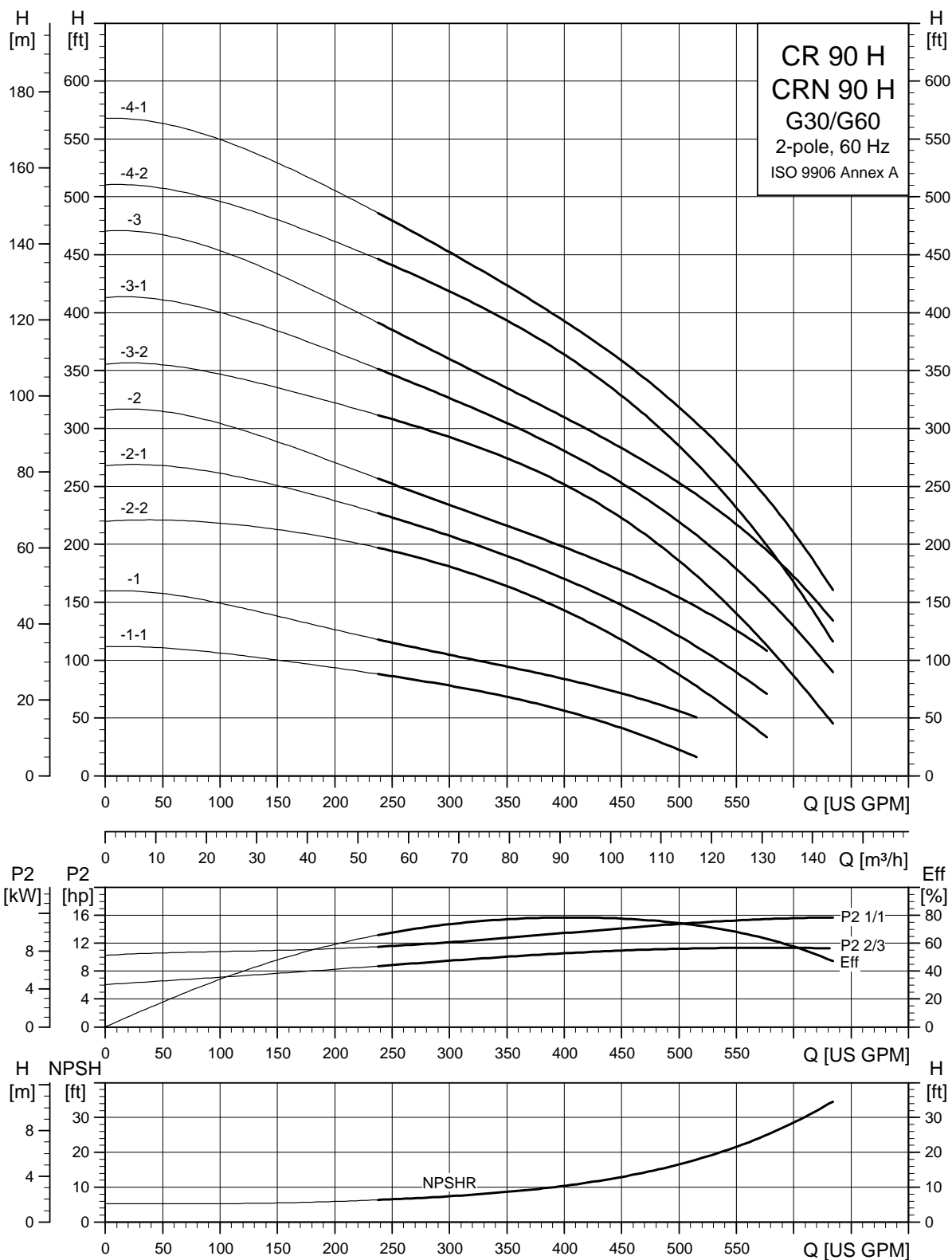

TM04 6304 4610

Dimensions and weights G30 (3" x 2" x 13")

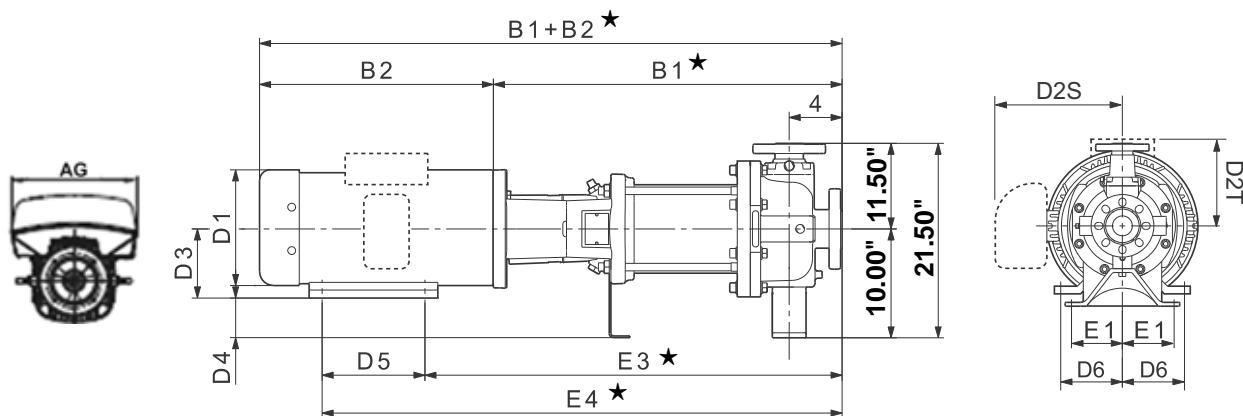

TM06 9699 1014 - TM06 1063 1514

Pump type	HP	PH	Dimensions [in] TEFC													Ship. wt. [lbs]	Dimensions [in] ODP			Dimensions [in] MLE*				Ship. wt. [lbs]
			B1★	B1+B2★	E1	E3★	E4★	D1	D2T	D2S	D3	D4	D5	D6	D1		D2	B1+B2★	D1	D2	AG	B1+B2★		
CR(N) 90-1-1 H	15	3	26.00	44.63	4.88	31.00	39.25	12.38	8.00	-	6.25	3.75	8.25	5.00	554	10.63	8.00	44.25	10.04	9.33	13.62	41.98	508	
CR(N) 90-1 H	20	3	26.00	44.63	4.88	31.00	41.00	12.38	8.00	-	6.25	3.75	10.00	5.00	548	11.50	9.00	44.00	13.39	12.13	16.54	44.78	658	
CR(N) 90-2-2 H	25	3	29.63	52.00	4.88	34.63	44.13	12.38	8.00	-	7.00	3.00	9.50	5.50	586	11.50	11.38	48.75	13.39	12.13	16.54	52.35	698	
CR(N) 90-2-1 H	30	3	29.63	52.00	4.88	34.63	45.63	12.38	8.00	-	7.00	3.00	11.00	5.50	612	11.50	11.38	50.25	13.39	12.13	16.54	52.35	727	
CR(N) 90-2 H	40	3	29.63	52.88	4.88	34.63	45.63	15.00	-	13.13	7.00	3.00	11.00	5.50	863	13.25	12.25	50.88	-	-	-	-	-	
CR(N) 90-3-2 H	40	3	33.25	56.50	4.88	38.25	49.25	15.00	-	13.13	7.00	3.00	11.00	5.50	890	13.25	12.25	54.50	-	-	-	-	-	
CR(N) 90-3-1 H	50	3	33.25	58.75	4.88	38.75	50.75	16.88	-	14.50	8.00	2.00	12.00	6.25	930	13.25	12.25	55.50	-	-	-	-	-	
CR(N) 90-3 H	50	3	33.25	58.75	4.88	38.75	50.75	16.88	-	14.50	8.00	2.00	12.00	6.25	930	13.25	12.25	55.50	-	-	-	-	-	
CR(N) 90-4-2 H	60	3	36.88	64.38	4.88	43.00	55.25	16.88	-	14.63	9.00	1.00	12.25	7.00	1219	15.13	13.25	61.00	-	-	-	-	-	
CR(N) 90-4-1 H	60	3	36.88	64.38	4.88	43.00	55.25	16.88	-	14.63	9.00	1.00	12.25	7.00	1219	15.13	13.25	61.00	-	-	-	-	-	

Note: Terminal box is on top of ML motors (through 30 HP). Baldor motors have terminal box on the side (40 HP and larger). Reference D2 dimension. Weights are based on pump with TEFC motor.

\* Dimensions shown for three-phase MLE motors are for 460 V versions.

★ Add 0.67 inches for CRN-H dimensions.

Dimensions and weights G60 (3" x 2" x 8", 3" x 2" x 10")

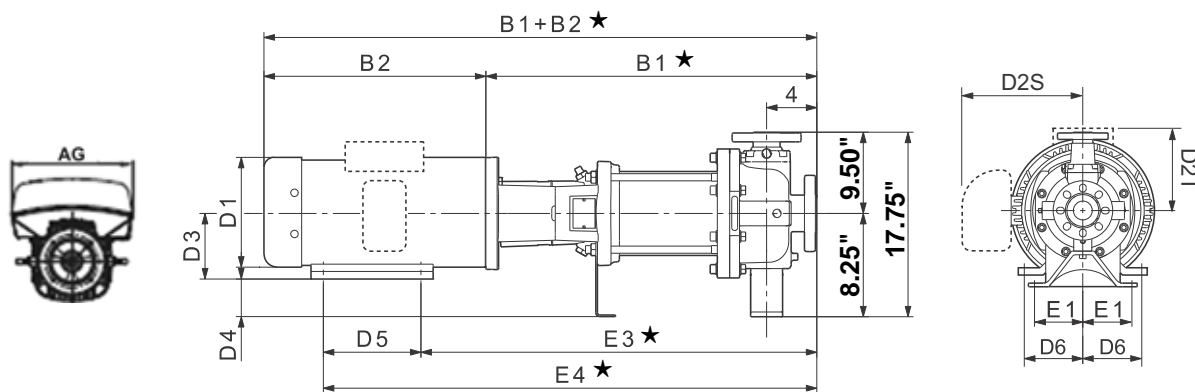

TM06 9699 1014 - TM06 1063 1514

Pump type	HP	PH	Dimensions [in] TEFC												Ship. wt. [lbs]	Dimensions [in] ODP			Dimensions [in] MLE*				Ship. wt. [lbs]
			B1★	B1+B2★	E1	E3★	E4★	D1	D2T	D2S	D3	D4	D5	D6		D1	D2	B1+B2★	D1	D2	AG	B1+B2★	
CR(N) 90-1-1 H	15	3	26.00	44.63	4.88	31.00	39.25	12.38	8.00	-	6.25	2.00	8.25	5.00	536	10.63	8.00	44.25	10.04	9.33	13.62	41.98	491
CR(N) 90-1 H	20	3	26.00	44.63	4.88	31.00	41.00	12.38	8.00	-	6.25	2.00	10.00	5.00	531	11.50	9.00	44.00	13.39	12.13	16.54	44.78	641
CR(N) 90-2-2 H	25	3	29.63	52.00	4.88	34.63	44.13	12.38	8.00	-	7.00	1.25	9.50	5.50	568	11.50	11.38	48.75	13.39	12.13	16.54	52.35	681
CR(N) 90-2-1 H	30	3	29.63	52.00	4.88	34.63	45.63	12.38	8.00	-	7.00	1.25	11.00	5.50	594	11.50	11.38	50.25	13.39	12.13	16.54	52.35	710
CR(N) 90-2 H	40	3	29.63	52.88	4.88	34.63	45.63	15.00	-	13.13	7.00	1.25	11.00	5.50	846	13.25	12.25	50.88	-	-	-	-	-
CR(N) 90-3-2 H	40	3	33.25	56.50	4.88	38.25	49.25	15.00	-	13.13	7.00	1.25	11.00	5.50	898	13.25	12.25	54.50	-	-	-	-	-
CR(N) 90-3-1 H	50	3	33.25	58.75	4.88	38.75	50.75	16.88	-	14.50	8.00	0.25	12.00	6.25	938	13.25	12.25	55.50	-	-	-	-	-
CR(N) 90-3 H	50	3	33.25	58.75	4.88	38.75	50.75	16.88	-	14.50	8.00	0.25	12.00	6.25	938	13.25	12.25	55.50	-	-	-	-	-
CR(N) 90-4-2 H	60	3	36.88	64.38	4.88	43.00	55.25	16.88	-	14.63	9.00	-0.75	12.25	7.00	1226	15.13	13.25	61.00	-	-	-	-	-
CR(N) 90-4-1 H	60	3	36.88	64.38	4.88	43.00	55.25	16.88	-	14.63	9.00	-0.75	12.25	7.00	1226	15.13	13.25	61.00	-	-	-	-	-

Note: Terminal box is on top of ML motors (through 30 HP). Baldor motors have terminal box on the side (40 HP and larger). Reference D2 dimension. Weights are based on pump with TEFC motor.

\* Dimensions shown for three-phase MLE motors are for 460 V versions.

★ Add 0.67 inches for CRN-H dimensions.

**CR, CRN 90 H G40/G70**

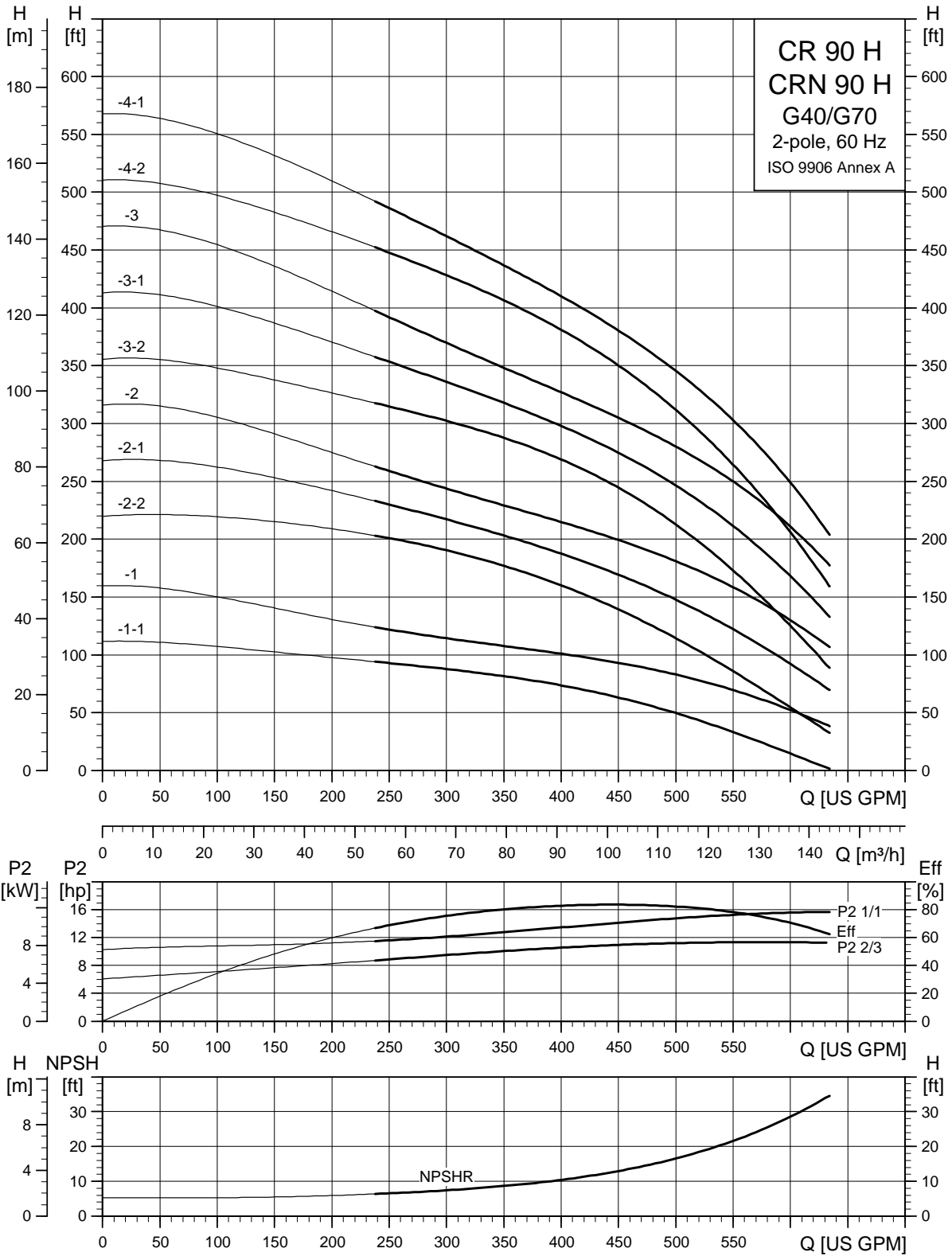

TM04 6305 4610

Dimensions and weights G40 (4" x 3" x 10", 4" x 3" x 13")

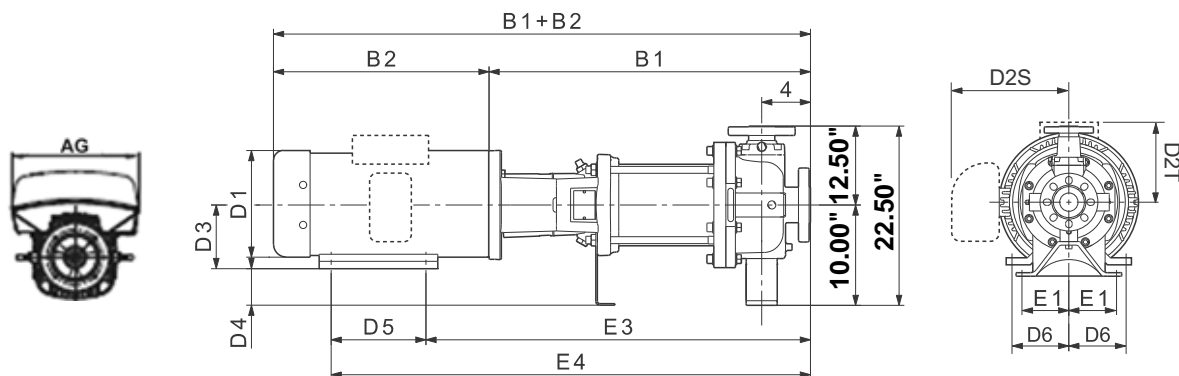

TM06 9699 1014 - TM06 1063 1514

Pump type	HP	PH	Dimensions [in] TEFC													Dimensions [in] ODP			Dimensions [in] MLE*				Ship. wt. [lbs]
			B1	B1+B2	E1	E3	E4	D1	D2T	D2S	D3	D4	D5	D6	D1	D2	B1+B2	D1	D2	AG	B1+B2		
CR(N) 90-1-1 H	15	3	27.25	45.75	4.88	32.25	40.50	12.38	8.00	-	6.25	3.75	8.25	5.00	591	10.63	8.00	45.38	10.04	9.33	13.62	43.23	546
CR(N) 90-1 H	20	3	27.25	45.75	4.88	32.25	42.25	12.38	8.00	-	6.25	3.75	10.00	5.00	586	11.50	9.00	45.13	13.39	12.13	16.54	46.03	696
CR(N) 90-2-2 H	25	3	30.88	53.25	4.88	35.88	45.38	12.38	8.00	-	7.00	3.00	9.50	5.50	623	11.50	11.38	49.88	13.39	12.13	16.54	53.60	736
CR(N) 90-2-1 H	30	3	30.88	53.25	4.88	35.88	46.88	12.38	8.00	-	7.00	3.00	11.00	5.50	649	11.50	11.38	51.38	13.39	12.13	16.54	53.60	765
CR(N) 90-2 H	40	3	30.88	54.00	4.88	35.88	46.88	15.00	-	13.13	7.00	3.00	11.00	5.50	901	13.25	12.25	52.00	-	-	-	-	-
CR(N) 90-3-2 H	40	3	34.50	57.63	4.88	39.50	50.50	15.00	-	13.13	7.00	3.00	11.00	5.50	925	13.25	12.25	55.63	-	-	-	-	-
CR(N) 90-3-1 H	50	3	34.50	59.88	4.88	40.00	52.00	16.88	-	14.50	8.00	2.00	12.00	6.25	965	13.25	12.25	56.63	-	-	-	-	-
CR(N) 90-3 H	50	3	34.50	59.88	4.88	40.00	52.00	16.88	-	14.50	8.00	2.00	12.00	6.25	965	13.25	12.25	56.63	-	-	-	-	-
CR(N) 90-4-2 H	60	3	38.13	65.50	4.88	44.25	56.50	16.88	-	14.63	9.00	1.00	12.25	7.00	1261	15.13	13.25	62.13	-	-	-	-	-
CR(N) 90-4-1 H	60	3	38.13	65.50	4.88	44.25	56.50	16.88	-	14.63	9.00	1.00	12.25	7.00	1261	15.13	13.25	62.13	-	-	-	-	-

Note: Terminal box is on top of ML motors (through 30 HP). Baldor motors have terminal box on the side (40 HP and larger). Reference D2 dimension. Weights are based on pump with TEFC motor.

\* Dimensions shown for three-phase MLE motors are for 460 V versions.

Dimensions and weights G70 (4" x 3" x 8", 4" x 3" x 10")

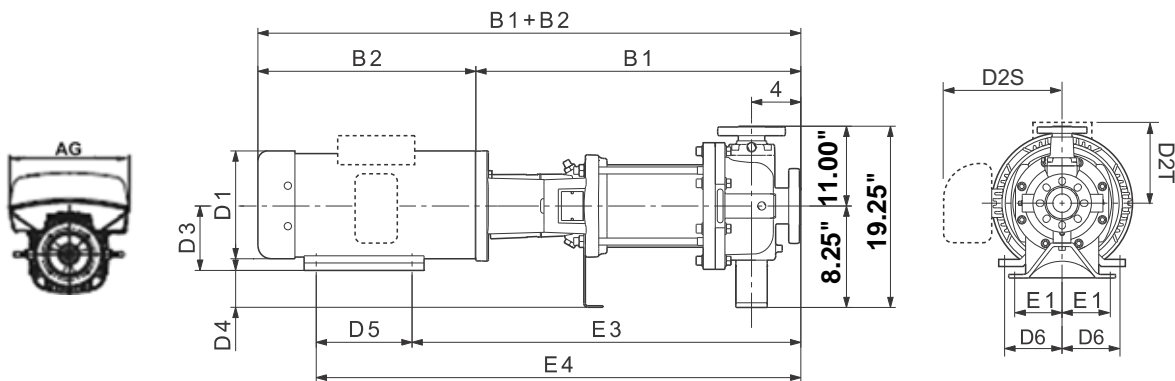

TM06 9699 1014 - TM06 1063 1514

Pump type	HP	PH	Dimensions [in] TEFC													Ship. wt. [lbs]	Dimensions [in] ODP			Dimensions [in] MLE*				Ship. wt. [lbs]
			B1	B1+B2	E1	E3	E4	D1	D2T	D2S	D3	D4	D5	D6	D1		D2	B1+B2	D1	D2	AG	B1+B2		
CR(N) 90-1-1 H	15	3	27.25	45.75	4.88	32.25	40.50	12.38	8.00	-	6.25	2.00	8.25	5.00	448	10.63	8.00	45.38	10.04	9.33	13.62	43.23	403	
CR(N) 90-1 H	20	3	27.25	45.75	4.88	32.25	42.25	12.38	8.00	-	6.25	2.00	10.00	5.00	443	11.50	9.00	45.13	13.39	12.13	16.54	46.03	553	
CR(N) 90-2-2 H	25	3	30.88	53.25	4.88	35.88	45.38	12.38	8.00	-	7.00	1.25	9.50	5.50	480	11.50	11.38	49.88	13.39	12.13	16.54	53.60	593	
CR(N) 90-2-1 H	30	3	30.88	53.25	4.88	35.88	46.88	12.38	8.00	-	7.00	1.25	11.00	5.50	506	11.50	11.38	51.38	13.39	12.13	16.54	53.60	622	
CR(N) 90-2 H	40	3	30.88	54.00	4.88	35.88	46.88	15.00	-	13.13	7.00	1.25	11.00	5.50	758	13.25	12.25	52.00	-	-	-	-	-	
CR(N) 90-3-2 H	40	3	34.50	57.63	4.88	39.50	50.50	15.00	-	13.13	7.00	1.25	11.00	5.50	808	13.25	12.25	55.63	-	-	-	-	-	
CR(N) 90-3-1 H	50	3	34.50	59.88	4.88	40.00	52.00	16.88	-	14.50	8.00	0.25	12.00	6.25	848	13.25	12.25	56.63	-	-	-	-	-	
CR(N) 90-3 H	50	3	34.50	59.88	4.88	40.00	52.00	16.88	-	14.50	8.00	0.25	12.00	6.25	848	13.25	12.25	56.63	-	-	-	-	-	
CR(N) 90-4-2 H	60	3	38.13	65.50	4.88	44.25	56.50	16.88	-	14.63	9.00	-0.75	12.25	7.00	1133	15.13	13.25	62.13	-	-	-	-	-	
CR(N) 90-4-1 H	60	3	38.13	65.50	4.88	44.25	56.50	16.88	-	14.63	9.00	-0.75	12.25	7.00	1133	15.13	13.25	62.13	-	-	-	-	-	

Note: Terminal box is on top of ML motors (through 30 HP). Baldor motors have terminal box on the side (40 HP and larger). Reference D2 dimension. Weights are based on pump with TEFC motor.

\* Dimensions shown for three-phase MLE motors are for 460 V versions.

## 14. Motor data

### Motors for CR(E)-H, CRN(E)-H

Motors used in the CR(E)-H, CRN(E)-H pump range are:

- Grundfos ML or MLE motors
- Grundfos-specified **Baldor®** motors

The information in the tables below applies to the following motors type and size:

Type	PH	Motor range [HP]	Cooling
ML	3	1/3 - 30	TEFC
	1	1/3 - 10	TEFC
Baldor	3	40-60	TEFC
	3	15-60	ODP
MLE	1	1/2 - 2	TEFC
	3	1-30	TEFC

Grundfos CR(E)-H, CRN(E)-H pumps are supplied with 2-pole, NEMA C-frame motors built or selected to our rigid specifications. All CR(E)-H, CRN(E)-H pump motors have heavy-duty bearings for maximum thrust requirements.

We do not recommend that an off-the-shelf standard Baldor motor is used on a Grundfos pump. Ideally, the best motor choice would be the Grundfos-specified motor.

Other motor types are available (i.e. explosion-proof, Mill and Chem Duty, high efficiency, etc.); consult your local Grundfos company for more information.

Pumps supplied by Grundfos Canada are normally supplied with motors from other manufacturers. The 575 V motors also meet NEMA Premium efficiency standards. Dimensions and data will vary; contact your local Grundfos company for more information.

All values are subject to change without notice.

Grundfos ML motor



GR 7845

Baldor motor



TM04 6540 0510

Grundfos MLE motor



GR 8972\_P

TEFC motors (totally enclosed fan cooled, constant speed)

Product number	HP	PH	Frame size	SF	Supply voltage [V]	Eff. [%]	Efficiency rating	Temp class	KVA	FLA	SFA	LRA	Motor
84Z04526	1/3	1	56C	1.35	115/230	55	Not defined	B	K	6/3	7.6 / 3.8	28/14	Baldor
97567717	1/3	3	56C	1.35	208-230/460	78.5	Not defined	F	A	1.12 - 1.1 / 0.55	1.5 - 1.45 / 0.75	7.1 - 7.7 / 3.9	ML
84Z04527	1/2	1	56C	1.60	115/208-230	62	Not defined	B	K	7.4 / 4.1 - 3.7	9.8 / 5.2 - 4.9	39 / 21.6 - 19.5	Baldor
97568081	1/2	3	56C	1.25	208-230/460	78.5	Not defined	F	K	1.64 - 1.55 / 0.78	2.0 - 1.9 / 0.95	9.7 - 10.1 / 5.1	ML
84Z04528	3/4	1	56C	1.25	115/230	66	Not defined	B	K	9.6 / 4.8	11.4 / 6	56 / 31-28	Baldor
97678090	3/4	3	56C	1.25	208-230/460	80	Not defined	F	J	2.4 - 2.3 / 1.2	2.9 - 2.75 / 1.4	14.2 - 15.0 / 7.8	ML
84Z04529	1	1	56C	1.25	115/230	66	Not defined	B	K	12 / 6	14.4 / 7.2	77 / 38.5	Baldor
97568102	1	3	56C	1.25	208-230/460	80	NEMA Premium	F	K	3.25 - 3.35 / 1.68	4.0 - 3.9 / 1.95	19.2 - 21.8 / 11.0	ML
84Z04530	1 1/2	1	56C	1.30	115/208-230	71	Not defined	B	K	17 / 9.5 - 8.6	20.4 / 11.3 - 10.2	106 / 58.6 - 53	Baldor
97568103	1 1/2	3	56C	1.15	208-230/460	84	NEMA Premium	F	L	4.7 - 4.6 / 2.3	5.2 - 5.1 / 2.55	33.9 - 36.8 / 18.4	ML
84Z04531	2	1	56C	1.15	115/208-230	74	Not defined	B	K	23 / 12.7 - 11.5	25.4 / 12.7 - 12.7	156/78	Baldor
97568104	2	3	56C	1.15	208-230/460	85.5	NEMA Premium	F	M	5.7 - 5.4 / 2.7	6.55 - 6.1 / 3.05	46.2 - 48.6 / 24.3	ML
84Z04532	3	1	182TC	1.15	115/208-230	75	Not defined	F	H	29 / 16 - 14.5	31.8 / 18 - 15.9	172/95-86	Baldor
97568105	3	3	182TC	1.15	208-230/460	86.5	NEMA Premium	F	M	8.4 - 7.7 / 3.9	9.5 - 8.6 / 4.3	79.0 - 80.1 / 40.6	ML
84Z04533	5	1	213TC	1.15	230	80	Not defined	F	J	22	25	170	Baldor
97568106	5	3	182TC	1.15	208-230/460	88.5	NEMA Premium	F	M	13.8 - 13.0 / 6.5	15.6 - 14.6 / 7.3	124.2 - 128.7 / 64.4	ML
84Z04534	7 1/2	1	213TC	1.15	208-230	82	Not defined	F	F	33.8 - 31	35.5 - 33.8	244-220	Baldor
97568109	7 1/2	3	213TC	1.15	208-230/460	90	NEMA Premium	F	N	20.4 - 19.4 / 9.7	23 - 21.5 / 10.8	191.8 - 201.8 / 100.9	ML
84Z04535	10	1	213TC	1.15	230	85.5	Not defined	F	F	40	46	284	Baldor
97568110	10	3	213TC	1.15	208-230/460	90.2	NEMA Premium	F	M	26.5 - 25.5 / 12.8	30.5 - 28.5 / 14.5	238.5 - 252.5 / 126.8	ML
84Z04951	15	3	254TCZ	1.15	230/460	91	NEMA Premium	F	K	34.4 / 17.2	40/20	336-304/152	Baldor
84Z04952	20	3	256TCZ	1.15	230/460	91	NEMA Premium	F	H	46/23	52/26	412/206	Baldor
84Z04953	25	3	284TSCZ	1.15	230/460	93	NEMA Premium	F	J	56/28	63/31.5	502-454/227	Baldor
84Z04954	30	3	286TSCZ	1.15	230/460	93	NEMA Premium	F	J	66/33	76/38	495-448/224	Baldor
84Z04955	40	3	286TSCZ	1.15	230/460	93.6	NEMA Premium	F	L	90/45	104/52	728-658/329	Baldor
84Z04957	50	3	326TSCZ	1.15	230/460	93	NEMA Premium	F	H	112/56	128/64	810/405	Baldor
84Z04958	60	3	364TSCZ	1.15	230/460	93.6	NEMA Premium	F	J	136/68	154/77	950/475	Baldor

We recommend that you verify all electrical data for motors on the motor nameplate.

## ODP Motors (open drip proof, constant speed)

Product number	Power [HP]	PH	Frame size	SF	Supply voltage [V]	Eff. [%]	Efficiency rating	Temp. class	KVA	FLA	SFA	LRA	Motor
84Z04963	15	3	254TCZ	1.15	230/460	91	NEMA Premium	F	J	34/17	39.8 / 18.9	272/136	Baldor
84Z04964	20	3	254TCZ	1.15	230/460	91	NEMA Premium	F	G	48/24	54/27	306/153	Baldor
84Z04965	25	3	286TSCZ	1.15	230/460	91.7	NEMA Premium	F	G	56/28	34/32	374/187	Baldor
84Z04966	30	3	284TSCZ	1.15	230/460	91.7	NEMA Premium	F	F	66/33	76/38	480/240	Baldor
84Z04967	40	3	286TSCZ	1.15	230/460	94.1	NEMA Premium	F	H	90/45	104/52	542/271	Baldor
84Z04968	50	3	324TSCZ	1.15	230/460	94.5	NEMA Premium	F	J	108/54	124/62	542/271	Baldor
84Z04969	60	3	326TSCZ	1.15	230/460	94.5	NEMA Premium	F	H	130/165	148/74	542/271	Baldor

## MLE Motors (integrated variable frequency drive)

HP	Voltage [V]	PH	NEMA frame Size	Service factor	Motor full load efficiency [%]	Full load current amps** [A]	Service factor current amps [A]	Power factor	Full load speed [rpm]	Sound pressure level [dB(A)]
1/2 <sup>1)</sup>	200-240	1	56C	1	84*	2.40 - 2.10	-	0.96	3400	58
3/4 <sup>1)</sup>	200-240	1	56C	1	85.3*	3.45 - 2.90	-	0.98	3400	58
1 <sup>1)</sup>	200-240	1	56C	1	85.2*	4.70 - 3.90	-	0.99	3400	58
1 <sup>1)</sup>	440-480	3	56C	1.25	86.4*	1.65	2.10	0.73	3480	58
1 1/2 <sup>1)</sup>	200-240	1	56C	1	86.9*	6.70 - 5.60	-	0.99	3400	58
1 1/2 <sup>1)</sup>	200-240	3	56C	1.15	89.3*	4.00 - 3.40	4.60 - 3.90	0.91	3480	55
1 1/2 <sup>1)</sup>	440-480	3	56C	1.15	89.6*	2.05	2.40	0.84	3480	58
2 <sup>1)</sup>	200-240	1	56C	1	87.4*	9.10 - 7.60	-	0.99	3400	64
2 <sup>1)</sup>	200-240	3	56C	1.00	88.90*	5.40 - 4.50	-	0.92	3480	55
2 <sup>1)</sup>	440-480	3	56C	1.15	89.4*	2.65	3.00	0.87	3480	64
3 <sup>1)</sup>	200-240	3	182TC	1.15	88.70*	7.90 - 6.60	9.10 - 7.60	0.94	3480	62
3 <sup>1)</sup>	440-480	3	182TC	1.15	90.7*	3.8	4.30	0.89	3480	64
5 <sup>1)</sup>	200-240	3	182TC	1.15	90.90*	13.2 - 10.9	14.90 - 12.40	0.94	3480	66
5 <sup>1)</sup>	440-480	3	182TC	1.15	92.5*	6.20 - 5.80	7.00 - 6.60	0.90	3500	60
7 1/2 <sup>1)</sup>	200-240	3	213TC	1.15	90.20 *	20.0 - 16.6	23.0 - 19.3	0.94	3480	70
7 1/2 <sup>1)</sup>	440-480	3	213TC	1.15	92.4*	9.10 - 8.50	10.4 - 9.70	0.91	3500	60
10 <sup>1)</sup>	440-480	3	213TC	1.15	92.5*	12.4 - 11.5	14.2 - 13.0	0.91	3500	65
15 <sup>1)</sup>	440-480	3	254TC	1.15	93.2*	17.9 - 16.6	20.5 - 19.0	0.92	3500	65
20 <sup>2)</sup>	460-480	3	256TC	1.15	91	24.00	27.50	0.89	3540	68
25 <sup>2)</sup>	460-480	3	284TC	1.15	91.7	30.50	35.00	0.88	3540	70
30 <sup>2)</sup>	460-480	3	286TC	1.15	91.7	36.50	42.00	0.88	3540	70

1) Permanent-magnet motor

2) Asynchronous motor

\* Efficiency of motor and VFD

\*\* At 460 volts for 460-480 volt motors

# 15. Accessories

## Baseplate

Grundfos CR(E)-H, CRN(E)-H baseplates can be selected by using the information on the following pages. Once you have selected your pump you can use the pump data to select the proper baseplate and motor mounting kit. You will need to know the flange connection code, motor frame size and the E4 pump length.

Based on this information you can select your baseplate and motor mounting kit number.

You will need to make sure that your pump length will fit on the standard baseplate by comparing the E4 - 4" dimension to the maximum pump length. If it will not, you can select the long baseplate (XLBP). The XLBP baseplates are longer than ANSI B73.1 baseplates but have floor mounting holes at the standard lengths.

XLBP baseplates also have additional holes near the end as shown in the dimensional table.

The baseplates are constructed from ASTM A36 steel alloy.

**Baseplate dimensional sketch, CR(E), CRN(E) 1s, 1, 3, 5 H**

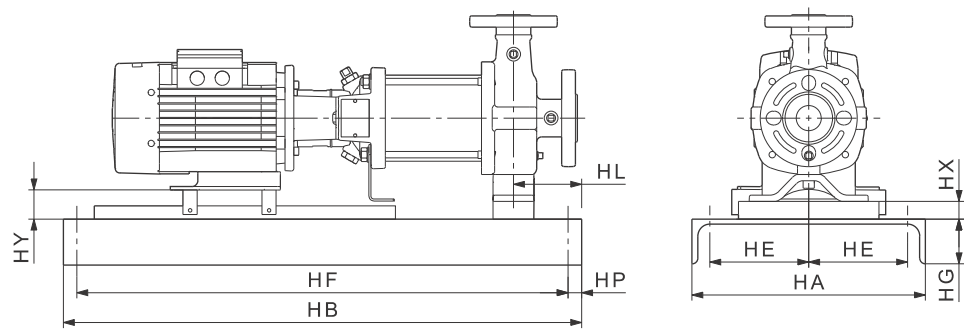

TM04 4639 1809

**Baseplate dimensional sketch, CR(E), CRN(E) 10, 15, 20 H**

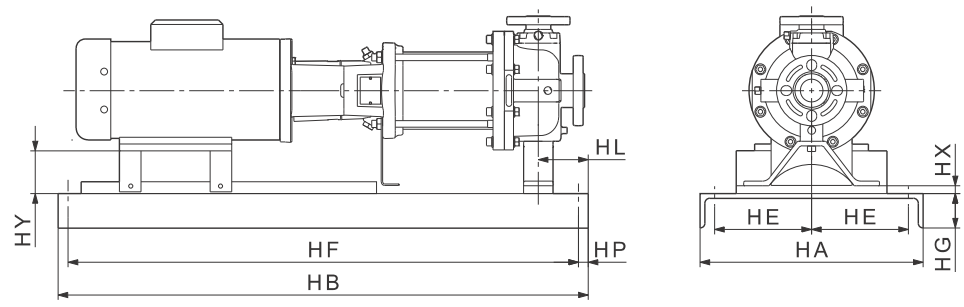

TM04 4640 1809

**Baseplate dimensional sketch, CR(E), CRN(E) 32, 45, 64, 90 H**

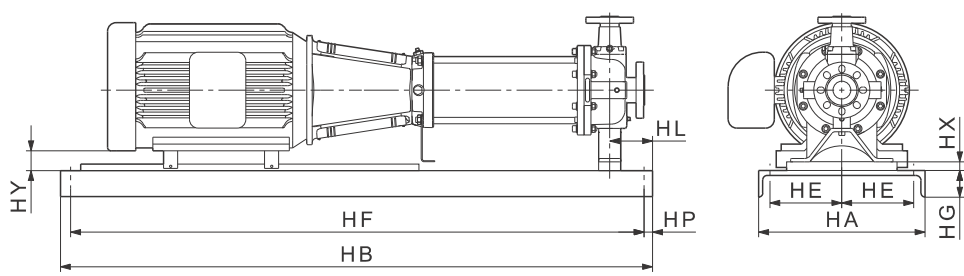

TM04 4641 1809

## Baseplate selection

Baseplate number	NEMA frame	Flange size	CR(E), CRN(E) 1s H to CR 20 H max. pump length (E4 is the inlet flange to rear motor foot line) <sup>1)</sup> [inches]	CR(E), CRN(E) 32 H to 64 H, CR 90 H max. pump length (foot to rear motor hole) <sup>1)</sup> [inches]
139	56T-182T	GA, GB, GC	27.5	23.5
148	213T-256T	GA, GB, GC	37	33
153	286T-364T	GA, GB, GC	42	38
245	56T-182T	G05-G70	34.5	30.5
252	213T	G05-G70	40.5	36.5
258	254T-286T	G05-G70	46.5	42.5
264	324T-364T	G05-G70	53	49
XLBP1 <sup>2, 3)</sup>	56T-182T	139, 245 BP	4)	4)
XLBP2 <sup>2, 3)</sup>	213T-256T	148, 252 BP	4)	4)
XLBP3 <sup>2, 3)</sup>	254T-364T	258, 264 BP	4)	4)
XLBP4 <sup>2, 3)</sup>	284T-364T	153 BP	4)	4)

## Notes

1. If E4 - 4" > maximum pump length, select XLBP (dimensions are in inches).
2. XLBP1 = longer version of 139 and 245 baseplate  
XLBP2 = longer version of 148 and 252 baseplate  
XLBP3 = longer version of 258 and 264 baseplate  
XLBP4 = longer version of 153 baseplate
3. HF on long baseplate versions has bolt holes to use existing ANSI anchor bolts as well as additional bolt holes 1 1/4" from the end.
4. These long baseplates will accommodate all oversize pumps as listed.

## Baseplate dimensions and weight

Baseplate number	NEMA	Flange size	HA	HB	HE	HF <sup>3)</sup>	HG	Bolt hole diameter	HL	HP	HX NEMA	HY NEMA
139	56T	GA, GB, GC	12	39	4.5	36.5	3	0.75	4.5	1.25	0.75	2.50
	182T	GA, GB, GC	12	39	4.5	36.5	3	0.75	4.5	1.25	0.75	1.50
148	213T	GA, GB, GC	15	48	6	45.5	3.5	0.75	4.5	1.25	0.88	0.88
	256T	GA, GB, GC	15	48	6	45.5	3.5	0.75	4.5	1.25	1.88	0.88
153	286T	GA, GB, GC	18	53	7.5	50.5	4	0.75	4.5	1.25	3.63	1.88
	324T	GA, GB, GC	18	53	7.5	50.5	4	0.75	4.5	1.25	3.63	0.88
	364T	GA, GB, GC	18	53	7.5	50.5	4	0.75	4.5	1.25	5.06	1.31
245	56T	G05, G10, G50, G60, G70, G22, G33, G44	12	45	4.5	42.5	3	0.75	4.5	1.25	0.75	5.50
	56T	G20, G30, G40	12	45	4.5	42.5	3	0.75	4.5	1.25	0.75	7.25
	182T	G05, G10, G50, G60, G70, G22, G33, G44	12	45	4.5	42.5	3	0.75	4.5	1.25	0.75	4.50
	182T	G20, G30, G40	12	45	4.5	42.5	3	0.75	4.5	1.25	0.75	6.25
252	213T	G05, G10, G50, G60, G70, G22, G33, G44	15	52	6	49.5	3.5	0.75	4.5	1.25	0.88	3.88
	213T	G20, G30, G40	15	52	6	49.5	3.5	0.75	4.5	1.25	0.88	5.63
258	254T	G05, G10, G50, G60, G70, G22, G33, G44	18	58	7.5	55.5	4	1	4.5	1.25	0.69	2.69
	254T	G20, G30, G40	18	58	7.5	55.5	4	1	4.5	1.25	0.69	4.44
	286T	G05, G10, G50, G60, G70, G22, G33, G44	18	58	7.5	55.5	4	1	4.5	1.25	0.69	1.94
	286T	G20, G30, G40	18	58	7.5	55.5	4	1	4.5	1.25	0.69	3.69
264	324T	G05, G10, G50, G60, G70, G22, G33, G44	18	64	7.5	61.5	4	1	4.5	1.25	1.31	1.56
	324T	G20, G30, G40	18	64	7.5	61.5	4	1	4.5	1.25	1.31	3.31
	364T	G05, G10, G50, G60, G70, G22, G33, G44	18	64	7.5	61.5	4	1	4.5	1.25	2.31	2.56
	364T	G20, G30, G40	18	64	7.5	61.5	4	1	4.5	1.25	1.31	2.31
XLBP1	56-182T	139, 245 BP	12	59	These dimensions will be the same as the baseplate number they are replacing above.							
XLBP2	213-256T	148, 252 BP	15	70	The overall length is longer to accommodate longer pumps.							
XLBP3	254T-364T	258, 264 BP	18	94.75	See notes 1 to 4 below.							
XLBP4	284T-364T	153 BP	18	94.75								

All dimensions are in inches.

## Notes

- If E4 - 4" > maximum pump length, select XLBP (dimensions are in inches).
- XLBP1 = longer version of 139 and 245 baseplate  
XLBP2 = longer version of 148 and 252 baseplate  
XLBP3 = longer version of 258 and 264 baseplate  
XLBP4 = longer version of 153 baseplate
- HF on long baseplate versions has bolt holes to use existing ANSI anchor bolts as well as additional bolt holes 1 1/4" from the end.
- These long baseplates will accommodate all oversize pumps as listed.

## Baseplate and motor mounting kits

Baseplate	Kit description	Product number	Ship weight [lbs]
BP 139	Kit, BP139 56T GA/B/C	97534517	122
	Kit, BP139 182T GA/B/C	97534518	118
BP 148	Kit, BP148 213T GA/B/C	97534520	190
	Kit, BP148 254T GA/B/C	97534531	200
BP 153	Kit, BP153 284T GA/B/C	97534532	272
	Kit, BP153 324T GA/B/C	97534533	264
BP 245	Kit, BP153 364T GA/B/C	97534534	284
	Kit, BP245 56T G05/10/50/60/70/22/33/44	97534535	152
BP 245	Kit, BP245 182T G05/10/50/60/70/22/33/44	97534536	150
	Kit, BP245 56T G20/30/40	97534537	162
	Kit, BP245 182T G20/30/40	97534538	160
BP 252	Kit, BP252 213T G05/10/50/60/70/22/33/44	97534539	222
	Kit, BP252 213T G20/30/40	97534540	228
BP 258	Kit, BP258 254T G05/10/50/60/70/22/33/44	97534543	299
	Kit, BP258 284T G05/10/50/60/70/22/33/44	97534544	287
	Kit, BP258 254T G20/30/40	97534545	307
	Kit, BP258 284T G20/30/40	97534546	307
BP 264	Kit, BP264 324T G05/10/50/60/70/22/33/44	97534548	332
	Kit, BP264 364T G05/10/50/60/70/22/33/44	97534550	356
	Kit, BP264 324T G20/30/40	97534571	332
	Kit, BP264 364T G20/30/40	97534572	334
XLBP1	Kit, BP139 56T GA/B/C	97534573	167
	Kit, BP139 182T GA/B/C	97534574	163
	Kit, BP245 56T G05/10/50/60/70/22/33/44	97534575	180
	Kit, BP245 182T G05/10/50/60/70/22/33/44	97534576	178
	Kit, BP245 56T G20/30/40	97534577	190
	Kit, BP245 182T G20/30/40	97534578	188
XLBP2	Kit, BP148 213T GA/B/C	97573875	262
	Kit, BP148/252 254T GA/B/C	97534579	275
	Kit, BP252 213T G05/10/50/60/70/22/33/44	97573873	278
	Kit, BP252 213T G20/30/40	97573874	284
XLBP3	Kit, BP258/264 254T G05/10/50/60/70/22/33/44	97573876	461
	Kit, BP258/264 284T G05/10/50/60/70/22/33/44	97573877	449
	Kit, BP258/264 254T G20/30/40	97573878	469
	Kit, BP258/264 284T G20/30/40	97573879	469
	Kit, BP258/264 324T G05/10/50/60/70/22/33/44	97534580	461
	Kit, BP258/264 364T G05/10/50/60/70/22/33/44	97534591	470
XLBP4	Kit, BP258/264 324T G20/30/40	97534592	476
	Kit, BP258/264 364T G20/30/40	97534593	463
	Kit, BP153 284T GA/B/C	97534594	453
	Kit, BP153 324T GA/B/C	97534595	445
	Kit, BP153 364T GA/B/C	97534596	465

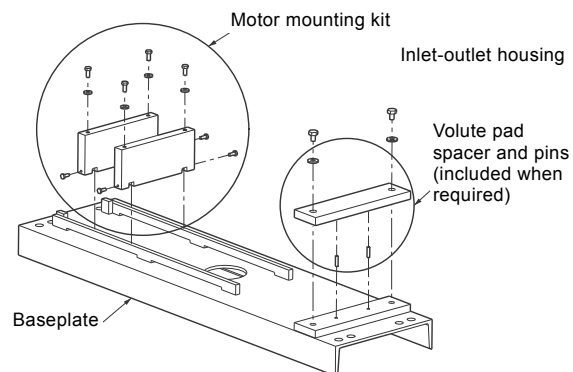

Fig. 63 Baseplate and motor mounting kit

TM04 4805 2109

## Pipe connection

Various sets of counterflanges are available for pipe connection.

### Counterflanges for CR(E)-H, CRN(E)-H

A set consists of two counterflanges, two gaskets, bolts and nuts.

Pump type	Pipe connection (inlet and outlet)	Cast iron press. class	Product number	AISI 316 SS Press. class	Product number
GA	1.5" x 1" NPT		97642565		97698645
G05	2" x 1" NPT		97642567		97698647
GB, G50, G20	3" x 1.5" NPT		97642571		97698649
GC, G10, G60, G30	3" x 2" NPT	Threaded ANSI 125 lb.	97642574	Threaded ANSI 150 lb.	97698651
G70, G40	4" x 3" NPT		97642576		97698653
G22	2" x 2" NPT		97642568		97743809
G33	3" x 3" NPT		559601		91121953
G44	4" x 4" NPT		579801		01D00148
GA	1.5" x 1" NPT		96967594		97698646
G05	2" x 1" NPT		96967595		97698648
GB, G50, G20	3" x 1.5" NPT		97658571		97698650
GC, G10, G60, G30	3" x 2" NPT	Threaded ANSI 250 lb.	97658572	Threaded ANSI 300 lb.	97698652
G70, G40	4" x 3" NPT		97658574		97698654
G22	2" x 2" NPT		97757976		97743810
G33	3" x 3" NPT		97658573		97743812
G44	4" x 4" NPT		360028		97822330

The 3" and 4" 125/150 lb. flanges and the 4" 250/300 lb. flanges on the pumps are standard through-hole ANSI flanges. All other CR(E)-H, CRN(E)-H pump flanges are threaded and will require shorter than standard bolts. Recommended bolt sizes are shown below.

Press. class	Flange size	Qty. bolts	Required bolts	Standard hardware
125/150 lb	1"	4	1/2-13 x 2	
	1.5"	4	1/2-13 x 2	
	2"	4	5/8-11 x 2.5	
	3"	4	5/8-11 x 3	•
	4"	8	5/8-11 x 3	•
250/300 lb.	1"	4	5/8-11 x 2.25	
	1.5"	4	3/4-10 x 2.5	
	2"	8	5/8x11 x 2.5	
	3"	8	3/4-10 x 3.25	
	4"	8	3/4-10 x 3.75	•

### Potentiometer for CRE, CRIE, CRNE

Potentiometer for setpoint setting and start/stop of the CRE, CRIE, CRNE pump.

Product	Product number
External potentiometer with cabinet for wall mounting	625468

## LiqTec

### Description

LiqTec features:

- Protects the pump against dry-running.
- Protects the pump against too high liquid temperature (+266 °F ± 9 °F (130 °C ± 5 °C)).
- Has a fail-safe design. If the sensor, sensor cable, electronic unit or power supply fails, the pump stops immediately.
- The LiqTec is **not** to be used with the MGFlex motor.

### Mounting the LiqTec sensor

The LiqTec can be fitted to a DIN rail to be incorporated in a control cabinet.

### Electrical connection

Example of electrical connection, see page 129.

### Calibration of sensor and controller

Follow the procedure on the next page.

### Functions



TM03 0111 4004

Fig. 64 LiqTec functions

1. **Connection for dry-running sensor**
2. **Connection for external restarting**
3. **Motor PTC**  
Green light indicates OK or short-circuited terminals.  
Red light indicates too high motor temperature. The alarm relay is activated.

4. **Connection for PTC sensor**  
This input is not used in connection with E-pumps as the variable frequency drive protects the motor against overload.
5. **Sensor indicator light**  
Red light indicates defective sensor or cable. The alarm relay is activated.
6. **Deactivation of the dry-running monitoring function**  
Press the button to deactivate the dry-running monitoring function. Red flashing light. The PTC monitoring function is still active.  
Press [Restart] to reactivate the dry-running monitoring function.
7. **High liquid temperature indicator light**  
Red light indicates too high liquid temperature (+266 °F ± 9 °F (130 °C ± 5 °C)). The alarm relay is activated.
8. **Supply voltage**  
200-240 VAC, 50/60 Hz and 80-130 VAC 50/60 Hz.
9. **Dry-running indicator light**  
Green light indicates OK (liquid in pump).  
Red light indicates dry running (no liquid in pump).  
The alarm relay is activated.
10. **Alarm/Run relay output**  
Potential-free changeover contact.  
Maximum contact load: 250 V, 1 A, AC (inductive load).
11. **Auto/Man**  
Changeover between automatic and manual restarting.  
The default setting is "Man".  
Changeover is carried out by means of a small screwdriver.  
When "Auto" has been selected, the alarm indication will automatically be reset 10 to 20 seconds after detection of liquid.
12. **Restart**  
Press [Restart] to restart the pump. The button has no influence on the PTC monitoring.

### Calibration of sensor and controller

Step	Action	Result
1	Connect the sensor to pos. 1 on the controller and connect the power supply to pos. 8 on the controller. See page 130.	
2	Submerge the sensor into the pumped liquid. The pumped liquid and the air temperature are to be +70 °F. <b>Note:</b> It is important that the pumped liquid is stagnant as the calibration will be misleading if the sensor is cooled by flowing water.	
3	Press the buttons at pos. 6 and pos. 12 on the controller for approximately 20 seconds.	All red indicator lights (except pos. 7) start flashing.
4	When the green indicator lights at pos. 3 and pos. 9 on the controller are constantly on, release the buttons at pos. 6 and pos. 12.	The calibration is completed.

### Further information

Information related to IEC 60730-1:

- Software class A
- Pollution degree 2
- Type 1.

The LiqTec has been cURus-approved according to UL 508.

Maximum pressure: 580 psi (40 bar).

Maximum liquid temperature: (+266 °F ± 9 °F (130 °C ± 5 °C)).

Maximum ambient temperature: +131 °F (+55 °C).

Power consumption: 5 Watt.

Enclosure class: IPX0.

Maximum cable length: 65.6 ft (20 meters).

Standard cable: 16.4 ft (5 meters).

Extension cable: 49.2 ft (15 meters).

**Note:**

The LiqTec is not be connected to the PTC sensor. Assemble a jumper wire between the two terminals at pos. 4 on the controller.

The MLE motor software provides protection against high motor temperature.

The LiqTec is designed for DIN rail mounting in a control cabinet.

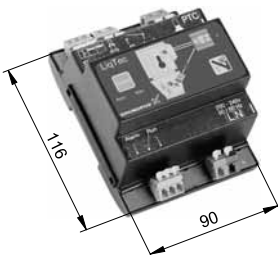
Dry-running protection	Single phase power supply	LiqTec	Sensor 1/2"	Cable 16.4 ft (5 m)	Extension cable 49.2 ft (15 m)	Product number
	200-240 VAC	•	•	•	-	96556429
	80-130 VAC	•	•	•	-	96556430
	-	-	-	-	•	96443676
	-	-	•	•	-	96556427

### Connection of E-pump to LiqTec

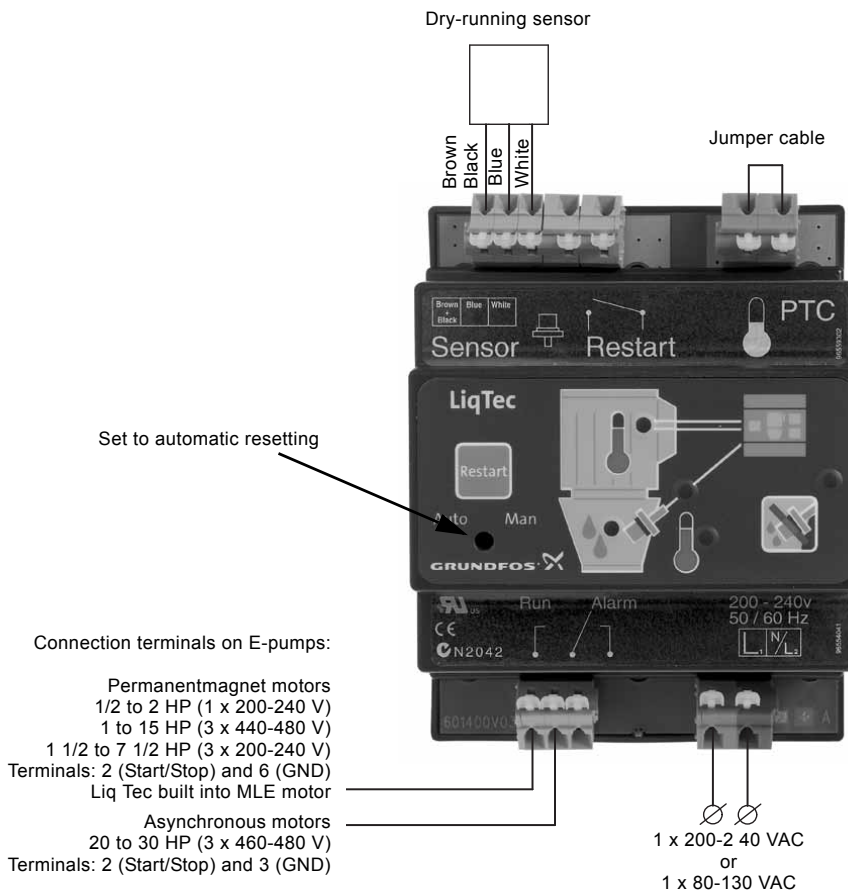

Fig. 65 Connection of E-pump to LiqTec

### Setting the digital input

The digital input must be set to "External fault" via R100.



**Note:** After dry-running fault, the E-pump must be restarted manually.

### Disposal

This product or parts of it must be disposed of in an environmentally sound way:

1. Use the public or private waste collection service.
2. If this is not possible, contact the nearest Grundfos company or service workshop.

TM03 0437 5104

**Pressure sensor**



Accessory	Supplier	Type	Pressure range [psi (bar)]	Product number EPDM	Product number FKM
<b>Pressure sensors</b>			0-87 (0-6)	97748922	97748953
Pressure transmitter with 6 ft screened cable	Grundfos	RPI	0-145 (0-10)	97748923	97748954
Connection: 1/4" - 18 NPT			0-232 (0-16)	97748924	97748955
			0-362 (0-25)	97748925	97748956

TM04 7865 2510

**Technical data**

Pressure sensor				
Product number	97748922	97748923	97748924	97748925
	97748953	97748954	97748955	97748956
Pressure range [psi (bar)]	0-87 (0-6)	0-145 (0-10)	0-232 (0-16)	0-362 (0-25)
Maximum operating pressure [psi (bar)]	870 (60)			
Supply voltage	12.5 - 30 VDC			
Output signal [mA]	4-20			
	60 Ω at 12.5 VDC			
Load impedance	100 Ω at 13.3 V			
	Max 900 Ω at 30 VDC			
Response time	100 ms typical 50 ms			
	1/1000 FS			
Resolution	+32 to +176 °F +/- 2.0 % FS			
Accuracy	-22 to +212 °F +/- 2.5 % FS			
Operation temperature	-22 to +212 °F (-30 to +100 °C)			
Ambient temperature	-13 to +140 °F (-25 to 60 °C)			
Wetted parts material	AISI 316 L			
Housing material	AISI 316 L			
Enclosure	IP 67			
Weight [lb (kg)]	0.3 (14)			
EMC -	EN 61326-1			
Pressure - mechanical connection	Adaptor solution for 1/2" and 1/4" NPT			
Markings				

**Dimensions**

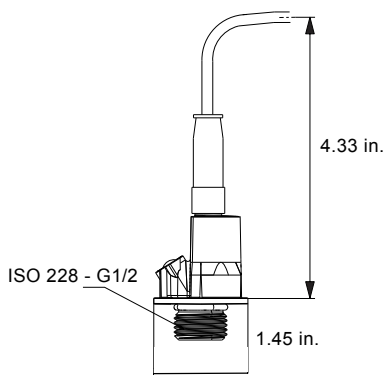

TM04 9237 1612

**Fig. 66** Dimensions RPI transmitter

Pressure sensor



TM05 1533 2911

Accessory	Supplier	Type	Pressure range [psi (bar)]	Product number
<b>Pressure sensors</b> Pressure transmitter with 6 ft screened cable Connection: 1/4" - 18 NPT	Danfoss	MBS3000	0-87 (0-6)	91136169
			0-145 (0-10)	91136170
			0-232 (0-16)	91136171
			0-362 (0-25)	91136172
			0-580 (0-40)	91136173
			0-870 (0-60)	91136174

Technical data

Pressure sensor						
Product number	91136169	91136170	91136171	91136172	91136173	91136174
Pressure range [psi (bar)]	0-87 (0-6)	0-145 (0-10)	0-232 (0-16)	0-362 (0-25)	0-580 (0-40)	0-870 (0-60)
Maximum operating pressure [psi (bar)]	300 (20.1)	300 (20.1)	750 (51.7)	1450 (100)	2900 (200)	2900 (200)
Supply voltage	9-32 VDC					
Output signal [mA]	4-20					
Insulation resistance	> 100 MΩ at 100 V					
Accuracy, typical +/- FS [%]	0.5 %					
Response time, maximum [ms]	4 ms					
Medium temperature range [°F (°C)]	-40 °F to +185 °F (-40 °C to +85 °C)					
Ambient temperature range [°F (°C)]	-40 °F to +185 °F (-40 °C to +85 °C)					
Wetted parts, material	AISI 316L					
Housing material	AISI 316L					
Enclosure rating	IP65					
Weight [lb (kg)]	0.3 (0.14)					
EMC - Emission	EN 61000-6-3					
EMC Immunity	EN 61000-6-2					
Pressure connection	NPT 1/4-18					
CE-marked	EMC protected in accordance with EU EMC Directive					

Dimensions

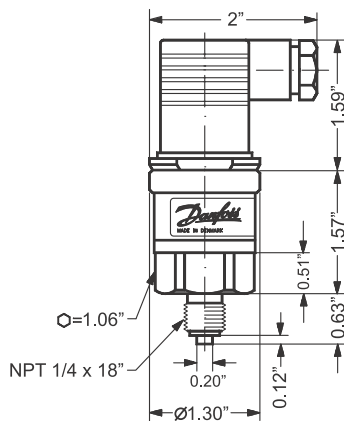

TM05 1532 2911

Fig. 67 Dimensional sketch

## Grundfos differential-pressure sensor, DPI



Grundfos differential-pressure sensor, DPI	Pressure range [psi (bar)]	Product number
<ul style="list-style-type: none"> <li>• 1 sensor incl. 0.9 m screened cable (7/16" connections)</li> <li>• 1 original DPI bracket (for wall mounting)</li> <li>• 1 Grundfos bracket (for mounting on motor)</li> <li>• 2 M4 screws for mounting of sensor on bracket</li> <li>• 1 M6 screw (self-cutting) for mounting on 3 HP and smaller</li> <li>• 1 M8 screw (self-cutting) for mounting on 5-10 HP</li> <li>• 1 M10 screw (self-cutting) for mounting on 15-25 HP</li> <li>• 1 M12 screw (self-cutting) for mounting on 30 HP</li> <li>• 3 capillary tubes (short/long)</li> <li>• 2 fittings (1/4" - 7/16")</li> <li>• 5 cable clips (black)</li> <li>• Installation and operating instructions</li> </ul>	0 - 8.7 (0 - 0.6)	96611522
	0 - 14.5 (0 - 1.0)	96611523
	0-23 (0 - 1.6)	96611524
	0-36 (0 - 2.5)	96611525
	0-58 (0 - 4.0)	96611526
	0-87 (0 - 6.0)	96611527
	0-145 (0-10)	96611550

Select the differential-pressure sensor so that the maximum pressure of the sensor is higher than the maximum differential pressure of the pump.

The sensor housing and parts in contact with the liquid are made of Inox DIN 1.4305 (3) with composite PA top (2). The connections (4) are DIN 1.4305, 7/16" UNF connection and gaskets are FKM.

A black and screened cable (1) goes through a screwed connection PG with M 12 x 1.5 connection.

The sensor is supplied with angular bracket for mounting on motor or bracket for wall mounting.

A specially coated silicon chip is used for greater accuracy.

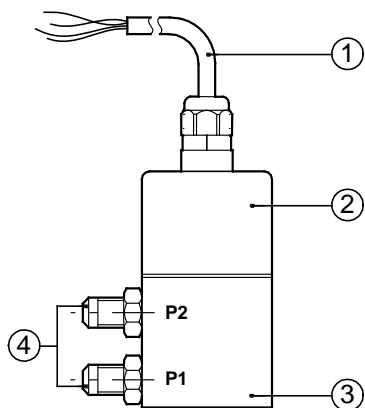

TM03 2057 3505

Fig. 68 DPI sensor

**Technical data**

Grundfos differential-pressure sensor, DPI							
Product number	96611522	96611523	96611524	96611525	96611526	96611527	96611550
Pressure ranges, differential pressure [psi (bar)]	0 - 8.7 (0 - 0.6)	0 - 14.5 (0 - 1.0)	0-23 (0 - 1.6)	0-36 (0 - 2.5)	0-58 (0 - 4.0)	0-87 (0 - 6.0)	0-145 (0-10)
Supply voltage	12-30 VDC						
Output signal	4-20 mA						
Load [Ω]	24 V: max. 500 [Ω], 16 V: max. 200 [Ω], 12 V: max. 100 [Ω]						
Maximum system pressure, P1 and P2 simultaneously [psi (bar)]	232 (16)						
Rupture pressure [bar]	1.5 x system pressure						
Measuring accuracy	2.5 % BFSL						
Response time	< 0.5 seconds						
Liquid temperature range	+14 °F to +158 °F (-10 °C to +70 °C)						
Storage temperature range	-40 °F to +176 °F (-40 °C to +80 °C)						
Electrical connection	26 GA, 3 ft cable - M12 x 1.5 in sensor top						
Short circuit-proof	Yes						
Protected against reverse polarity	Yes						
Over supply voltage	Yes						
Materials in contact with liquid	DIN 1.4305 FKM and PPS						
Enclosure class	IP55						
Weight [lb]	1.2						
EMC (electromagnetic compatibility)	According to EN 60335-1						
Emission/immunity	According to EN 61800-3						
Connections	7/16"-UNF						
Sealing material	FKM						

**Dimensions**

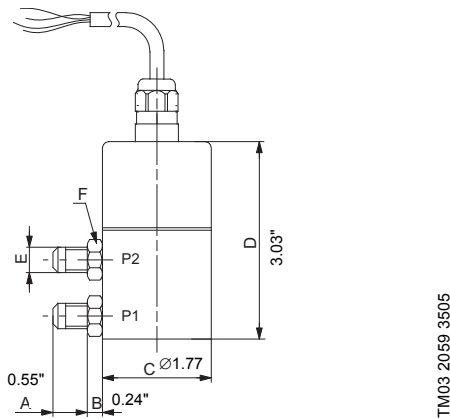

**Fig. 69** Dimensional sketch

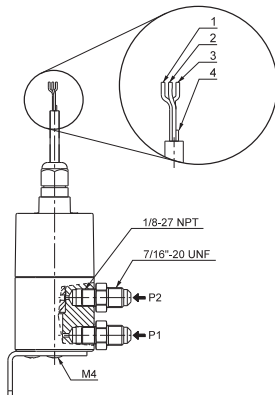

**Fig. 70** Wiring

1	12-30 V supply voltage	Brown
2	GND (earth conductor)	Yellow
3	Signal conductor	Green
4	Test conductor (can be cut off during mounting). This conductor must not be connected to the power supply.	White

### Grundfos differential-pressure sensor, DPI g.2 version



TM04 7866 2410

Grundfos differential-pressure sensor, DPI g.2 version

- 1 sensor
- 1 capillary tube short version
- 1 fitting for capillary tube
- 6 ft (1.8 m) cable
- 1 installation and operation instructions

**Pressure range  
[psi (bar)]**

**Product number**

0 - 8.7 (0 - 0.6)	97747194
0 - 14.5 (0 - 1.0)	97747195
0-23 (0 - 1.6)	97747196
0-36 (0 - 2.5)	97747197
0-58 (0 - 4.0)	97747198
0-87 (0 - 6.0)	97747199
0-145 (0-10)	97747200

Select the differential-pressure sensor so that the maximum pressure of the sensor is higher than the maximum differential pressure of the pump.

All materials used for DPI 2 are 316 L.

Fitting connection for capillary tube is 7/16" UNF.

Cable with M12 x 4 connector.

Sensor is supplied with fitting for capillary tubing.

Measuring technology is based on Coated Silicon Chip.

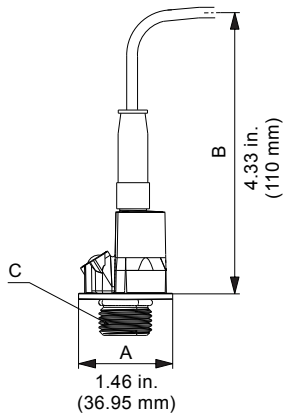

TM04 9237 3710

**Fig. 71** DPI sensor g.2 version

**Technical data**

**Grundfos differential-pressure sensor, DPI g.2 version**

Product number	97747194	97747195	97747196	97747197	97747198	97747199	97747200
Pressure ranges, differential pressure [psi (bar)]	0 - 8.7 (0 - 0.6)	0 - 14.5 (0 - 1.0)	0-23 (0 - 1.6)	0-36 (0 - 2.5)	0-58 (0 - 4.0)	0-87 (0 - 6.0)	0-145 (0-10)
Supply voltage	12-30 VDC						
Output signal	4-20 mA						
Load [ $\Omega$ ]	30 V DC: max. 900 ohms [ $\Omega$ ], 1.3 V: max. 100 [ $\Omega$ ], 12.5 V: max. 60 [ $\Omega$ ]						
Maximum system pressure, P1 and P2 simultaneously [psi (bar)]	870 (60)						
Rupture pressure [bar]	1.5 x system pressure						
Measuring accuracy	2.0 % FS						
Response time	< 100 ms (typical 50 ms)						
Liquid temperature range	-22 to +212 °F (-30 to +100 °C)						
Storage temperature range	-67 to +158 °F (-55 to +70 °C)						
Electrical connection	27 ga, 6 ft (1.8) cable M 12 x 4						
Short circuit-proof	Yes						
Protected against reverse polarity	Yes						
Over supply voltage	Yes						
Materials in contact with liquid	AISI 316 L						
Enclosure class	IP67						
Weight [lb]	1.2						
EMC (electromagnetic compatibility)	According to EN 61326-1						
Connections	7/16"-UNF						
Sealing material	EPDM						

**Dimensions**

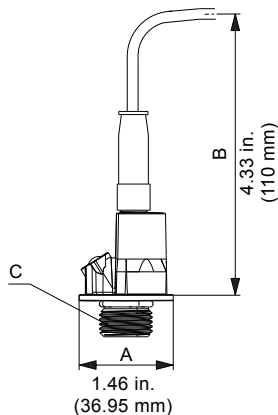

**Fig. 72** DPI sensor g.2 version

**Electrical connections**

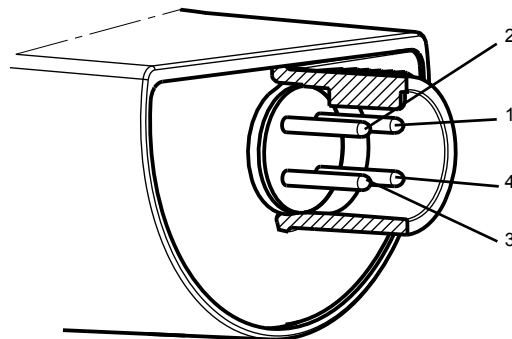

**Fig. 73** Electrical connections

PIN	1	2	3	4
Wire color	Brown	Grey	Blue	Black
Output 4-20 mA	+	Not used	-	Not used
Output 2 x 0-10 V	+	Pressure signal	-*	Temperature signal

\* Common ground for both pressure and temperature signal.  
 \* Power supply (screened cable): SELV or PELV.

## Flow transmitters

- Flow tube in AISI 316 mounted with transmitter
- Transmitter AISI 316 L
- 4-20 mA output signal
- 2 x flanges
- 15 ft cable free ends
- quick guide.

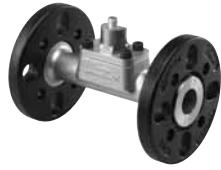

Type	Flow range [gpm]	Connection	O-ring		Flange material		Product number
			EPDM	FKM	Cast iron	Stainless	
VFI 0.3-6	1.3 - 26	3/4"	•		•		97686127
	1.3 - 2.6	3/4"	•			•	97688293
VFI 0.6-12	2.6 - 53	1"	•		•		97686129
	2.6 - 53	1"	•			•	97688295
VFI 1.3-25	5.7 - 110	1 1/4"	•		•		97686141
	5.7 - 110	1 1/4"	•			•	97688297
VFI 2-40	8.8 - 176	1 3/4"	•		•		97686143
	8.8 - 176	1 3/4"	•			•	97688299
VFI 3.2-64	14-282	2"	•		•		97686145
	14-282	2"	•			•	97688301
VFI 5.2-104	23-458	2 1/2"	•		•		96788476
VFI 8-160	35-704	3"	•		•		97788478
VFI 8-160	53-1060	4"	•		•		97788492

TM04 7362 2210

For more information about the VFI sensor, see the Grundfos Direct Sensors data booklet, publication number 97790189, at [www.grundfos.com](http://www.grundfos.com) (Grundfos Product Center).

## Gauges for CRE, CRIE, CRNE

Accessory	Measuring range	Product number
Liquid filled pressure gauge • AISI 304/Copper	30" Hg - 30 psi	91123566
	0-60 psi	00ID8562
	0-100 psi	00ID8563
	0-160 psi	00ID8564
	0-200 psi	00ID8565
	0-300 psi	00ID8566
	0-400 psi	00ID8567
Liquid filled pressure gauge • AISI 316	0-600 psi	00ID8568
	30" Hg - 30 psi	91130835
	0-60 psi	00ID8569
	0-100 psi	00ID8570
	0-160 psi	00ID8571
	0-200 psi	00ID8572
	0-300 psi	00ID8573
	0-400 psi	00ID8574
	0-600 psi	00ID8575
	0-200 psi	00ID8576

## Remote controls

### Grundfos GO Remote

Grundfos GO Remote is used for wireless infrared or radio communication with the pumps.

Various Grundfos GO Remote variants are available. The variants are described in the following.

#### MI 202 and MI 204

The MI 202 and MI 204 are add-on modules with built-in infrared and radio communication. The MI202 can be used in conjunction with an Apple iPhone or iPod with 30-pin connector and iOS. 5.0 or later, e.g. fourth generation iPhone or iPod.

The MI 204 can be used in conjunction with an Apple iPhone or iPod with Lightning connector, e.g. fifth generation iPhone or iPod.

(The MI 204 is also available together with an Apple iPod touch and a cover.)



Fig. 74 MI 202 and MI 204

Supplied with the product:

- Grundfos MI 202 or MI 204
- sleeve
- quick guide
- charger cable.

TM05 3887 1612 - TM05 7704 1513

#### MI 301

The MI 301 is a module with built-in infrared and radio communication. The MI 301 can be used in conjunction with Android or iOS-based smart devices with a Bluetooth connection. The MI 301 has rechargeable Li-ion battery and must be charged separately.



TM05 3890 1712

Fig. 75 MI 301

Supplied with the product:

- Grundfos MI 301
- sleeve
- battery charger
- quick guide.

#### Product numbers

Grundfos GO Remote variant	Product number
Grundfos MI 202	98046376
Grundfos MI 204	98424092
Grundfos MI 204 including iPod touch	98612711
Grundfos MI 301	98046408

## CIU communication interface units



GrA 6118

**Fig. 76** Grundfos CIU communication interface unit

The CIU units enable communication of operating data, such as measured values and setpoints, between CRE, CRIE, CRNE pumps and a building management system. The CIU unit incorporates a 24-240 VAC/VDC power supply module and a CIM module. It can either be mounted on a DIN rail or on a wall.

We offer the following CIU units:

### CIU 100

For communication via LonWorks.

### CIU 150

For communication via PROFIBUS DP.

### CIU 200

For communication via Modbus RTU.

### CIU 250

For wireless communication via GSM/GPRS.

### CIU 271

For communication via Grundfos Remote Management (GRM).

### CIU 300

For communication via BACnet MS/TP.

Description	Fieldbus protocol	Product number
CIU 100	LonWorks	96753735
CIU 150	PROFIBUS DP	96753081
CIU 200	Modbus RTU	96753082
CIU 250*	GSM/GPRS	96787106
CIU 271*	GRM	96898819
CIU 300	BACnet MS/TP	Contact Grundfos

\* Antenna not included. See below.

### Antennas for CIU 250 and 270

Description	Product number
Antenna for roof	97631956
Antenna for desk	97631957

For further information about data communication via CIU units and fieldbus protocols, see the CIU documentation available at [www.grundfos.com](http://www.grundfos.com) (Grundfos Product Center).

## CIM communication interface modules



GrA 6121

**Fig. 77** Grundfos CIM communication interface module

The CIM modules enable communication of operating data, such as measured values and setpoints, between CRE, CRIE or CRNE pumps of 11-22 kW and a building management system. The CIM modules are add-on communication modules which are fitted in the terminal box of CRE, CRIE, CRNE pumps of 11-22 kW.

**Note:** CIM modules must be fitted by authorised persons.

We offer the following CIM modules:

### CIM 100

For communication via LonWorks.

### CIM 150

For communication via PROFIBUS DP.

### CIM 200

For communication via Modbus RTU.

### CIM 250

For wireless communication via GSM/GPRS.

### CIM 271

For communication via Grundfos Remote Management (GRM).

### CIM 300

For communication via BACnet MS/TP.

Description	Fieldbus protocol	Product number
CIM 100	LonWorks	96824797
CIM 150	PROFIBUS DP	96824793
CIM 200	Modbus RTU	96824796
CIM 250*	GSM/GPRS	96824795
CIM 271*	GRM	96898815
CIM 300	BACnet MS/TP	Contact Grundfos

\* Antenna not included. See below.

### Antennas for CIM 250 and 270

Description	Product number
Antenna for roof	97631956
Antenna for desk	97631957

For further information about data communication via CIM modules and fieldbus protocols, see the CIM documentation available at [www.grundfos.com](http://www.grundfos.com) (Grundfos Product Center).

## MP 204 motor protector



Fig. 78 MP 204

TM03 1471 2205

The MP 204 is an electronic motor protector and data collecting unit. Apart from protecting the motor, it can also send information to a control unit via GENIbus, like for instance:

- trip
- warning
- energy consumption
- input power
- motor temperature.

The MP 204 protects the motor primarily by measuring the motor current by means of a true RMS measurement.

The pump is protected secondarily by measuring the temperature with a Tempcon sensor, a Pt100/Pt1000 sensor and a PTC sensor/thermal switch.

The MP 204 is designed for single- and three-phase motors.

**Note:** The MP 204 must not be used together with frequency converters.

### Features

- Phase-sequence monitoring
- indication of current or temperature
- input for PTC sensor/thermal switch
- indication of temperature in °C or °F
- 4-digit, 7-segment display
- setting and status reading with the Grundfos R100 remote control
- setting and status reading via the Grundfos GENIbus fieldbus.

### Tripping conditions

- Overload
- underload (dry running)
- temperature
- missing phase
- phase sequence
- overvoltage
- undervoltage
- power factor ( $\cos \varphi$ )
- current unbalance.

### Warnings

- Overload
- underload
- temperature
- overvoltage
- undervoltage
- power factor ( $\cos \varphi$ )
- run capacitor (single-phase operation)
- starting capacitor (single-phase operation)
- loss of communication in network
- harmonic distortion.

### Learning function

- Phase sequence (three-phase operation)
- run capacitor (single-phase operation)
- starting capacitor (single-phase operation)
- identification and measurement of Pt100/Pt1000 sensor circuit.

### Product number

Description	Product number
MP 204 motor protection	96079927

## 16. Variants

### Lists of variants on request

Although the Grundfos CR(E)-H, CRN(E)-H product range offers a number of pumps for different applications, customers require specific pump solutions to satisfy their needs.

Below please find the range of options available for customizing the CR(E)-H, CRN(E)-H pumps to meet the customers' demands. Contact Grundfos for further information or for requests other than the ones mentioned below.

### Motors

Variant	Description
<b>Explosion-proof motors</b>	For operation in hazardous atmospheres, explosion-proof or dust-ignition-proof motors may be required.
<b>Motors with anti-condensation heating unit</b>	For operation in humid environments motors with built-in anti-condensation heating may be required.
<b>Different motor brand</b>	If technically possible, Grundfos can fit the pump with a motor of a brand other than the standard. This will normally increase the time of delivery. Alternatively, the pump can be supplied without a motor (motor thrust rating must be checked).
<b>Oversized motor</b>	Ambient temperatures above 104 °F or installation at altitudes of more than 3280 ft above sea level require the use of an oversized motor (i.e. derating).
<b>4-pole motors</b>	Grundfos offers standard motors fitted with 4-poles.

### Connections and other variants

Variant	Description
<b>Pipe connections</b>	In addition to the wide range of standard flange connections, DIN standard flanges are available. Customized flanges are available according to specifications.
<b>Electropolished pumps</b>	To substantially reduce the risk of corrosion of the materials. For use in the pharmaceutical/food industry.

### Shaft seals

Variant	Description
<b>Shaft seal with FFKM O-ring material</b>	We recommend shaft seals with FFKM or FXM o-ring material for applications where the pumped liquid may damage the standard O-ring material.
<b>Seal with flush, quench seal</b>	Recommended for applications involving crystallizing, hardening or sticky liquids.
<b>Cool-Top® shaft seal system</b>	Recommended for applications involving extremely high temperatures. No conventional mechanical shaft seal can withstand liquid temperatures of up to 356 °F for any length of time. For that type of application, we recommend Grundfos' unique air-cooled shaft seal system. In order to ensure a low liquid temperature around the standard shaft seal, the pump is fitted with a special air-cooled shaft seal chamber. No separate cooling is required.
<b>Double shaft seal with pressure chamber</b>	Recommended for applications involving poisonous or explosive liquids. Protects the surrounding environment and the people working in the vicinity of the pump. Consists of two seals mounted in a "back-to-back" arrangement inside a separate pressure seal chamber. As the pressure in the chamber is higher than the pump pressure, leakage is prevented. A dosing pump or a special pressure-intensifier generates the seal chamber pressure.
<b>CRN MAGdrive</b>	Magnetically driven pumps for industrial applications. Key applications are industrial processes involving the handling of aggressive, environmental, dangerous or volatile liquids, e.g. organic compounds, solvents, etc.

### Pumps

Variant	Description
<b>Low-temperature pump to -4 °F</b>	Exposed to temperatures down to -40 °F, coolant pumps may require neck-rings with a different diameter in order to prevent impeller drag.
<b>Low-NPSH pump (improved suction)</b>	Recommended for boiler-feed applications where cavitation may occur due to poor inlet conditions.
<b>Belt-driven pumps</b>	Belt-driven pumps designed to operate in places with limited space or where no electrical power is available.
<b>Pumps for pharmaceutical and biotechnological applications</b>	CRN(E) pumps designed for applications requiring the sterilization and CIP capability of pipes, valves and pumps. (CIP = Cleaning-In-Place).

## 17. Grundfos Product Center

Online search and sizing tool to help you make the right choice.

<http://product-selection.grundfos.com>



"SIZING" enables you to size a pump based on entered data and selection choices.

"REPLACEMENT" enables you to find a replacement product. Search results will include information on

- the lowest purchase price
- the lowest energy consumption
- the lowest total life cycle cost.

www.grundfos.us Login

**GRUNDFOS** | PRODUCT CENTER Product range: USA | 60 Hz | Language: English (USA)  
Change settings

HOME FIND PRODUCT COMPARE YOUR PROJECTS SAVED ITEMS HELP 1.5.29

### FIND PRODUCTS AND SOLUTIONS

Input product number or a whole or partial product name SEARCH

**SIZING**  
Enter pump sizing

**CATALOG**  
Product and services

**REPLACEMENT**  
Replace an old pump with a new

**LIQUIDS**  
Find liquid pump

QUICK SIZING

**Enter duty point:**

Flow (Q)\*  US gpm

Head (H)\*  ft

**Select what to size by:**

Size by application

Size by pump design

Size by pump family

**START SIZING**

ADVANCED SIZING:  Advanced sizing by application  Guided selection

"CATALOG" gives you access to the Grundfos product catalog.

"LIQUIDS" enables you to find pumps designed for aggressive, flammable or other special liquids.

### All the information you need in one place

Performance curves, technical specifications, pictures, dimensional drawings, motor curves, wiring diagrams, spare parts, service kits, 3D drawings, documents, system parts. The Product Center displays any recent and saved items - including complete projects - right on the main page.

### Downloads

On the product pages, you can download Installation and Operating Instructions, Data Booklets, Service Instructions, etc. in PDF format.

## Grundfos GO

### Mobile solution for professionals on the GO!

Grundfos GO is the mobile tool box for professional users on the go. It is the most comprehensive platform for mobile pump control and pump selection including sizing, replacement and documentation. It offers intuitive, handheld assistance and access to Grundfos online tools, and it saves valuable time for reporting and data collection.

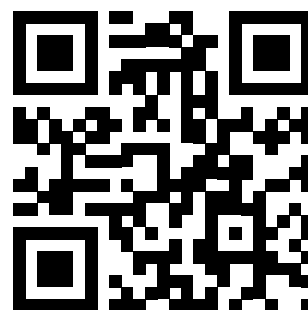
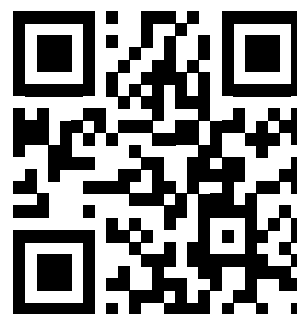

## 18. Submittal data

### Client information

Project title:	Client name:
Reference number:	Client number:
Client contact:	Client phone number: (     )

### Location information

For:	Unit:		
Site:	Service:		
Address:	City:	State:	Zip code:

### Application information

Operating conditions				Pumped fluid			
	Max.	Norm.	Min.	Fluid type:	Rated	Max.	Norm.
Capacity (gpm)				Fluid temperature (°F)			
Inlet pressure (psig)				at designated temperature			
Outlet pressure (psig)				Specific gravity			
Differential head (ft)				Vapor pressure (psia)			
Hydraulic power at designated capacity				Viscosity (cp)			
NPSH available (ft)				Fluid ph:		Chlorides (ppm):	
				Hazardous:		Corrosion/erosion caused by:	
<b>Service</b>				Flammable:			
Continuous				Other:			
Intermittent (starts/day):							

### Pump information

Model information from Type Key and Codes:	
Quantity required:	
Minimum required flow:	NPSH required at duty point:
<b>Product Guide additional information pages</b>	
Materials page number:	Performance curve page number:
Technical data page number:	Motor data page number:

### Motor information

Hp:	Phase:	Voltage:	Enclosure:
-----	--------	----------	------------

### Custom-built pump information (optional):

### Additional information

# 19. Quotation text

## CR-H, CRN-H, CRE-H, CRNE-H

Horizontal, non-self-priming, multistage, end-suction, centrifugal pump for installation in pipe systems and mounting on a foundation.

The pump has the following characteristics:

- impellers and intermediate chambers are made of AISI \_\_\_\_\_ stainless steel
- pump head and volute are made of \_\_\_\_\_
- power transmission is via cast iron split coupling.
- pipe connection is via \_\_\_\_\_

The motor is a \_\_\_\_\_ -phase AC motor.

### Technical

Rated flow: \_\_\_\_\_ gpm  
 Rated head: \_\_\_\_\_ ft  
 Minimum liquid temperature: \_\_\_\_\_ °F  
 Maximum liquid temperature: \_\_\_\_\_ °F  
 Type of shaft seal: \_\_\_\_\_

### Materials

Material, pump housing: \_\_\_\_\_  
 Material, shaft: AISI \_\_\_\_\_ stainless steel  
 Material, impeller: AISI \_\_\_\_\_ stainless steel  
 Material, sleeve: AISI \_\_\_\_\_ stainless steel  
 Material, seal metal: AISI \_\_\_\_\_ stainless steel  
 - seal face: \_\_\_\_\_  
 - seal face: \_\_\_\_\_  
 - seal elastomer: \_\_\_\_\_

### Installation

Maximum ambient temperature: \_\_\_\_\_ °F  
 Maximum pressure at stated temp.: \_\_\_\_\_ psi / °F  
 Standard, pipe connection: \_\_\_\_\_  
 Size, pipe connection: \_\_\_\_\_  
 Rated pressure, pipe connection: \_\_\_\_\_ psi  
 Frame size for motor: \_\_\_\_\_ NEMA

### Electrical data

Motor type: \_\_\_\_\_  
 Rated power (P2): \_\_\_\_\_ Hp  
 Frequency: \_\_\_\_\_ Hz  
 Rated voltage: \_\_\_\_\_ V  
 Rated current: \_\_\_\_\_ A  
 Service factor: \_\_\_\_\_  
 Starting current: \_\_\_\_\_ A  
 Rated speed: \_\_\_\_\_ rpm  
 Full load motor efficiency: \_\_\_\_\_ %  
 Insulation class: \_\_\_\_\_

### Additional

Gross weight: \_\_\_\_\_ lbs.  
 Shipping volume: \_\_\_\_\_ ft<sup>3</sup>  
 Model: \_\_\_\_\_



<b>98665987</b> 0518
----------------------

ECM: 1233699
--------------

**Grundfos Kansas City**

17100 West 118th Terrace  
Olathe, Kansas 66061  
Phone: 913-227-3400  
Fax: 913-227-3500  
[www.grundfos.us](http://www.grundfos.us)

**Grundfos Canada**

2941 Brighton Road  
Oakville, Ontario L6H 6C9 Canada  
Phone: +1-905-829-9533  
Fax: +1-905-829-9512  
[www.grundfos.ca](http://www.grundfos.ca)

**Grundfos México**

Boulevard TLC No. 15  
Parque Industrial Stiva Aeropuerto  
C.P. 66600 Apodaca, N.L. Mexico  
Phone: 011-52-81-8144 4000  
Fax: 011-52-81-8144 4010  
[www.grundfos.mx](http://www.grundfos.mx)