



# TYPE "B" SINGLE STAGE CENTRIFUGAL PUMP Electric Motor Drive

Section	CC
Page	420.1
Date	January 1, 2004
Supersedes 6/1/95	

## CAST IRON IMPELLER

## B8GPBM

### Flanged Case

### Packing Construction

**TABLE I**

B/M No.	HP	PH	RPM	"U" Dim.	Imp. Dia.	Imp. No.
<b>B53863</b>	15	3	1200	1-1/4"	9.38"x10.62"	M07772
<b>B53864</b>	20	3	1200	1-1/4"	10.62"x11.12"	M07773
<b>B51798</b>	25	3	1200	1-1/4"	11.50"	M07771
<b>B51799</b>	30	3	1200	1-1/4"	12.12"	M03800

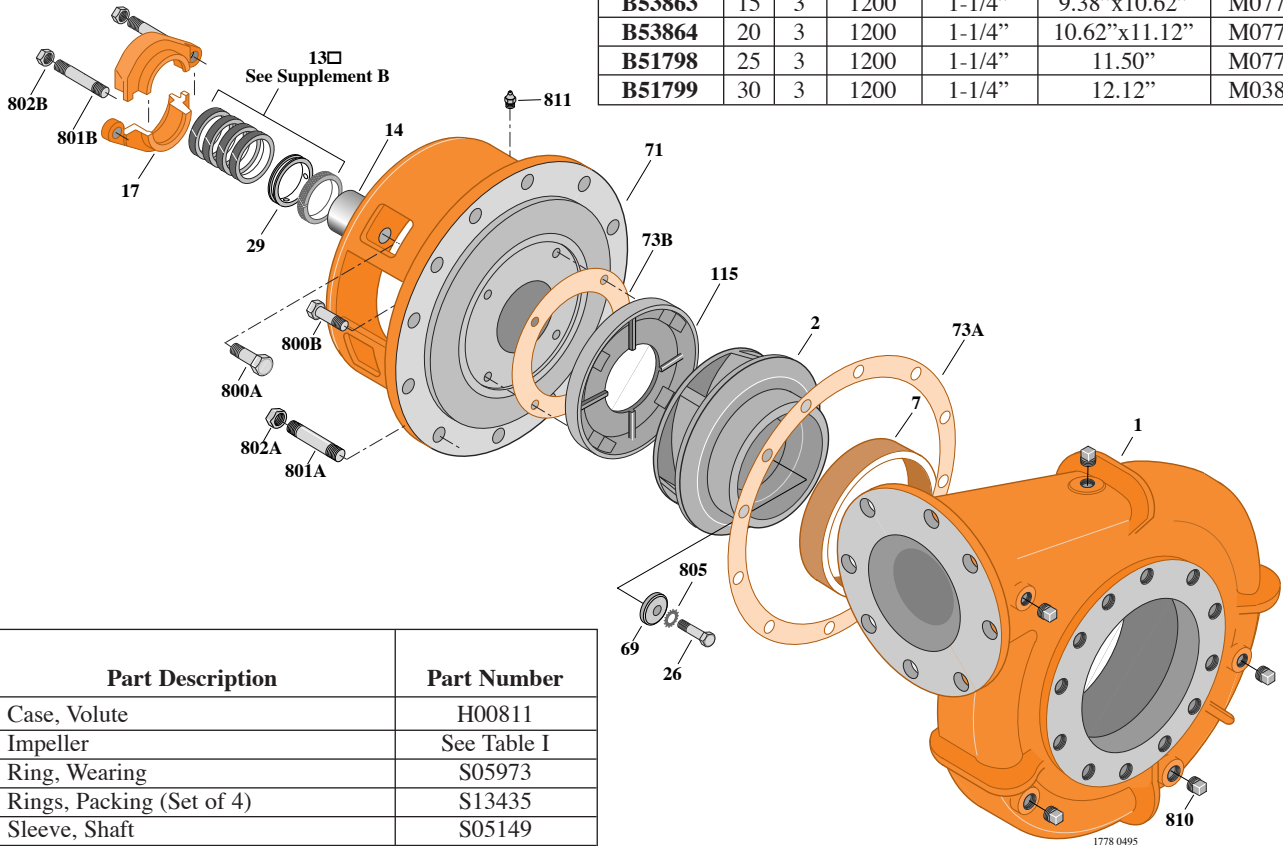

Item No.	Part Description	Part Number
1	Case, Volute	H00811
2	Impeller	See Table I
7	Ring, Wearing	S05973
13	Rings, Packing (Set of 4)	S13435
14	Sleeve, Shaft	S05149
17	Gland, Packing	B82470
26	Screw, Impeller 1/2 - 13 x 3"	S23631
29	Ring, Lantern	S19200
32	Key, 1/4 x 2-1/4" (See Note)	S23677
69	Washer, Impeller	S06319
71	Bracket	See Table II
73A	Gasket, Volute Case	S06271
73B	Gasket, Balance Ring	S09943
115	Ring, Balance	S14065
800A	Capscrew, 5/8 - 11 x 1-1/2" (4 Req.)	S26999
800B	Capscrew, 3/8 - 16 x 1-1/2" (4 Req.)	S26830
801A	Stud, 5/8 - 11 x 2-1/4" (12 Req.)	S24061
801B	Stud, 3/8 - 16 x 2-1/2" (2 Req.)	S04438
802A	Nut, Hex 5/8 - 11 (12 Req.)	S23109
802B	Nut, Hex 3/8 - 16 (2 Req.)	S23343
805	Washer, Lock	S23038
810	Plug, Pipe 1/2 NPT (5 Req.)	S23717
811	Fitting, Grease	S23700
812	Elbow, Street	S25421

**TABLE II**

HP	PH	Bracket No.	"AK" Fit	"U" Dim.	Motor Frame
15	3	H01601	12-1/2"	1-1/4"	284JP
20	3	H01601	12-1/2"	1-1/4"	286JP
25	3	H01601	12-1/2"	1-1/4"	324JP
30	3	H01601	12-1/2"	1-1/4"	326JP

**NOTE:** For an explanation of the tabulated material found on this page and for impeller key location, refer to *Supplement A* located at the beginning of this section.



# TYPE "B" SINGLE STAGE CENTRIFUGAL PUMP Electric Motor Drive

Section	CC
Page	420.2
Date	January 1, 2004
Supersedes 6/1/95	

## CAST IRON IMPELLER

## B8GPBM

### Flanged Case

### Packing Construction

TABLE I

B/M No.	HP	PH	RPM	"U" Dim.	Imp. Dia.	Imp. No.
B51766	40	3	1800	1-1/4"	8.62"x10.18"	M07769
B51767	50	3	1800	1-1/4"	9.44"x10.62"	M07770

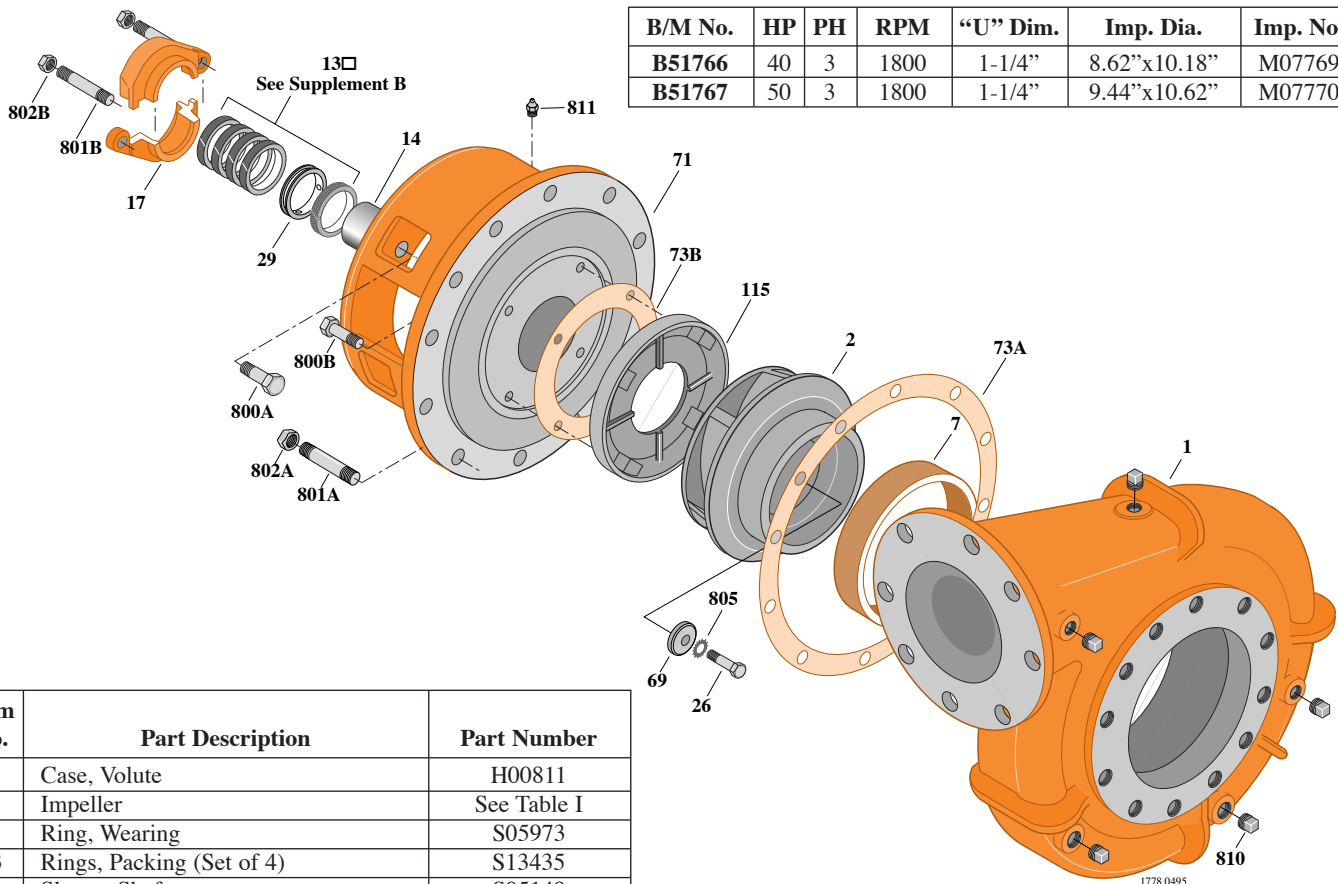

Item No.	Part Description	Part Number
1	Case, Volute	H00811
2	Impeller	See Table I
7	Ring, Wearing	S05973
13	Rings, Packing (Set of 4)	S13435
14	Sleeve, Shaft	S05149
17	Gland, Packing	B82470
26	Screw, Impeller 1/2 - 13 x 3"	S23631
29	Ring, Lantern	S19200
32	Key, 1/4 x 2-1/4" (See Note)	S23677
69	Washer, Impeller	S06319
71	Bracket	See Table II
73A	Gasket, Volute Case	S06271
73B	Gasket, Balance Ring	S09943
115	Ring, Balance	S14065
800A	Capscrew, 5/8 - 11 x 1-1/2" (4 Req.)	S26999
800B	Capscrew, 3/8 - 16 x 1-1/2" (4 Req.)	S26830
801A	Stud, 5/8 - 11 x 2-1/4" (12 Req.)	S24061
801B	Stud, 3/8 - 16 x 2-1/2" (2 Req.)	S04438
802A	Nut, Hex 5/8 - 11 (12 Req.)	S23109
802B	Nut, Hex 3/8 - 16 (2 Req.)	S23343
805	Washer, Lock	S23038
810	Plug, Pipe 1/2 NPT (5 Req.)	S23717
811	Fitting, Grease	S23700
812	Elbow, Street	S25421

TABLE II

HP	PH	Bracket No.	"AK" Fit	"U" Dim.	Motor Frame
40	3	H01601	12-1/2"	1-1/4"	324JP
50	3	H01601	12-1/2"	1-1/4"	326JP

**NOTE:** For an explanation of the tabulated material found on this page and for impeller key location, refer to *Supplement A* located at the beginning of this section.



# TYPE "B" SINGLE STAGE CENTRIFUGAL PUMP Electric Motor Drive

Section	CC
Page	420.3
Date	January 1, 2004
Supersedes 6/1/95	

## CAST IRON IMPELLER

## B8GPBM

### Flanged Case

### Packing Construction

**TABLE I**

B/M No.	HP	PH	RPM	"U" Dim.	Imp. Dia.	Imp. No.
B55999	60	3	1800	1-5/8"	10.00"x10.75"	M07774
B56000	75	3	1800	1-5/8"	10.81"x11.38"	M07775

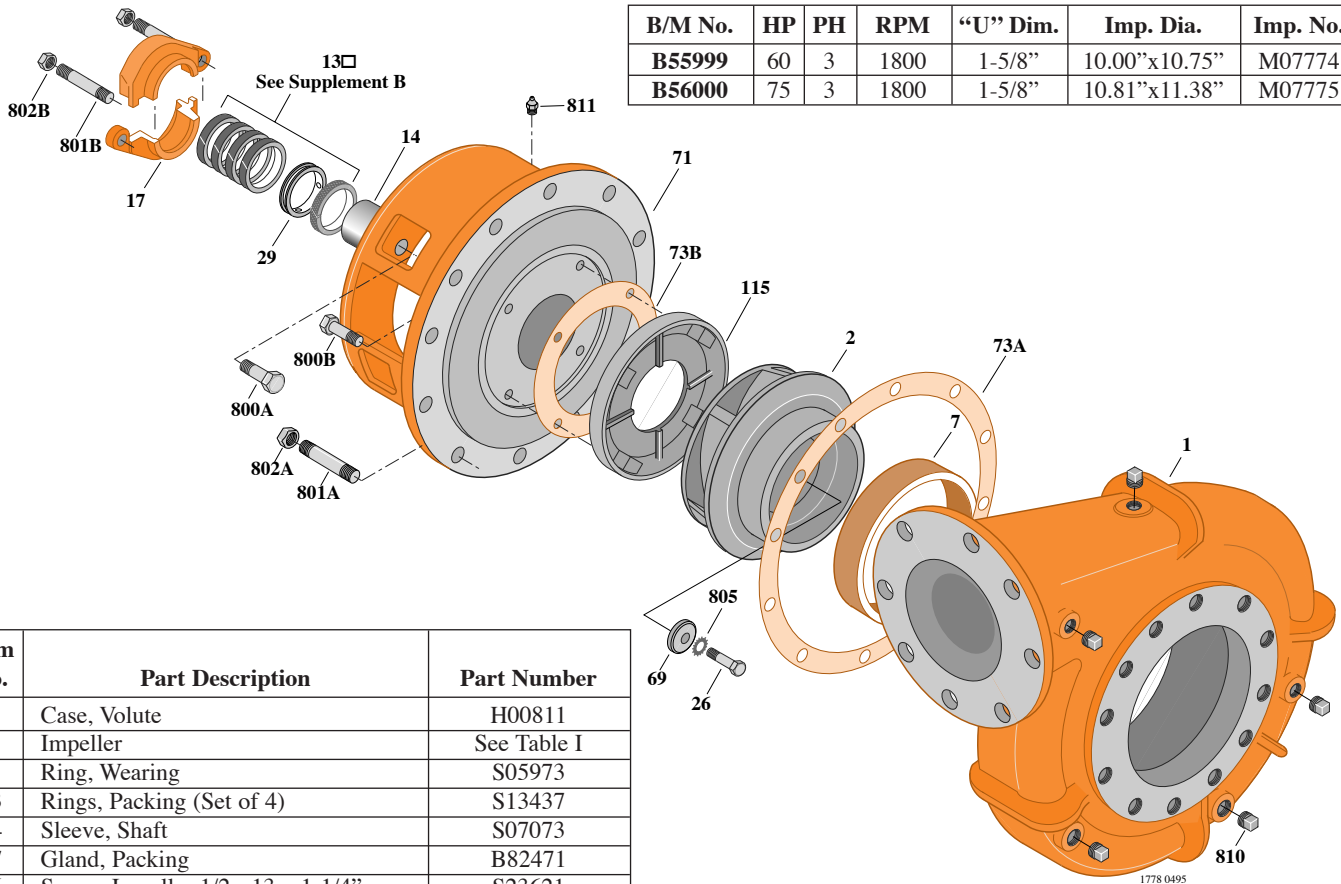

Item No.	Part Description	Part Number
1	Case, Volute	H00811
2	Impeller	See Table I
7	Ring, Wearing	S05973
13	Rings, Packing (Set of 4)	S13437
14	Sleeve, Shaft	S07073
17	Gland, Packing	B82471
26	Screw, Impeller 1/2 - 13 x 1-1/4"	S23621
29	Ring, Lantern	S19198
32	Key, 3/8 x 2-1/4" (See Note)	S23940
69	Washer, Impeller	S34492
71	Bracket	See Table II
73A	Gasket, Volute Case	S06271
73B	Gasket, Balance Ring	S09943
115	Ring, Balance	S14065
800A	Capscrew, 5/8 - 11 x 1-3/4" (4 Req.)	S27001
800B	Capscrew, 3/8 - 16 x 1-1/2" (4 Req.)	S26830
801A	Stud, 5/8 - 11 x 2-1/4" (12 Req.)	S24061
801B	Stud, 3/8 - 16 x 2-1/2" (2 Req.)	S04438
802A	Nut, Hex 5/8 - 11 (12 Req.)	S23109
802B	Nut, Hex 3/8 - 16 (2 Req.)	S23343
805	Washer, Lock	S23038
810	Plug, Pipe 1/2 NPT (4 Req.)	S23717
811	Fitting, Grease	S23700
812	Elbow, Street	S25421
•	Plug, Pipe 1/4 NPT (2 Req) (Not Illustrated)	S23715

**TABLE II**

HP	PH	Bracket No.	"AK" Fit	"U" Dim.	Motor Frame
60	3	H03622	12-1/2"	1-5/8"	364JP
75	3	H03622	12-1/2"	1-5/8"	365JP

**NOTE:** For an explanation of the tabulated material found on this page and for impeller key location, refer to *Supplement A* located at the beginning of this section.



# TYPE "B" SINGLE STAGE CENTRIFUGAL PUMP Electric Motor Drive

Section	CC
Page	420.4
Date	January 1, 2004
Supersedes 6/1/95	

## CAST IRON IMPELLER

## B8GPBM

### Flanged Case

### Packing Construction

TABLE I

B/M No.	HP	PH	RPM	"U" Dim.	Imp. Dia.	Imp. No.
B56001	100	3	1800	1-5/8"	11.94"	M07776
B75241	125	3	1800	1-5/8"	12.13"	M03798

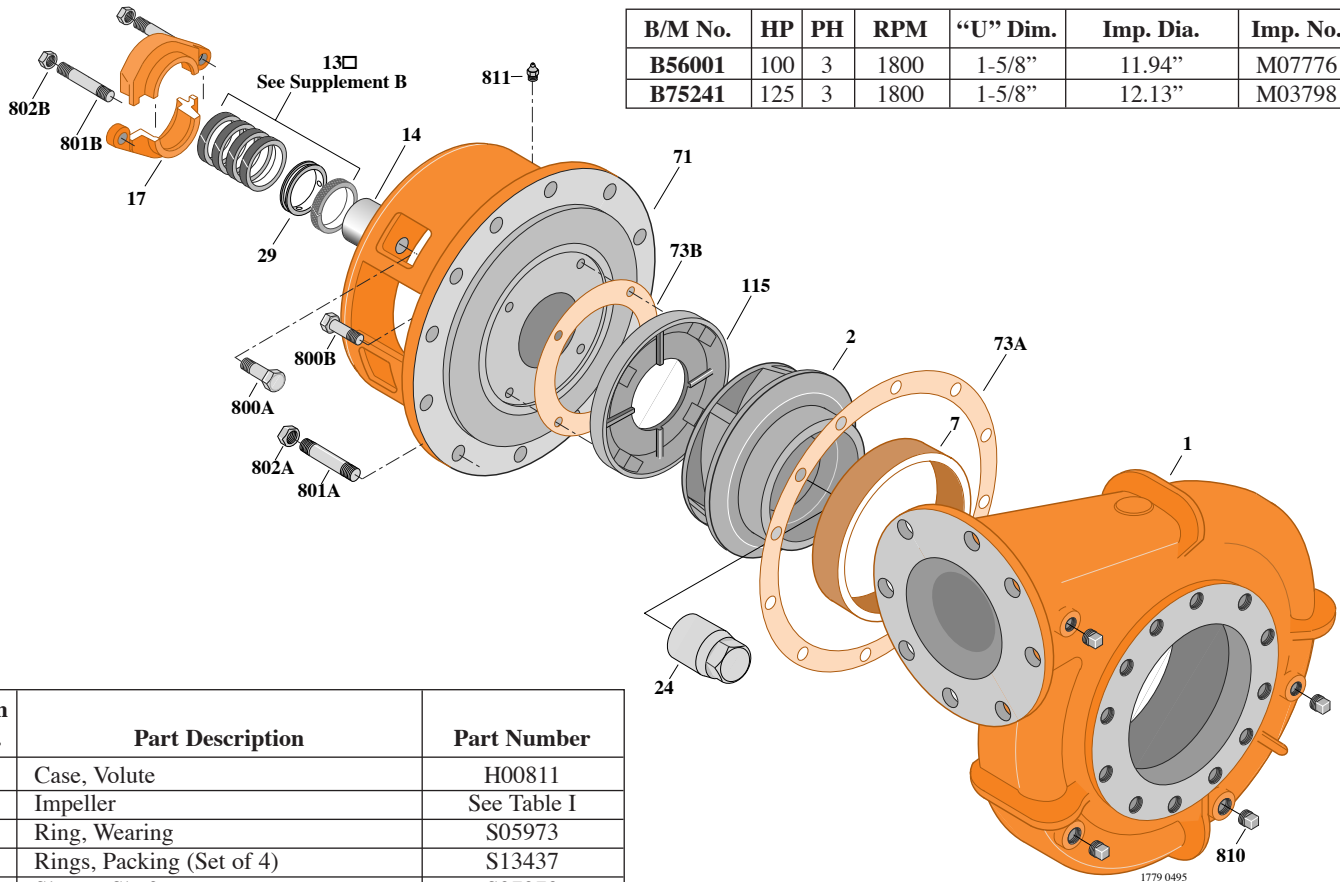

Item No.	Part Description	Part Number
1	Case, Volute	H00811
2	Impeller	See Table I
7	Ring, Wearing	S05973
13	Rings, Packing (Set of 4)	S13437
14	Sleeve, Shaft	S07073
17	Gland, Packing	B82471
24	Locknut, Impeller	S07829
29	Ring, Lantern	S19198
32	Key, 3/8 x 2-1/4" (See Note)	S23940
71	Bracket	See Table II
73A	Gasket, Volute Case	S06271
73B	Gasket, Balance Ring	S09943
115	Ring, Balance	S14065
800A	Capscrew, 5/8 - 11 x 1-3/4" (8 Req.)	S27001
800B	Capscrew, 3/8 - 16 x 1-1/2" (4 Req.)	S26830
801A	Stud, 5/8 - 11 x 2-1/4" (12 Req.)	S24061
801B	Stud, 3/8 - 16 x 2-1/2" (2 Req.)	S04438
802A	Nut, Hex 5/8 - 11 (12 Req.)	S23109
802B	Nut, Hex 3/8 - 16 (2 Req.)	S23343
810	Plug, Pipe 1/2 NPT (4 Req.)	S23717
811	Fitting, Grease	S23700
812	Elbow, Street	S25421
•	Plug, Pipe 1/4 NPT (2 Req.) (Not Illustrated)	S23715

TABLE II

HP	PH	Bracket No.	"AK" Fit	"U" Dim.	Motor Frame
100	3	H03622	12-1/2"	1-5/8"	404TC
125	3	H03622	12-1/2"	1-5/8"	405TC

**NOTE:** For an explanation of the tabulated material found on this page and for impeller key location, refer to *Supplement A* located at the beginning of this section.



# TYPE "B" SINGLE STAGE CENTRIFUGAL PUMP Electric Motor Drive

Section	CC
Page	420.5
Date	January 1, 2004
Supersedes 6/1/95	

## CAST IRON IMPELLER

## B8GPBMS

### Flanged Case

### Mechanical Shaft Seal Construction

**TABLE I**

B/M No.	HP	PH	RPM	"U" Dim.	Imp. Dia.	Imp. No.
B54227	15	3	1200	1-1/4"	9.38"x10.62"	M07772
B54228	20	3	1200	1-1/4"	10.62"x11.12"	M07773
B54229	25	3	1200	1-1/4"	11.50"	M07771
B54230	30	3	1200	1-1/4"	12.12"	M03800

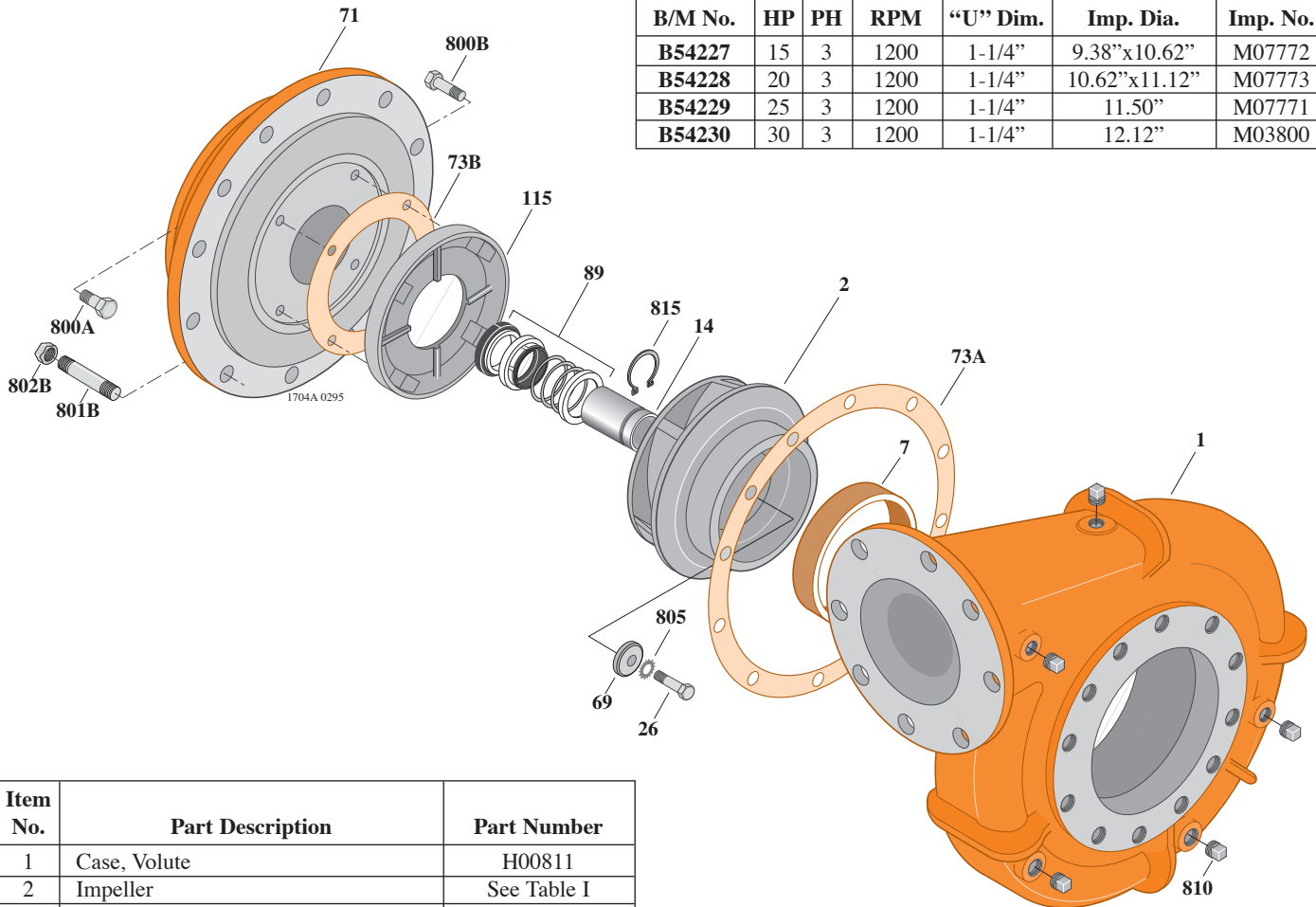

Item No.	Part Description	Part Number
1	Case, Volute	H00811
2	Impeller	See Table I
7	Ring, Wearing	S05973
14	Sleeve, Shaft	S18869
26	Screw, Impeller 1/2 - 13 x 2-3/4"	S23630
32	Key, 1/4 x 2-1/4" (See Note)	S23677
69	Washer, Impeller	S06319
71	Bracket	See Table II
73A	Gasket, Volute Case	S06271
73B	Gasket, Balance Ring	S09943
89	Seal, Mechanical Shaft	S32015
115	Ring, Balance	S19073
800A	Capscrew, 5/8 - 11 x 1-1/2" (4 Req.)	S26999
800B	Capscrew, 3/8 - 16 x 1" (4 Req.)	S26826
801	Stud, 5/8 - 11 x 2-1/4" (12 Req.)	S24061
802	Nut, Hex 5/8 - 11 (12 Req.)	S23109
805	Washer, Lock	S23038
810	Plug, Pipe 1/2 NPT (5 Req.)	S23717
815	Ring, Retaining	S16767

**TABLE II**

HP	PH	Bracket No.	"AK" Fit	"U" Dim.	Motor Frame
15	3	H03301	12-1/2"	1-1/4"	284JM
20	3	H03301	12-1/2"	1-1/4"	286JM
25	3	H03301	12-1/2"	1-1/4"	324JM
30	3	H03301	12-1/2"	1-1/4"	326JM

**NOTE:** For an explanation of the tabulated material found on this page and for impeller key location, refer to *Supplement A* located at the beginning of this section.



# TYPE "B" SINGLE STAGE CENTRIFUGAL PUMP Electric Motor Drive

Section	CC
Page	420.6
Date	January 1, 2004
Supersedes 6/1/95	

## CAST IRON IMPELLER

## B8GPBMS

### Flanged Case

### Mechanical Shaft Seal Construction

TABLE I

B/M No.	HP	PH	RPM	"U" Dim.	Imp. Dia.	Imp. No.
B54231	40	3	1800	1-1/4"	8.62"x10.18"	M07769
B54232	50	3	1800	1-1/4"	9.44"x10.62"	M07770

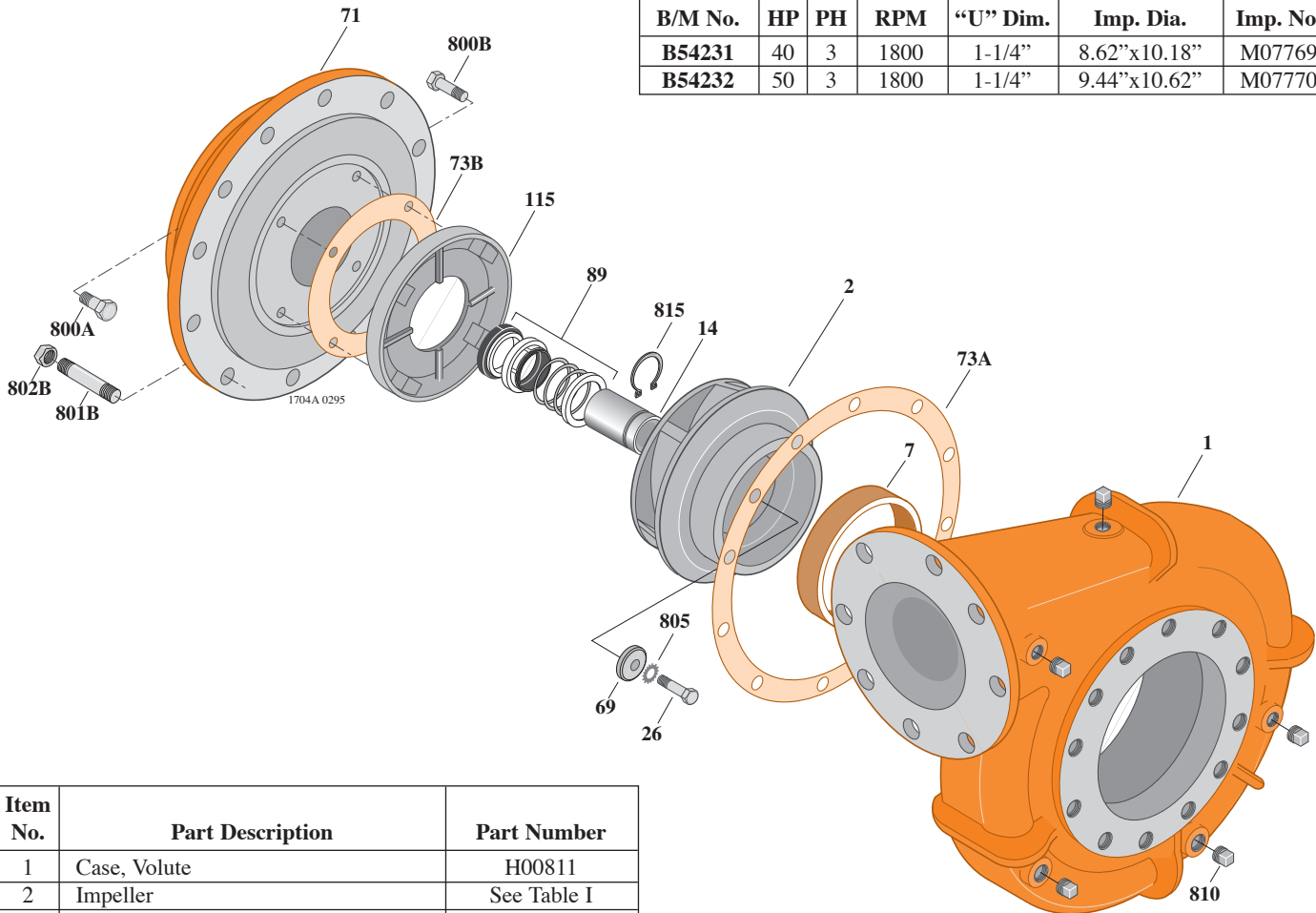

Item No.	Part Description	Part Number
1	Case, Volute	H00811
2	Impeller	See Table I
7	Ring, Wearing	S05973
14	Sleeve, Shaft	S18869
26	Screw, Impeller 1/2 - 13 x 2-3/4"	S23630
32	Key, 1/4 x 2-1/4" (See Note)	S23677
69	Washer, Impeller	S06319
71	Bracket	See Table II
73A	Gasket, Volute Case	S06271
73B	Gasket, Balance Ring	S09943
89	Seal, Mechanical Shaft	S32015
115	Ring, Balance	S19073
800A	Capscrew, 5/8 - 11 x 1-1/2" (4 Req.)	S26999
800B	Capscrew, 3/8 - 16 x 1" (4 Req.)	S26826
801	Stud, 5/8 - 11 x 2-1/4" (12 Req.)	S24061
802	Nut, Hex 5/8 - 11 (12 Req.)	S23109
805	Washer, Lock	S23038
810	Plug, Pipe 1/2 NPT (5 Req.)	S23717
815	Ring, Retaining	S16767

TABLE II

HP	PH	Bracket No.	"AK" Fit	"U" Dim.	Motor Frame
40	3	H03301	12-1/2"	1-1/4"	324JM
50	3	H03301	12-1/2"	1-1/4"	326JM

**NOTE:** For an explanation of the tabulated material found on this page and for impeller key location, refer to *Supplement A* located at the beginning of this section.





# TYPE "B" SINGLE STAGE CENTRIFUGAL PUMP Electric Motor Drive

Section	CC
Page	420.8
Date	January 1, 2004
Supersedes 6/1/95	

## CAST IRON IMPELLER

## B8GPBMS

### Flanged Case

### Mechanical Shaft Seal Construction

TABLE I

B/M No.	HP	PH	RPM	"U" Dim.	Imp. Dia.	Imp. No.
B61666	100	3	1800	1-5/8"	11.94"	M07776
B75242	125	3	1800	1-5/8"	12.13"	M03798

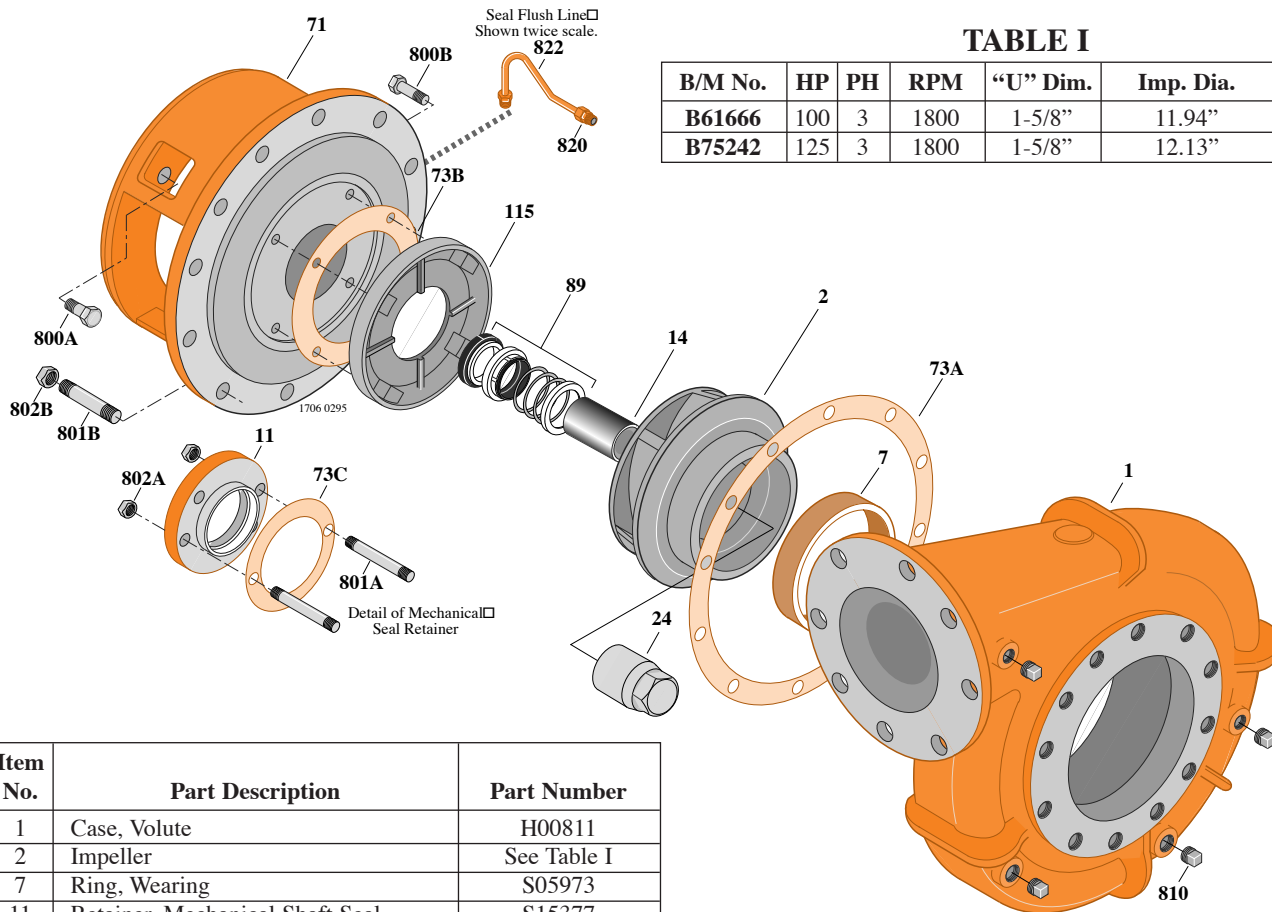

Item No.	Part Description	Part Number
1	Case, Volute	H00811
2	Impeller	See Table I
7	Ring, Wearing	S05973
11	Retainer, Mechanical Shaft Seal	S15377
14	Sleeve, Shaft	S07073
24	Nut, Impeller	S07829
32	Key, 3/8 x 2-1/4" (See Note)	S23940
71	Bracket	See Table II
73A	Gasket, Volute Case	S06271
73B	Gasket, Balance Ring	S09943
73C	Gasket, Seal Retainer	S16411
89	Seal, Mechanical Shaft	S32016
115	Ring, Balance	S14065
800A	Cap screw, 5/8 - 11 x 1-3/4" (8 Req.)	S27001
800B	Cap screw, 3/8 - 16 x 1-1/2" (4 Req.)	S26830
801A	Stud, 3/8 - 16 x 2-1/2" (2 Req.)	S04438
801B	Stud, 5/8 - 11 x 2-1/4" (12 Req.)	S24061
802A	Nut, Hex 3/8 - 16 (2 Req.)	S23343
802B	Nut, Hex 5/8 - 11 (12 Req.)	S23109
810	Plug, Pipe 1/2 NPT (4 Req.)	S23717
820	Connector, Comp. Fitting (2 Req.)	S24013
822	Tubing, Copper	S20677
•	Plug, Pipe 1/4 NPT (Not Illustrated)	S14692
•	Plug, Pipe 1/8 NPT (Not Illustrated)	S23714

TABLE II

HP	PH	Bracket No.	"AK" Fit	"U" Dim.	Motor Frame
100	3	H03936	12-1/2"	1-5/8"	404TC
125	3	H03936	12-1/2"	1-5/8"	405TC

**NOTE:** For an explanation of the tabulated material found on this page and for impeller key location, refer to *Supplement A* located at the beginning of this section.





# TYPE "B" SINGLE STAGE CENTRIFUGAL PUMP Electric Motor Drive

Section	CC
Page	420.9
Date	January 1, 2004
Supersedes 9/1/97	

## SILICON BRONZE IMPELLER

## B8GPBM

### Flanged Case

### Packing Construction

TABLE I

B/M No.	HP	PH	RPM	"U" Dim.	Imp. Dia.	Imp. No.
B75255	40	3	1200	1-1/4"	12.12"	M03798

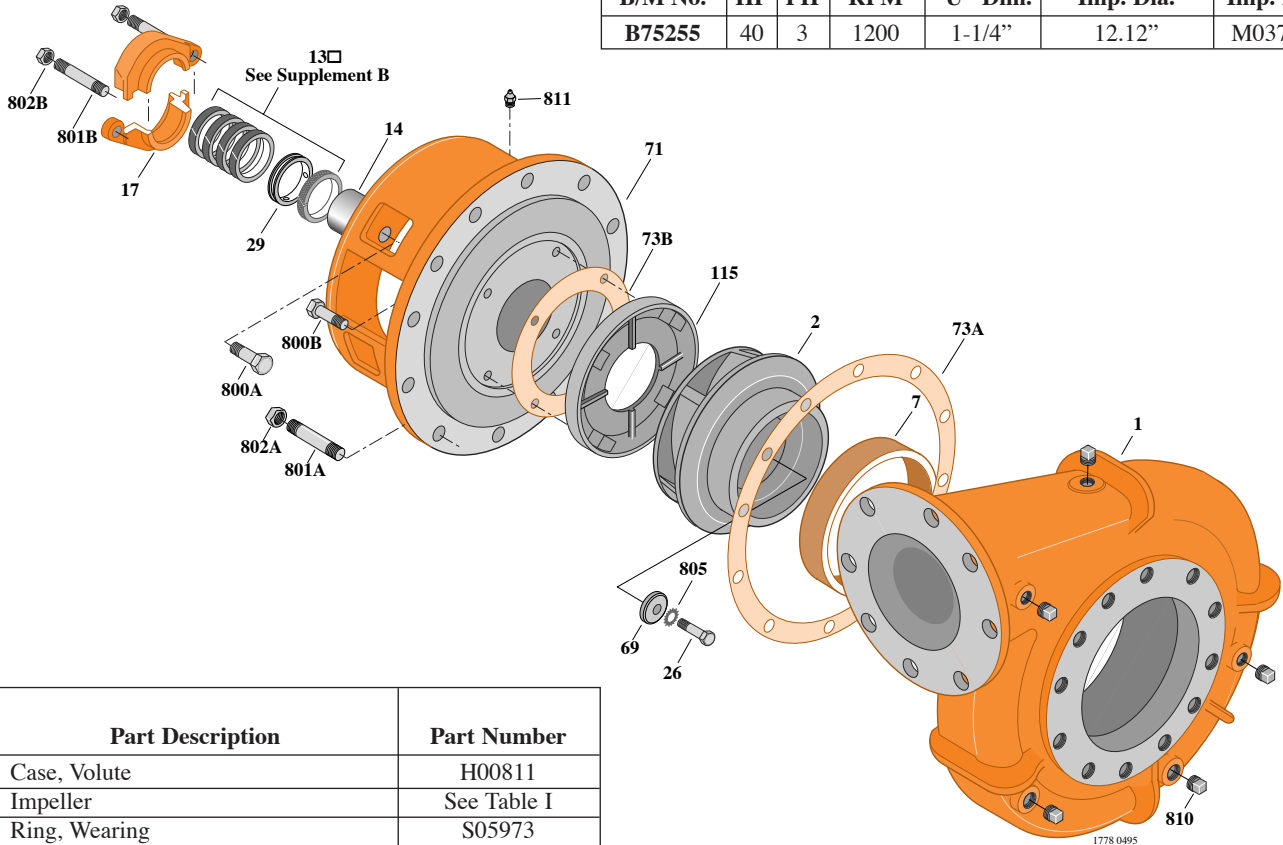

Item No.	Part Description	Part Number
1	Case, Volute	H00811
2	Impeller	See Table I
7	Ring, Wearing	S05973
13	Rings, Packing (Set of 4)	S13437
14	Sleeve, Shaft	S07073
17	Gland, Packing	B82471
26	Screw, Impeller 1/2 - 13 x 1-1/4"	S23621
29	Ring, Lantern	S19198
32	Key, 3/8 x 2-1/4" (See Note)	S23940
69	Washer, Impeller	S34492
71	Bracket	See Table II
73A	Gasket, Volute Case	S06271
73B	Gasket, Balance Ring	S09943
115	Ring, Balance	S14065
800A	Capscrew, 5/8 - 11 x 1-3/4" (4 Req.)	S27001
800B	Capscrew, 3/8 - 16 x 1-1/2" (4 Req.)	S26830
801A	Stud, 5/8 - 11 x 2-1/4" (12 Req.)	S24061
801B	Stud, 3/8 - 16 x 2-1/2" (2 Req.)	S04438
802A	Nut, Hex 5/8 - 11 (12 Req.)	S23109
802B	Nut, Hex 3/8 - 16 (2 Req.)	S23343
805	Washer, Lock	S23038
810	Plug, Pipe 1/2" NPT (5 Req.)	S23717
811	Fitting, Grease	S23700

TABLE II

HP	PH	Bracket No.	"AK" Fit	"U" Dim.	Motor Frame
40	3	H03622	12-1/2"	1-1/4"	364TCZ

**NOTE:** For an explanation of the tabulated material found on this page and for impeller key location, refer to *Supplement A* located at the beginning of this section.



# TYPE "B" SINGLE STAGE CENTRIFUGAL PUMP Electric Motor Drive

Section	CC
Page	420.10
Date	January 1, 2004
Supersedes 9/1/97	

## SILICON BRONZE IMPELLER

## B8GPBMS

### Flanged Case

### Mechanical Shaft Seal Construction

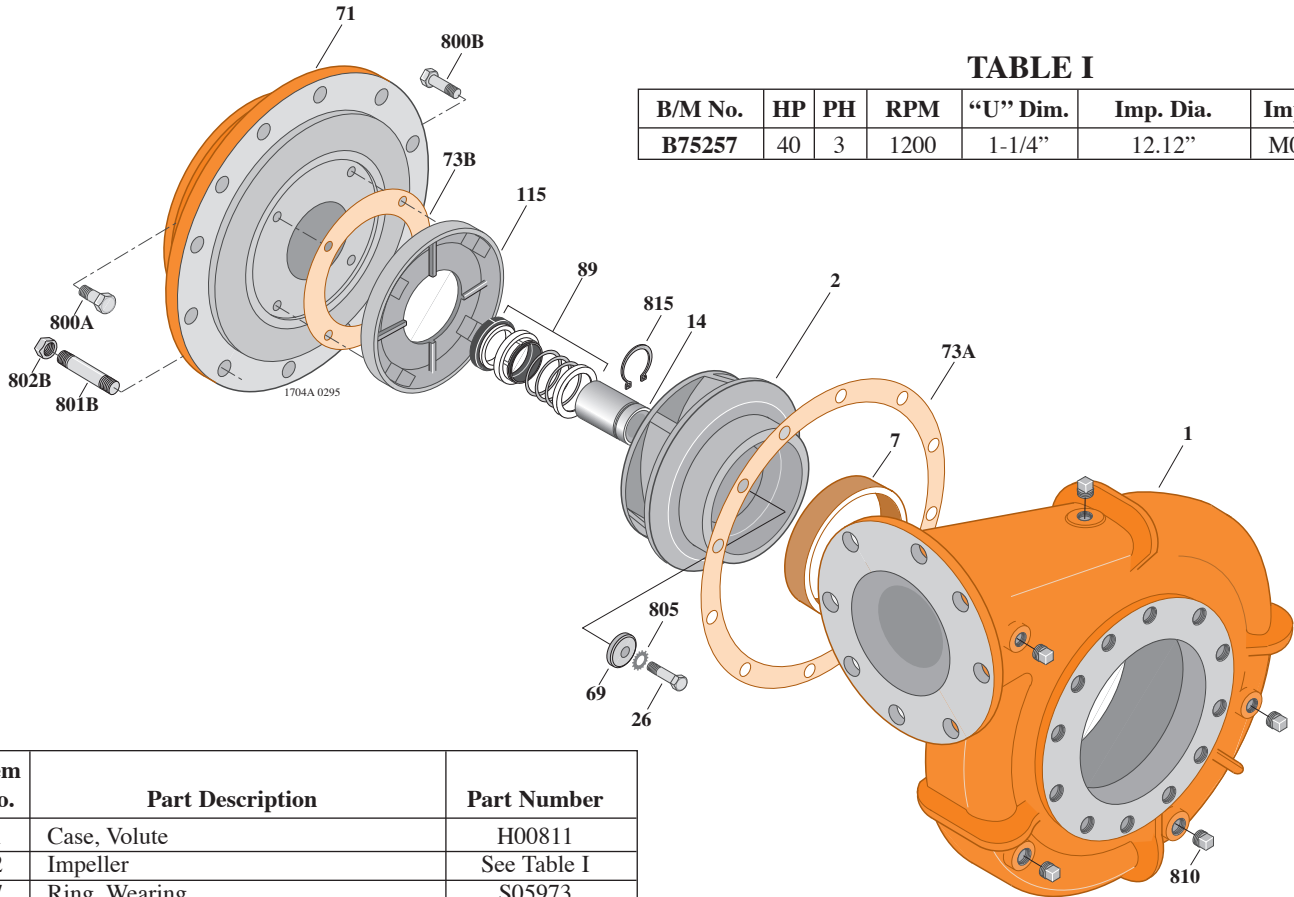

TABLE I

B/M No.	HP	PH	RPM	"U" Dim.	Imp. Dia.	Imp. No.
B75257	40	3	1200	1-1/4"	12.12"	M03798

Item No.	Part Description	Part Number
1	Case, Volute	H00811
2	Impeller	See Table I
7	Ring, Wearing	S05973
11	Retainer, Mechanical Shaft Seal	S15377
14	Sleeve, Shaft	S07073
26	Screw, Impeller 1/2 - 13 x 1-1/4"	S23621
32	Key, 3/8 x 2-1/4" (See Note)	S23940
69	Washer, Impeller	S34492
71	Bracket	See Table II
73A	Gasket, Volute Case	S06271
73B	Gasket, Balance Ring	S09943
73C	Gasket, Mechanical Shaft Seal Retainer	S15078
89	Seal, Mechanical Shaft	S32016
115	Ring, Balance	S14065
800A	Capscrew, 5/8 - 11 x 1-3/4" (4 Req.)	S27001
800B	Capscrew, 3/8 - 16 x 1-1/2" (4 Req.)	S26830
801A	Stud, 3/8 - 16 x 2-1/2" (2 Req.)	S04438
801B	Stud, 5/8 - 11 x 2-1/4" (12 Req.)	S24061
802A	Nut, Hex 3/8 - 16 (2 Req.)	S23343
802B	Nut, Hex 5/8 - 11 (12 Req.)	S23109
805	Washer, Lock	S23038
810	Plug, Pipe 1/2" NPT (5 Req.)	S23717
•	Plug, Pipe 1/8" NPT(In Bracket)(2 Req.)	S23714

TABLE II

HP	PH	Bracket No.	"AK" Fit	"U" Dim.	Motor Frame
40	3	H03301	12-1/2"	1-1/4"	364JMZ

**NOTE:** For an explanation of the tabulated material found on this page and for impeller key location, refer to *Supplement A* located at the beginning of this section.

**NOTE:** For seal flush line details, see *Supplement D*.

• Not illustrated.



# TYPE "B" SINGLE STAGE CENTRIFUGAL PUMP Electric Motor Drive

Section	CC
Page	420.11
Date	January 1, 2004
Supersedes /New	

**BRONZE IMPELLER**

**B8GPBMS**

**Flanged Case**

**Mechanical Shaft Seal Construction**

**TABLE I**

B/M No.	HP	PH	RPM	"U" Dim.	Imp. Dia.	Imp. No.
<b>B76785</b>	40	3	1800	1-1/4"	8.62"x10.18"	M11573
<b>B76786</b>	50	3	1800	1-1/4"	9.44"x10.62"	M11574

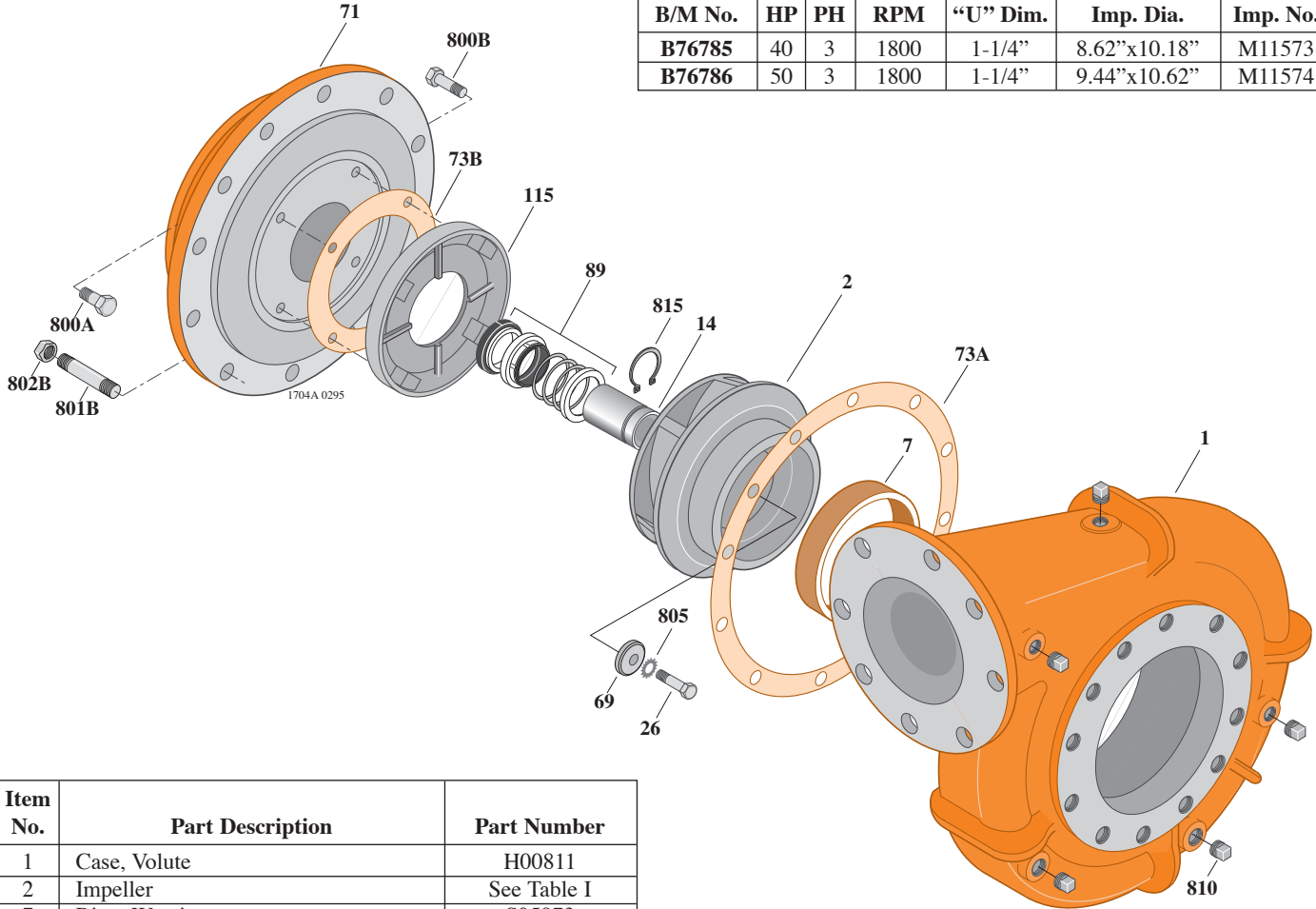

Item No.	Part Description	Part Number
1	Case, Volute	H00811
2	Impeller	See Table I
7	Ring, Wearing	S05973
14	Sleeve, Shaft	S18869
26	Screw, Impeller 1/2 - 13 x 2-3/4"	S23630
32	Key, 1/4 x 2-1/4" (See Note)	S23677
69	Washer, Impeller	S06319
71	Bracket	See Table II
73A	Gasket, Volute Case	S06271
73B	Gasket, Balance Ring	S09943
89	Seal, Mechanical Shaft	S32015
115	Ring, Balance	S19073
800A	Capscrew, 5/8 - 11 x 1-1/2" (4 Req.)	S26999
800B	Capscrew, 3/8 - 16 x 1" (4 Req.)	S26826
801	Stud, 5/8 - 11 x 2-1/4" (12 Req.)	S24061
802	Nut, Hex 5/8 - 11 (12 Req.)	S23109
805	Washer, Lock	S23038
810	Plug, Pipe 1/2 NPT (5 Req.)	S23717
815	Ring, Retaining	S16767

**TABLE II**

HP	PH	Bracket No.	"AK" Fit	"U" Dim.	Motor Frame
40	3	H03301	12-1/2"	1-1/4"	324JM
50	3	H03301	12-1/2"	1-1/4"	326JM

**NOTE:** For an explanation of the tabulated material found on this page and for impeller key location, refer to *Supplement A* located at the beginning of this section.



# TYPE "B" SINGLE STAGE CENTRIFUGAL PUMP Electric Motor Drive

Section	CC
Page	420.12
Date	January 1, 2004
Supersedes/New	

## BRONZE IMPELLER

## B8GPBMS

### Flanged Case

### Mechanical Shaft Seal Construction

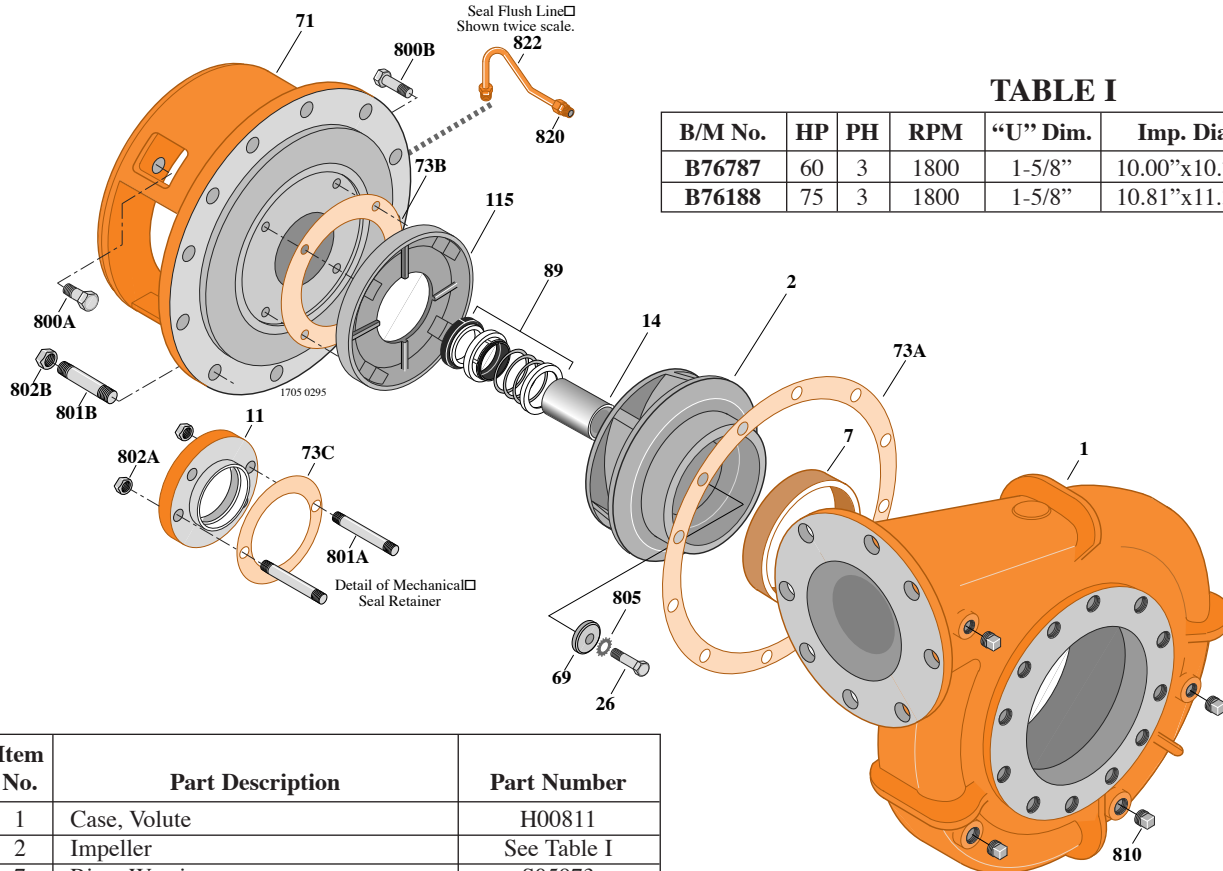

TABLE I

B/M No.	HP	PH	RPM	"U" Dim.	Imp. Dia.	Imp. No.
B76787	60	3	1800	1-5/8"	10.00"x10.75"	M11575
B76188	75	3	1800	1-5/8"	10.81"x11.38"	M11576

Item No.	Part Description	Part Number
1	Case, Volute	H00811
2	Impeller	See Table I
7	Ring, Wearing	S05973
11	Retainer, Mechanical Shaft Seal	S15377
14	Sleeve, Shaft	S07073
26	Screw, Impeller 1/2 - 13 x 1-1/4"	S23621
32	Key, 3/8 x 2-1/4" (See Note)	S23940
69	Washer, Impeller	S34492
71	Bracket	See Table II
73A	Gasket, Volute Case	S06271
73B	Gasket, Balance Ring	S09943
73C	Gasket, Seal Retainer	S16411
89	Seal, Mechanical Shaft	S32016
115	Ring, Balance	S14065
800A	Capscrew, 5/8 - 11 x 1-3/4" (4 Req.)	S27001
800B	Capscrew, 3/8 - 16 x 1-1/2" (4 Req.)	S26830
801A	Stud, 3/8 - 16 x 2-1/2" (2 Req.)	S04438
801B	Stud, 5/8 - 11 x 2-1/4" (12 Req.)	S24061
802A	Nut, Hex 3/8 - 16 (2 Req.)	S23343
802B	Nut, Hex 5/8 - 11 (12 Req.)	S23109
805	Washer, Lock	S23038
810	Plug, Pipe 1/2 NPT (4 Req.)	S23717
820	Connector, Comp. Fitting (2 Req.)	S24013
822	Tubing, Copper	S20677
	• Plug, Pipe 1/8 NPT (Not Illustrated)	S23714
	• Plug, Pipe 1/4 NPT (Not Illustrated)	S23715

TABLE II

HP	PH	Bracket No.	"AK" Fit	"U" Dim.	Motor Frame
60	3	H03936	12-1/2"	1-5/8"	364JP
75	3	H03936	12-1/2"	1-5/8"	365JP

**NOTE:** For an explanation of the tabulated material found on this page and for impeller key location, refer to *Supplement A* located at the beginning of this section.

