

BALDOR • RELIANCE

Customer information packet

IDVSNM3587T

2HP, 1755RPM, 3PH, 60HZ, 143TC, 0534M, TENV, F1

Class - None

Division - Not Applicable

Specifications

Enclosure	TENV
Frame	145TC
Frame Material	Iron
Frequency	60.00 Hz
Haz Area Class and Group	None
Haz Area Division	Not Applicable
Motor Letter Type	Three Phase
Output @ Frequency	2.000 HP @ 60 HZ
Phase	3
Synchronous Speed @ Frequency	1800 RPM @ 60 HZ
Voltage @ Frequency	230.0 V @ 60 HZ 460.0 V @ 60 HZ
Agency Approvals	CSA UR
Ambient Temperature	40 °C
Auxillary Box	No Auxillary Box
Auxillary Box Lead Termination	None
Base Indicator	Rigid
Bearing Grease Type	Polyrex EM (-20F +300F)
Blower	None
Current @ Voltage	5.400 A @ 230.0 V 2.700 A @ 460.0 V
Design Code	B
Drip Cover	No Drip Cover
Duty Rating	CONT
Efficiency @ 100% Load	86.5 %
Electrically Isolated Bearing	Not Electrically Isolated
Feedback Device	NO FEEDBACK
Front Shaft Indicator	None
Heater Indicator	No Heater
High Voltage Full Load Amps	2.7 a
Insulation Class	F

Part detail

Revision	A
Type	AC
Mech. spec.	05E534
Base	
Status	PRD/A
Elec. spec.	05WGX544
Layout	05LYE534
Eff. date	02-28-2023
CD Diagram	CD0005
Poles	04
Leads	9#18
Proprietary	False
Created date	03-11-2022

Inverter Code	Inverter Ready
KVA Code	M
Lifting Lugs	Standard Lifting Lugs
Locked Bearing Indicator	Locked Bearing
Max Speed	5500 rpm
Motor Lead Quantity/Wire Size	9 @ 18 AWG
Motor Lead Termination	Flying Leads
Motor Standards	NEMA
Motor Type	0534M
Mounting Arrangement	F1
Number of Poles	4
Overall Length	14.65 IN
Power Factor	79
Product Family	General Purpose
Pulley End Bearing Type	Ball
Pulley Face Code	C-Face
Pulley Shaft Indicator	Standard
Rodent Screen	None
Service Factor	1.00
Shaft Diameter	0.875 IN
Shaft Ground Indicator	No Shaft Grounding
Shaft Rotation	Reversible
Shaft Slinger Indicator	No Slinger
Speed	1755 rpm
Speed Code	Single Speed
Starting Method	Direct on line
Thermal Device - Bearing	None
Thermal Device - Winding	Normally Closed Thermostat
Vibration Sensor Indicator	No Vibration Sensor
Winding Thermal 1	None
Winding Thermal 2	None

Nameplate

NP3302L			
CAT NO	IDVSNM3587T		
SPEC.	05E534X544G2		
FRAME	145TC	HP	2 TE
VOLTS	230/460		
MAG CUR	3.08/1.54	FLA	5.4/2.7
RPM	1755	RPM MAX	5500
HZ	60	PH	3 CLASS F
SER.F.	1.00	SL HZ	1.37
NEMA-NOM-EFF	86.5	WK2	0.245
RATING	40C AMB-CONT		
DE BRG	6205	ODE BRG	6203
CC	010A	SN	

AC Induction Motor Performance Data

Record # 82062

Typical performance - not guaranteed values

Winding: 05WGX544-R002		Type: 0534M	Enclosure: TENV	
Nameplate Data			460 V, 60 Hz: High Voltage Connection	
Rated Output (HP)	2	Full Load Torque	5.95 LB-FT	
Volts	230/460	Start Configuration	direct on line	
Full Load Amps	5.4/2.7	Breakdown Torque	25.1 LB-FT	
R.P.M.	1755	Pull-up Torque	15.5 LB-FT	
Hz	60 Phase	Locked-rotor Torque	19.7 LB-FT	
NEMA Design Code	B KVA Code	Starting Current	27.1 A	
Service Factor (S.F.)	1	No-load Current	1.63 A	
NEMA Nom. Eff.	86.5 Power Factor	Line-line Res. @ 25°C	8.23 Ω	
Rating - Duty	40C AMB-CONT	Temp. Rise @ Rated Load	85°C	
		Locked-rotor Power Factor	54.6	
		Rotor inertia	0.245 LB-FT ²	

Load Characteristics 460 V, 60 Hz, 2 HP

% of Rated Load	25	50	75	100	125	150
Power Factor	34	54	68	76	81	84
Efficiency	79.6	86.3	87.5	87.2	86.1	84.5
Speed	1788	1780	1771	1761	1749	1737
Line amperes	1.74	1.98	2.37	2.82	3.36	3.95

ABB Motors and Mechanical Inc.

WINDING # 05WGX544

Typical performance - not guaranteed values.

2 HP 3 PH 60 HZ 1755 RPM 460 V 0534M

TORQUES (LB-FT): PO=25.1 PU=15.5 LR=19.7 LRA=27.1

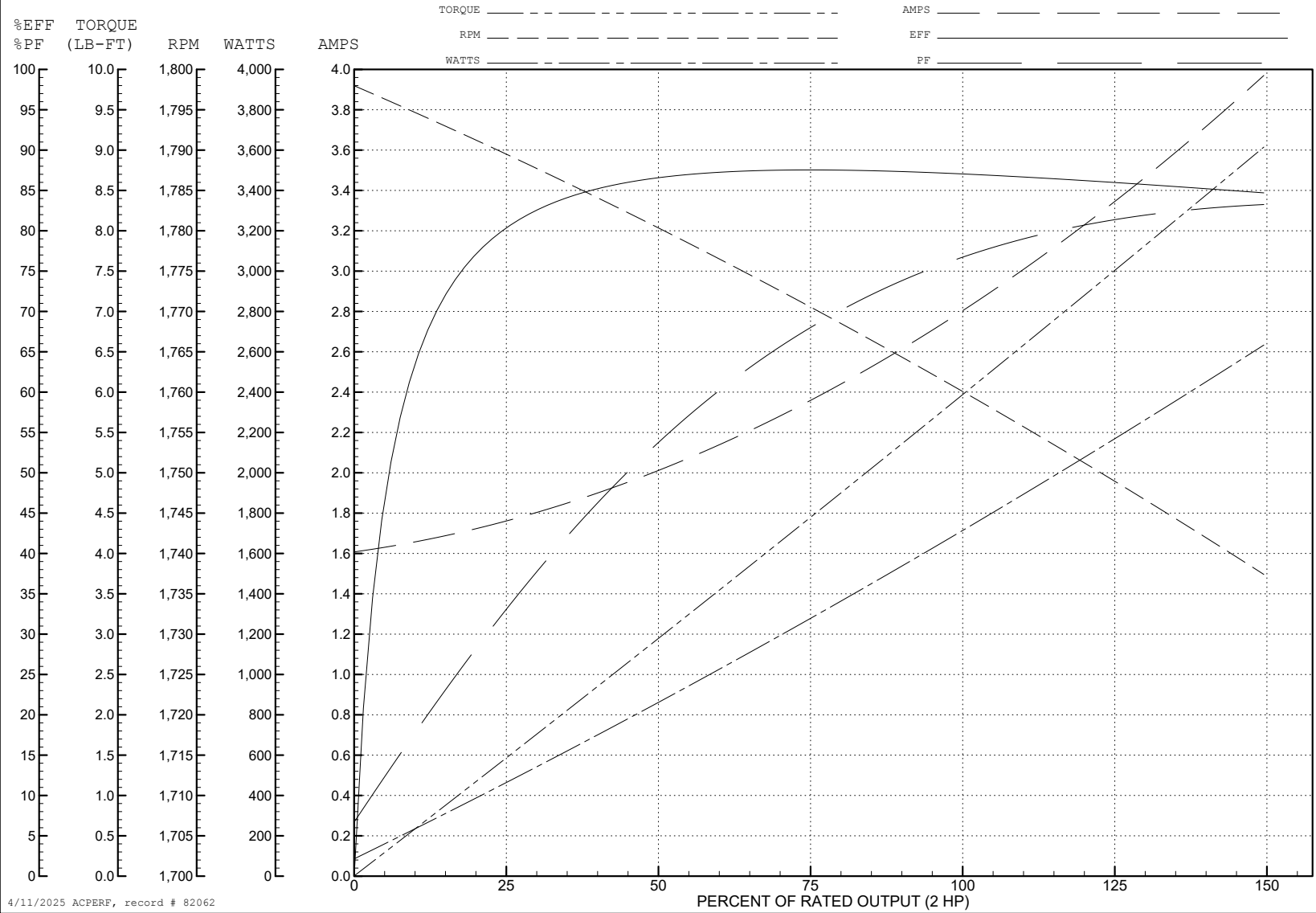

4/11/2025 ACPERF, record # 82062

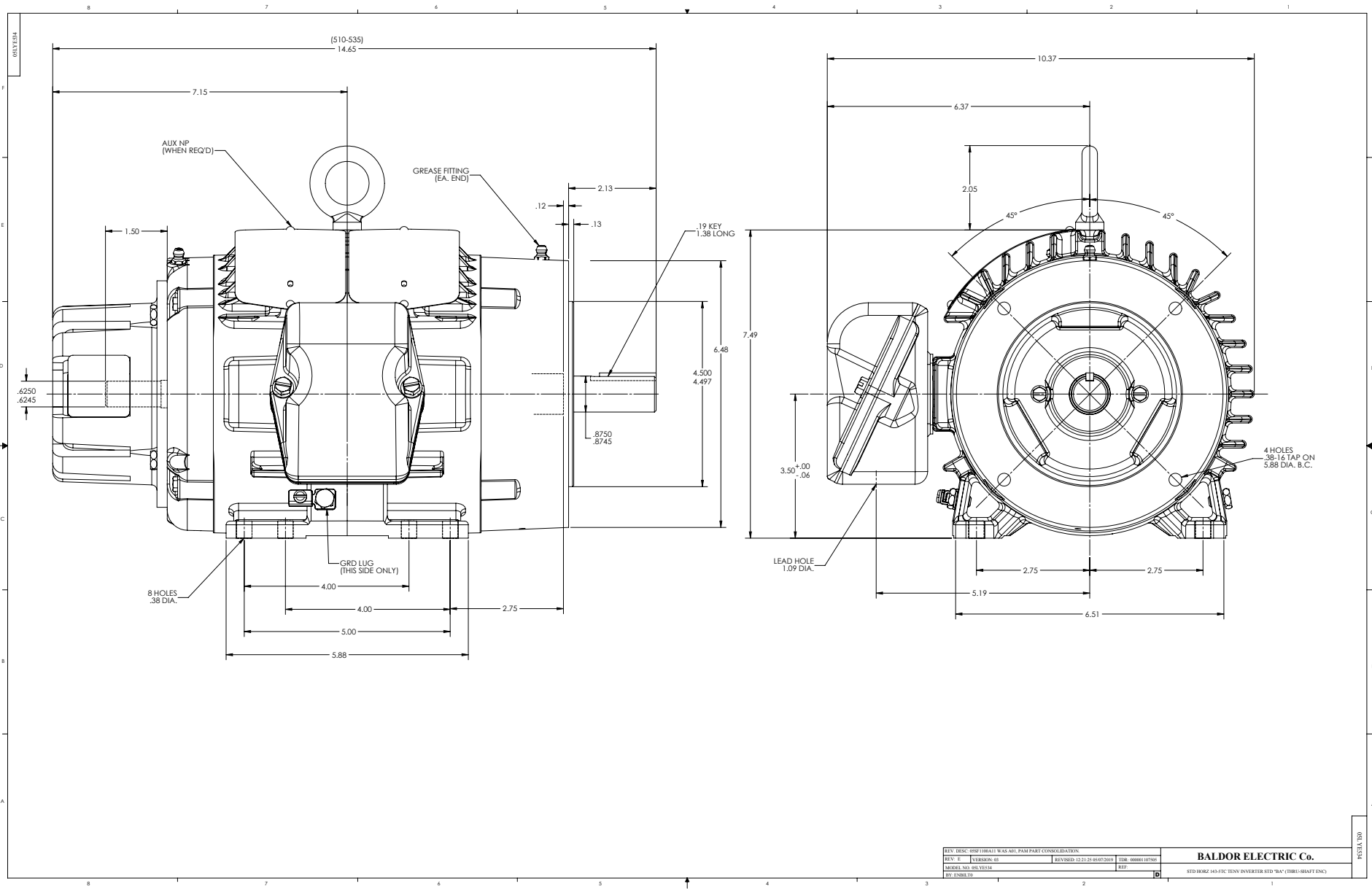

CD0005



LOW VOLTAGE
(2Y)



LINE

HIGH VOLTAGE
(1Y)



LINE

NOTES:

1. INTERCHANGE ANY TWO LINE LEADS TO REVERSE ROTATION.
2. OPTIONAL THERMOSTATS ARE PROVIDED WHEN SPECIFIED.
3. ACTUAL NUMBER OF INTERNAL PARALLEL CIRCUITS MAY BE A MULTIPLE OF THOSE SHOWN ABOVE.
4. LEAD COLORS ARE OPTIONAL. LEADS MUST ALWAYS BE NUMBERED AS SHOWN.

CD0005

REV. DESC: REVISE TO SHOW OPTIONAL COLORS			
REV. LTR: E	BY: JLP	REVISED: 01/19/99 10:15	TDR: 0171435
S00000		FILE: AAA00005140	MDL: -
		MTL: -	

BALDOR ELECTRIC Co.

3PH, DV, 9 LEADS