

291HV-2 (B39)

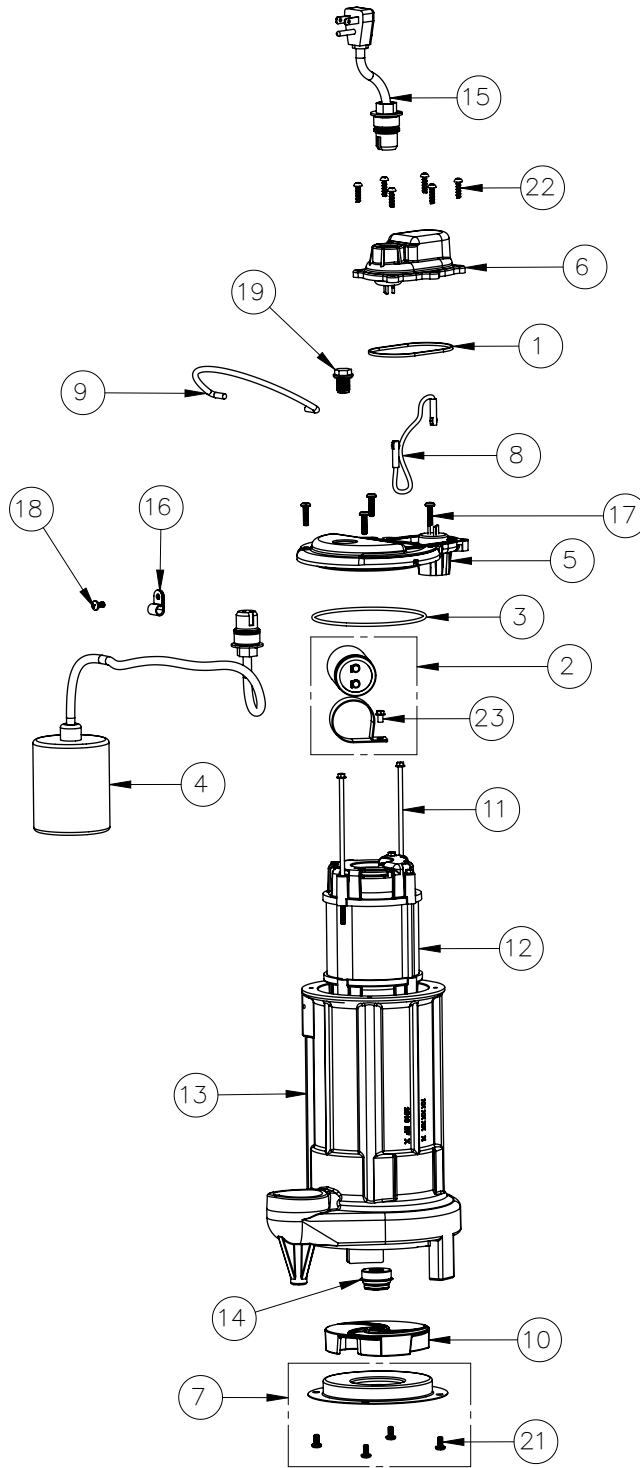

291HV-2

291HV-2 (B39)

#	PART #	DESCRIPTION	QTY	Note
1	K001046	SEALRING, CHAMBER COVER	1	
2	K001354	CAPACITOR KIT	1	
3	2357000	O-RING	1	[1]
4	K001080	2405000 MECHANICAL SWITCH W/ QUICKPLUG	1	
5	240600B	MOTOR COVER	1	
6	240700B	CHAMBER COVER	1	
7	K001349	290 SERIES STAMPING INLET KIT	1	
8	2074000	JUMPER WIRE WITH TERMINALS	1	
9	K001082	HANDLE	1	
10	K001351	290 SERIES IMPELLER KIT	1	
11	2904E20	8-32 SCREW 5.688	2	
12	2426200	MOTOR, 230V	1	[1]
13	290300J	CAST IRON HOUSING	1	[1]
14	50980A0	1/2 INCH UNITIZED SEAL	1	[1]
15	K001008	POWER CORD, 115V, 25 FOOT CORD	1	
16	8014000	CABLE CLAMP	1	
17	8072000	#10 - 24 x 3/4" SCREW	4	
18	8082000	#10-24 x 3/8 EPOXY LOCK SCREW	1	
19	8089000	OIL PLUG, O-RING ASSEMBLY	1	
21	8092000	#10 - 24 x 3/8" SCREW	4	
22	8104200	#10 HILO X 5/8" STAINLESS STEEL SCREW	6	
23	8160000	CAPACITOR SCREW	1	
24	LPOILT1032OZ	REPLACEMENT T10 OIL, QUART BOTTLE (REF 8504000)	1	[2]

PART NOTES:

- [1] - Part requires factory authorized service. Contact Liberty Pumps at 1-800-543-2550
- [2] - Acceptable for use in all liberty Pump's oil-filled products

Acceptable for use in all liberty Pump's oil-filled products