

FL31M-2 (B41)

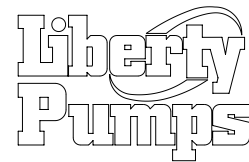
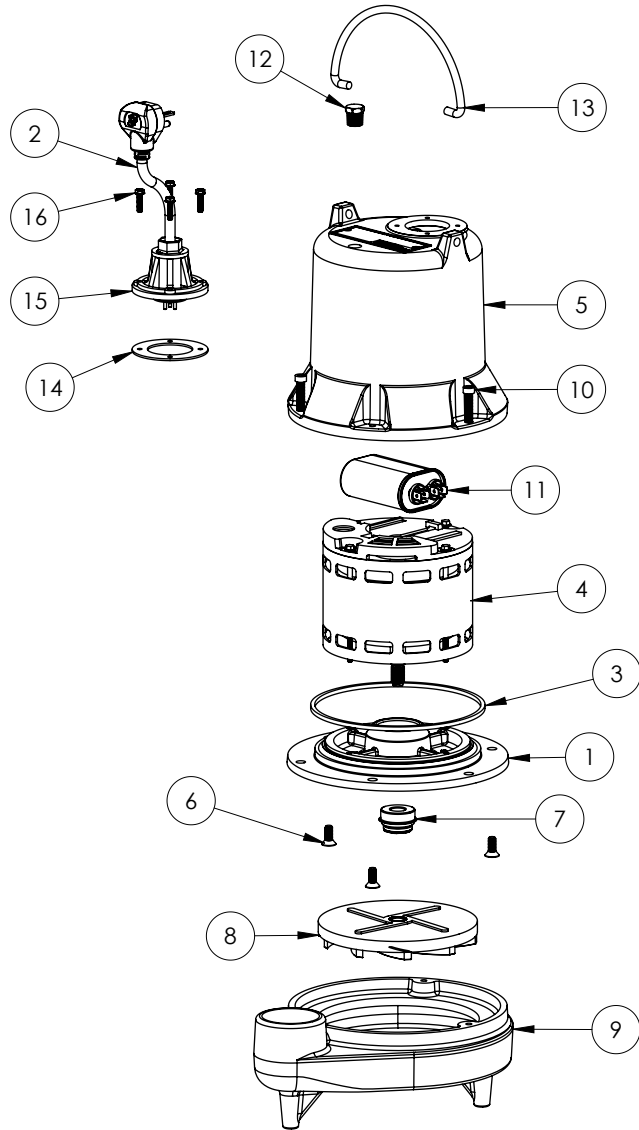

FL31M-2**FL31M-2 (B41)**

#	PART #	DESCRIPTION	QTY	Note
1	509200R	MOTOR SUPPORT PLATE	1	[1]
2	K001008	POWER CORD, 115V, 25 FOOT CORD	1	
3	5066000	SEAL RING, MOTOR COVER, #254S	1	[1]
4	51972A0	MOTOR 1/2HP WITH BALL BEARING	1	[1]
5	527800R	MOTOR CAP	1	[1]
6	8018000	1/4-20 x 5/8 SLOTTED FLAT HEAD BOLT	3	
7	50980A0	1/2 INCH UNITIZED SEAL	1	[1]
8	K001169	IMPELLER	1	
9	500100R	HOUSING, VOLUTE	1	
10	8091000	1/4-20 x 1 HEX SOCKET HEAD BOLT	3	
11	K001756	CAPACITOR 15mF, 370V 105 DEG	1	
12	50710A0	PIPE PLUG, 1/4" HEX HD BRASS NPTF	1	
13	K001095	STAINLESS STEEL HANDLE	1	
14	5060000	CORD PLATE GASKET	1	
15	5014000	CORD PLATE	1	
16	8064000	#8-32 x 5/8 HEX WASHER HEAD SCREW	4	
17	LPOILT1032OZ	REPLACEMENT T10 OIL, QUART BOTTLE (REF 8504000)	1	[2]

PART NOTES:

- [1] - Part requires factory authorized service. Contact Liberty Pumps at 1-800-543-2550
- [2] - Acceptable for use in all liberty Pump's oil-filled products

Acceptable for use in all liberty Pump's oil-filled products