

FL52A-2 (B61)

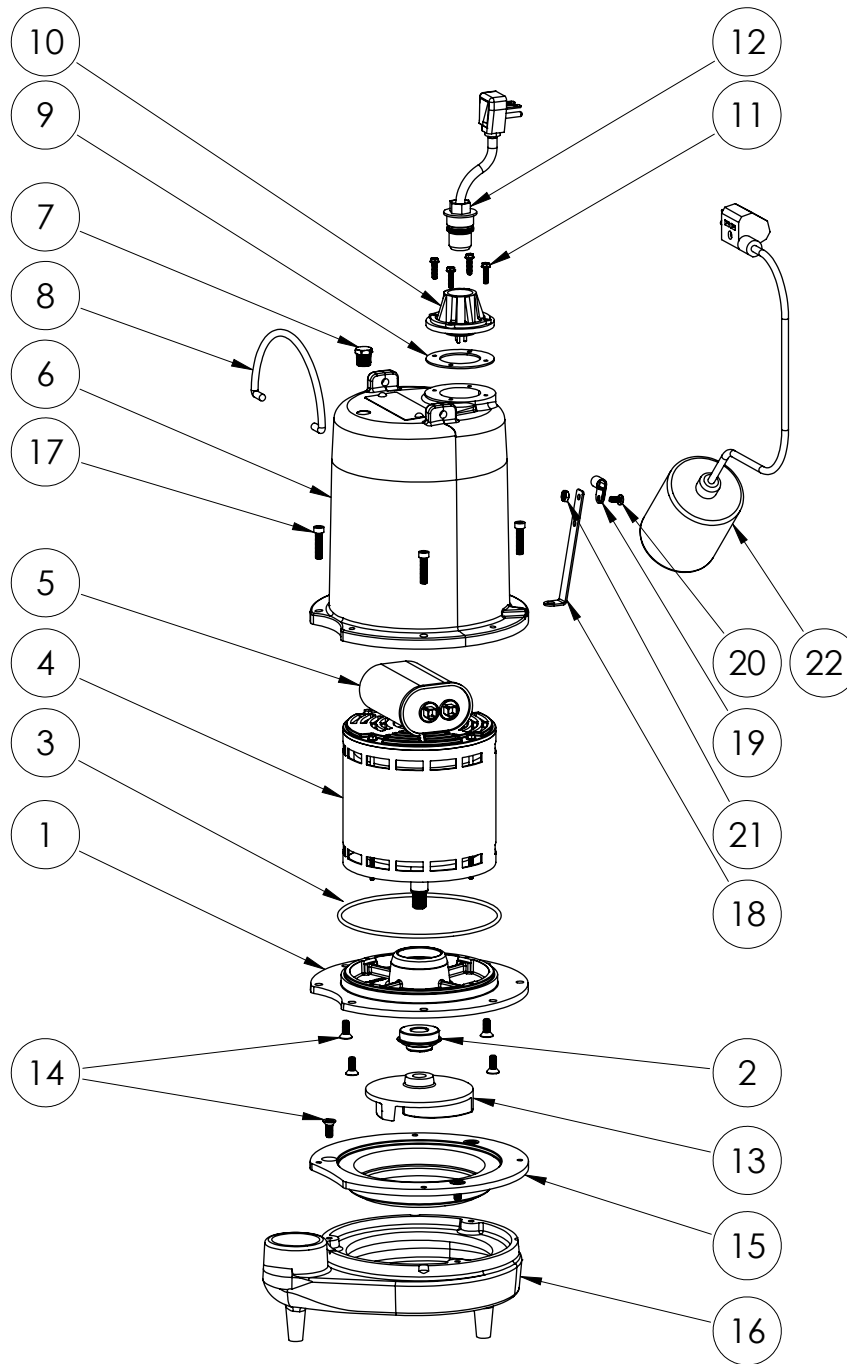

FL52A-2B61

FL52A-2

FL52A-2 (B61)

#	PART #	DESCRIPTION	QTY	Note
1	532600R	MOTOR SUPPORT PLATE	1	
2	K001717	KIT, 5/8 UNITIZED 5120000 AND LIP SEAL 5860000	1	
3	5617000	O-RING	1	
4	5394000	MOTOR	1	[1]
5	53080E0	CAPACITOR	1	[1]
6	531400R	MOTOR COVER	1	[1]
7	50710A0	PIPE PLUG, 1/4" HEX HD BRASS NPTF	1	
8	K001095	STAINLESS STEEL HANDLE	1	
9	5060000	CORD PLATE GASKET	1	
10	5014000	CORD PLATE	1	
11	8064000	#8-32 x 5/8 HEX WASHER HEAD SCREW	4	
12	K001059	POWER CORD, 230V, 25 FOOT CORD	1	
13	53030B0	IMPELLER, CAST IRON	1	
14	8018000	1/4-20 x 5/8 SLOTTED FLAT HEAD BOLT	7	
15	530200R	ADAPTER PLATE	1	
16	530100R	VOLUTE HOUSING	1	
17	8091000	1/4-20 x 1 HEX SOCKET HEAD BOLT	4	
18	5070000	FLOAT SWITCH SUPPORT	1	
19	8067000	CABLE CLAMP	1	
20	8082000	#10-24 x 3/8 EPOXY LOCK SCREW	1	
21	8002000	#10-24 STAINLESS STEEL HEX	1	
22	K001066	FLOAT SWITCH, 230V, 25 FOOT CORD	1	

PART NOTES:

[1] - Part requires factory authorized service. Contact Liberty Pumps at 1-800-543-2550