

FL52M-2 (B78)

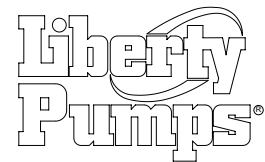
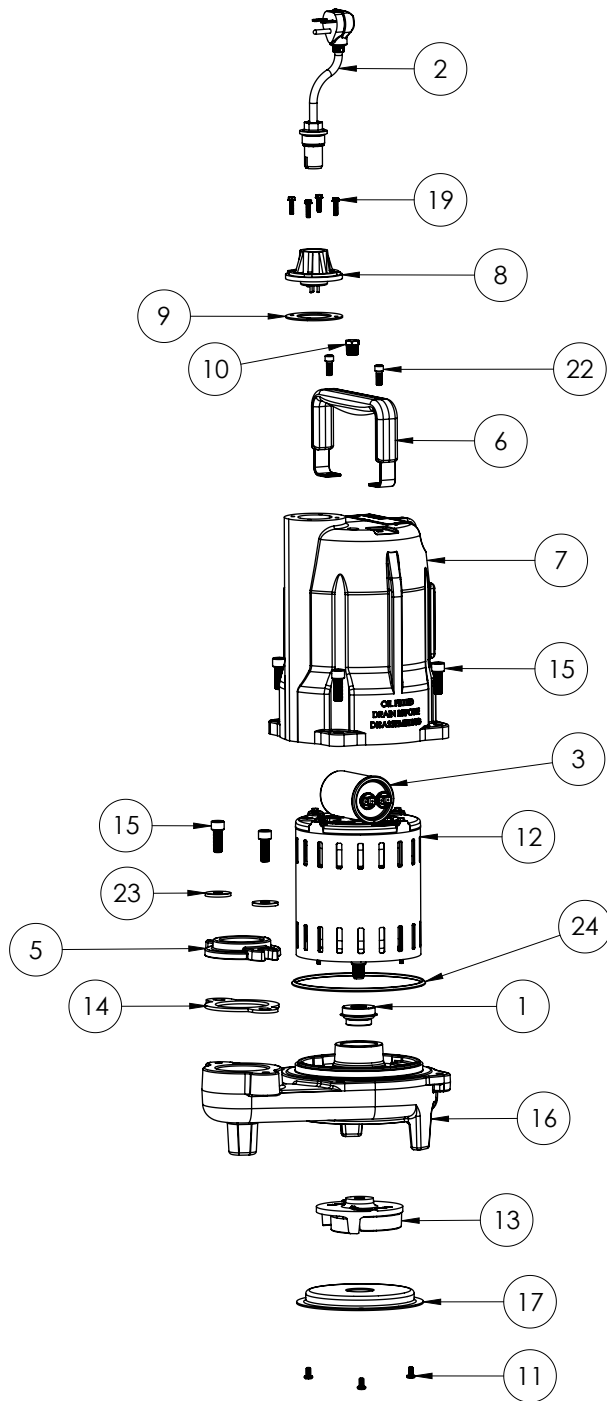

FL52M-2

FL52M-2 (B78)

#	PART #	DESCRIPTION	QTY	Note
1	K001958	KIT 5/8 UNITIZED SEAL 5120000	1	[1]
2	K001059	POWER CORD, 230V, 25 FOOT CORD	1	
3	51960B0	CAPACITOR, 30uF	1	
5	586100R	1.5" ADAPTER FLANGE	1	
6	3411200	HANDLE	1	
7	340000R	MOTOR HOUSING, POWDER COATED	1	
8	5014000	CORD PLATE	1	
9	5060000	CORD PLATE GASKET	1	
10	50710A0	PIPE PLUG, 1/4" HEX HD BRASS NPTF	1	
11	8092000	#10 - 24 x 3/8" SCREW	6	
12	5367000	MOTOR 230V 1PH	1	
13	K002040	KIT FL50 IMPELLER 5833000	1	
14	5858000	1.5" FLANGE GASKET	1	
15	5862000	BOLT, 3/8-16X1 SHCS SS	6	
16	K001408	FL50/60/70 SERIES VOLUTE 588900R	1	
17	K002571	INLET PLATE KIT	1	
19	8064000	#8-32 x 5/8 HEX WASHER HEAD SCREW	4	
22	8103000	SCREW 1/4-20x5/8" HX SKT SS	2	
23	8158000	WASHER, 3/8 x 1-1/8, SS	2	
24	3403000	O-RING	1	
25	LPOILT1032OZ	REPLACEMENT T10 OIL, QUART BOTTLE (REF 8504000)	2	[2]

PART NOTES:

- [1] - Part requires factory authorized service. Contact Liberty Pumps at 1-800-543-2550
Part requires factory authorized service. Contact Liberty Pumps at 1-800-543-2550
- [2] - Acceptable for use in all liberty Pump's oil-filled products

Acceptable for use in all liberty Pump's oil-filled products