

XLE74BM-3

XLE74BM-3 (B90)

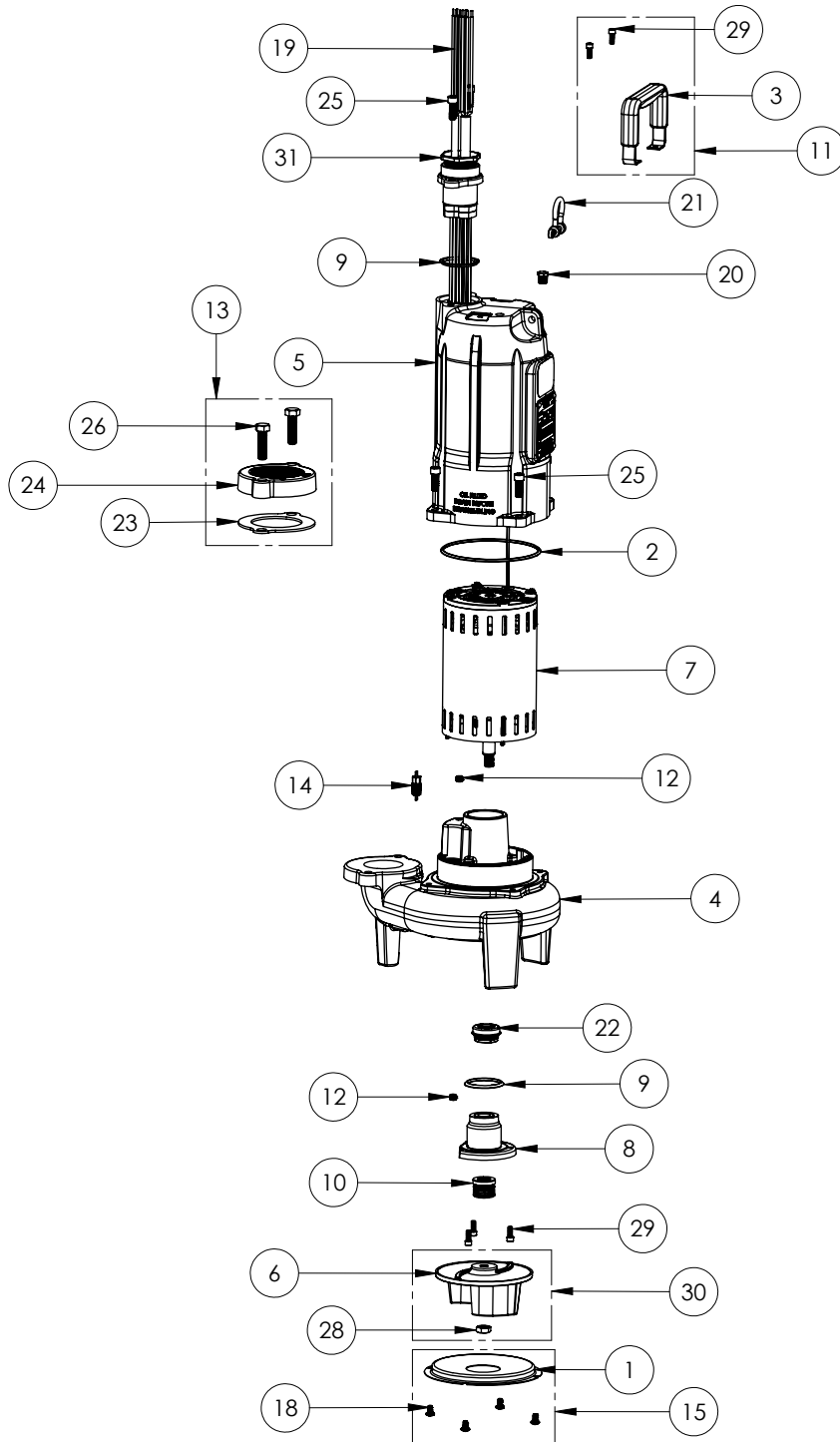

XLE74BM-3**XLE74BM-3 (B90)**

#	PART #	DESCRIPTION	QTY	Note
1	3431000	XLE INLET STAMPING	1	
2	3403000	O-RING	1	
3	3411200	HANDLE	1	
4	341400R	LEX VOLUTE, PAINTED	1	[1]
5	341600R	HOUSING XFL/XLE PAINTED	1	[2]
6	34190A0	XLE70 IMPELLER, MACHINED BRONZE	1	
7	34250A0	MOTOR, 4 POLE 3PH 208/230/4480/480V 60HZ	1	
8	3427000	SEAL PLATE WITH BUSHING	1	[2]
9	3428000	O-RING ASTM 568A- 226	2	
10	3429000	SEAL TYPE 2100 18MM	1	[2]
11	K001681	HANDLE KIT WITH BOLTS	1	
12	34470A0	1/8" STAINLESS STEEL OIL PLUG 18-8	2	
13	K001222	3" DISCHARGE KIT	1	
14	3450000	SEAL FAIL PROBE BODY	1	
15	K001700	XLE INLET PLATE KIT	1	
18	3470000	1/4-20X7/16 PPHMS 18-8	4	
19	34740E0	CORD CAP 35' WITH JUMPER, 4 CONDUCTOR	1	[2]
20	50710A0	PIPE PLUG, 1/4" HEX HD BRASS NPTF	1	
21	K001680	SHACKLE KIT	1	
22	5633000	3/4" UNITIZED SHAFT SEAL	1	[3]
24	512200R	3" DISCHARGE FLANGE	1	
23	5129000	FLANGE GASKET, FITS 2" OR 3"	1	
25	5862000	BOLT, 3/8-16X1 SHCS SS	8	
26	8037000	1/2-13 x 1-3/4 STAINLESS STEEL BOLT	2	
28	8046000	1/2-20 HEX STAINLESS STEEL JAM NUT	1	
29	8103000	SCREW 1/4-20x5/8" HX SKT SS	5	
30	K001701	XLE70 BRONZE IMPELLER KIT	1	
31	3467000	1-1/2" NPT THREADED BUSHING	1	[2]
32	LPOILT1032OZ	REPLACEMENT T10 OIL, QUART BOTTLE (REF 8504000)Replacement Oil for seal probe chamber	1	[4]
33	LPOILT1032OZ	REPLACEMENT T10 OIL, QUART BOTTLE (REF 8504000)Replacement Oil for Motor chamber	3	[4]

PART NOTES:

- [1] - WARNING! These motors are listed for application in Class 1, Division 1, Groups C D, EXPLOSION PROOF environments. The pump must be serviced at the factory or a qualified hazardous motor enclosure repair facility approved by Liberty Pumps. Any unauthorized field repairs voids warranty and hazardous location ratings. Contact Liberty Pumps at 1-800-543-2550 to locate the closest repair facility
- [2] - WARNING! These motors are listed for application in Class 1, Division 1, Groups C D, EXPLOSION PROOF environments. The pump must be serviced at the factory or a qualified hazardous motor enclosure repair facility approved by Liberty Pumps. Any unauthorized field repairs voids warranty and hazardous location ratings. Contact Liberty Pumps at 1-800-543-2550 to locate the closest repair facility.
- [3] - Part requires factory authorized service. Contact Liberty Pumps at 1-800-543-2550

WARNING! These motors are listed for application in Class 1, Division 1, Groups C D, EXPLOSION PROOF environments. The pump must be serviced at the factory or a qualified hazardous motor enclosure repair facility approved by Liberty Pumps. Any unauthorized field repairs voids warranty and hazardous location ratings. Contact Liberty Pumps at 1-800-543-2550 to locate the closest repair facility

XLE74BM-3 (B90)

XLE74BM-3 (B90)

PAGE

XLE74BM-3 (B90)

- [4] - Acceptable for use in all liberty Pump's oil-filled products
- Acceptable for use in all liberty Pump's oil-filled products