

HT453 (B59)

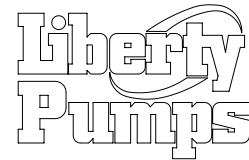
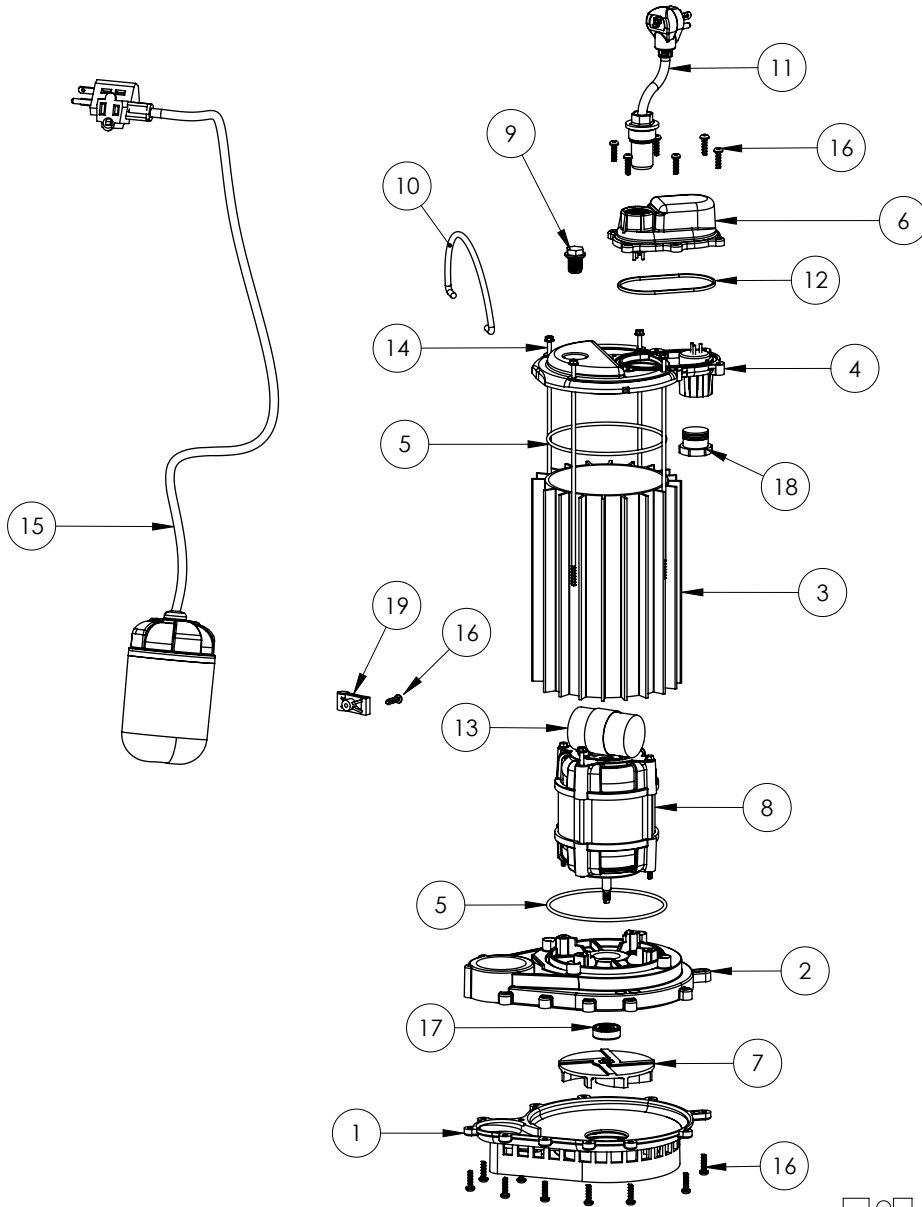

HT453**HT453 (B59)**

#	PART #	DESCRIPTION	QTY	Note
1	233600B	BASE WITH VOLUTE ASSEMBLY	1	
2	23310BB	MOTOR SUPPORT PLATE	1	[1]
3	23070AS	MOTOR HOUSING	1	[1]
4	24060AB	MOTOR COVER	1	[1]
5	2357000	O-RING	2	[1]
6	24070AB	CHAMBER COVER	1	[1]
7	K001168	IMPELLER	1	
8	2417200	MOTOR, 2 POLE PSC 50MM	1	[1]
9	8089000	OIL PLUG, O-RING ASSEMBLY	1	
10	K001082	HANDLE	1	
11	K001060	POWER CORD, 115V, 10FT	1	
12	K001046	SEALRING, CHAMBER COVER	1	
13	2451000	CAPACITOR	1	[1]
14	8147000	#10 x 8.4" STAINLESS STEEL SCREW	4	
15	K001325	PUMP SWITCH, HIGH TEMP 115V 10ft	1	
16	8104200	#10 HILO X 5/8" STAINLESS STEEL SCREW	19	
17	K001254	3043000 5/16" SHAFT SEAL	1	[1]
18	8105000	PROTECTIVE CAP	1	
19	2319000	CLAMP, SWITCH CORD	1	
20	LPOILT1032OZ	REPLACEMENT T10 OIL, QUART BOTTLE (REF 8504000)	1	[2]

PART NOTES:

- [1] - Part requires factory authorized service. Contact Liberty Pumps at 1-800-543-2550
- [2] - Acceptable for use in all liberty Pump's oil-filled products

Acceptable for use in all liberty Pump's oil-filled products