

BALDOR® • RELIANCE 

Product Information Packet

M3536

.33HP,855RPM,3PH,60HZ,56,3514M,TEFC,F1,N

Part Detail							
Revision:	Q	Status:	PRD/A	Change #:		Proprietary:	No
Type:	AC	Elec. Spec:	35WGM499	CD Diagram:	CD0005	Mfg Plant:	
Mech. Spec:	35A011	Layout:	35LYA011	Poles:	08	Created Date:	12-07-2010
Base:	RG	Eff. Date:	03-06-2018	Leads:	9#18		Y

Specs			
Catalog Number:	M3536	Insulation Class:	B
Enclosure:	TEFC	Inverter Code:	Not Inverter
Frame:	56	KVA Code:	L
Frame Material:	Steel	Lifting Lugs:	No Lifting Lugs
Output @ Frequency:	.330 HP @ 60 HZ	Locked Bearing Indicator:	No Locked Bearing
Synchronous Speed @ Frequency:	900 RPM @ 60 HZ	Motor Lead Quantity/Wire Size:	9 @ 18 AWG
Voltage @ Frequency:	208.0 V @ 60 HZ	Motor Lead Exit:	Ko Box
	230.0 V @ 60 HZ	Motor Lead Termination:	Flying Leads
	460.0 V @ 60 HZ	Motor Type:	3514M
XP Class and Group:	None	Mounting Arrangement:	F1
XP Division:	Not Applicable	Power Factor:	51
Agency Approvals:	UR	Product Family:	General Purpose
	CSA	Pulley End Bearing Type:	Ball
Auxillary Box:	No Auxillary Box	Pulley Face Code:	Standard
Auxillary Box Lead Termination:	None	Pulley Shaft Indicator:	Standard
Base Indicator:	Rigid	Rodent Screen:	None
Bearing Grease Type:	Polyrex EM (-20F +300F)	RoHS Status:	ROHS COMPLIANT
Blower:	None	Shaft Extension Location:	Pulley End

Current @ Voltage:	1.000 A @ 460.0 V	Shaft Ground Indicator:	No Shaft Grounding
	1.800 A @ 208.0 V	Shaft Rotation:	Reversible
	2.000 A @ 230.0 V	Shaft Slinger Indicator:	No Slinger
Design Code:	B	Speed Code:	Single Speed
Drip Cover:	No Drip Cover	Motor Standards:	NEMA
Duty Rating:	CONT	Starting Method:	Direct on line
Electrically Isolated Bearing:	Not Electrically Isolated	Thermal Device - Bearing:	NONE (OLD)
Feedback Device:	NO FEEDBACK	Thermal Device - Winding:	None
Front Face Code:	Standard	Vibration Sensor Indicator:	No Vibration Sensor
Front Shaft Indicator:	None	Winding Thermal 1:	None
Heater Indicator:	No Heater	Winding Thermal 2:	None

Nameplate NP1256L										
CAT.NO.	M3536									
SPEC.	35A011M499G1									
HP	.33									
VOLTS	208-230/460									
AMP	1.8-2/1									
RPM	855									
FRAME	56				HZ	60			PH	3
SER.F.	1.35			CODE	L	DES	B		CLASS	B
NEMA-NOM-EFF	59.5			PF	51					
RATING	40C AMB-CONT									
CC	USABLE AT 208V									
DE	6205				ODE	6203				
ENCL	TEFC			SN						
	SFA 2.1-2.2/1.1									

Parts List		
Part Number	Description	Quantity
SA212654	SA 35A011M499G1	1.000 EA
RA199884	RA 35A011M499G1	1.000 EA
35FN3002A05SP	EXFN, PLASTIC, 6.376 OD, .638 ID	1.000 EA
NS2512A01	INSULATOR, CONDUIT BOX X	1.000 EA
35CB3007	35 CB CASTING W/.88 DIA. LEAD HOLE	1.000 EA
36GS1000SP	GASKET-CONDUIT BOX, .06 THICK #SV-330 LE	1.000 EA
51XB1016A07	10-16 X 7/16 HXWSSLD SERTYB	2.000 EA
11XW1032G06	10-32 X .38, TAPTITE II, HEX WSHR SLTD U	1.000 EA
35EP3122K00	MASTER ODE,203 BRG,.683SH,#26 DRN,FH MTG	1.000 EA
HW5100A03	WAVY WASHER (W1543-017)	1.000 EA
35EP3123A00	MASTER DE,205 BRG,.998SH,#26 DRN	1.000 EA
XY1032A02	10-32 HEX NUT DIRECTIONAL SERRATION	4.000 EA
51XB1214A16	12-14X1.00 HXWSSLD SERTYB	1.000 EA
35FH4005A32SP	IEC FH NO GRSR W/3 HOLES - PRIMED	1.000 EA
51XW1032A06	10-32 X .38, TAPTITE II, HEX WSHR SLTD S	3.000 EA
35CB4521GX	CONDUIT BOX LID KIT **ORDER INDIV PARTS	1.000 EA
51XW0832A07	8-32 X .44, TAPTITE II, HEX WSHR SLTD SE	4.000 EA
HW2501D13	KEY, 3/16 SQ X 1.375	1.000 EA
HA7000A04	KEY RETAINER 0.625 DIA SHAFTS	1.000 EA
85XU0407S04	4X1/4 U DRIVE PIN STAINLESS	2.000 EA
MJ1000A02	GREASE, POLYREX EM EXXON (USe 4824-15A)	0.050 LB
MG1000G27	MED CHARCOAL METALLIC GREY 400-0096	0.017 GA
HA3100A15	THRUBOLT 10-32 X 8.375	4.000 EA
LC0005E01	CONN.DIA./WARNING LABEL (LC0005/LB1119N)	1.000 EA

Parts List (continued)		
Part Number	Description	Quantity
NP1256L	ALUM UL CSA CC INDUSTRIAL MOTOR A60	1.000 EA
35PA1066	PKG GRP, PRINT PK1008A06	1.000 EA
MN416A01	TAG-INSTAL-MAINT no wire (1200/bx) 5/18	1.000 EA
PE-0000001	ZRTG PE ASSEMBLY	1.000 EA
FE-0000001	ZRTG FE ASSEMBLY	1.000 EA

Accessories		
Part Number	Description	Multiplier
35-8762	C FACE KIT	A8
35EP1506A01SP	D-FLANGE KIT	A8

No performance data has been
assigned to this product.

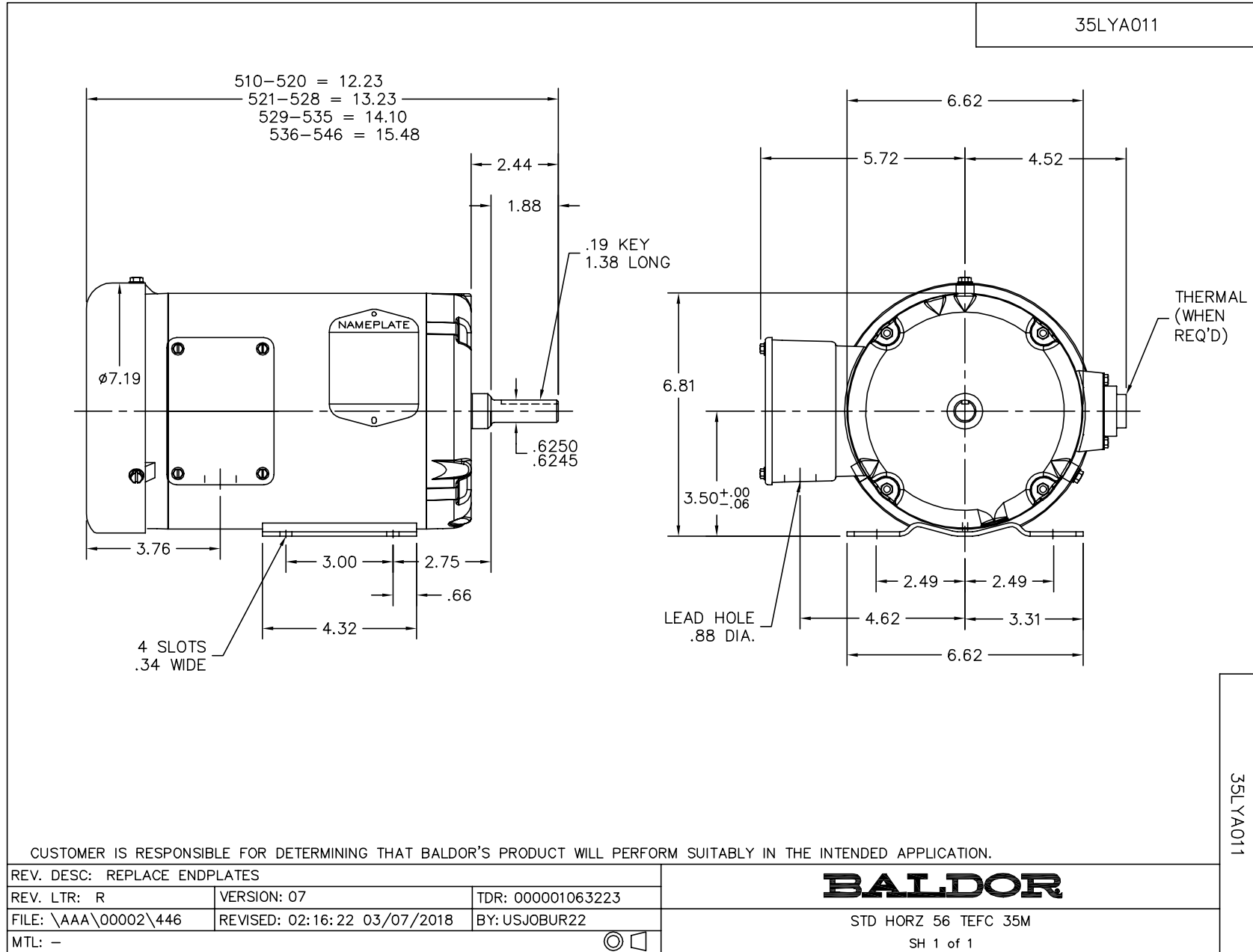

CD0005

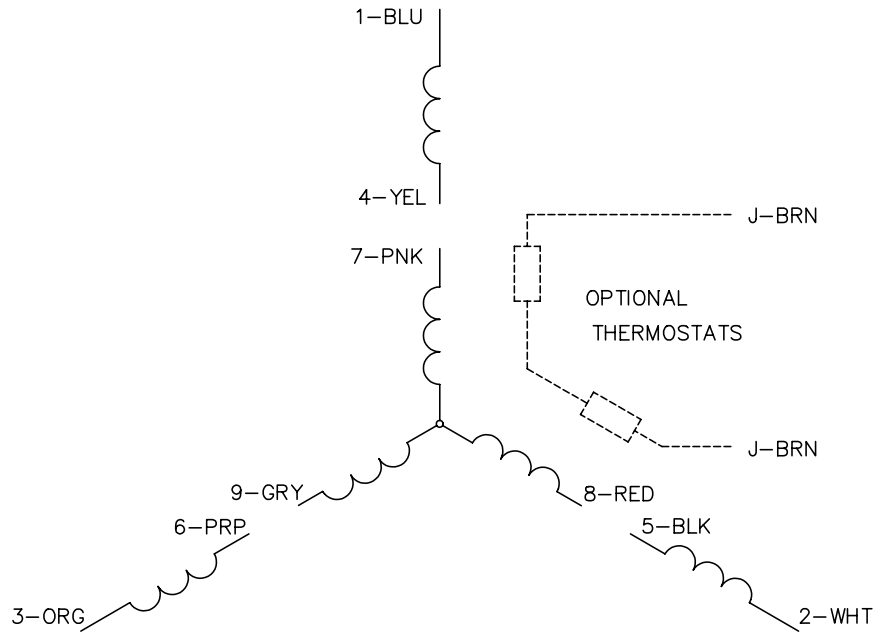

LOW VOLTAGE
(2Y)



LINE

HIGH VOLTAGE
(1Y)



LINE

NOTES:

1. INTERCHANGE ANY TWO LINE LEADS TO REVERSE ROTATION.
2. OPTIONAL THERMOSTATS ARE PROVIDED WHEN SPECIFIED.
3. ACTUAL NUMBER OF INTERNAL PARALLEL CIRCUITS MAY BE A MULTIPLE OF THOSE SHOWN ABOVE.
4. LEAD COLORS ARE OPTIONAL. LEADS MUST ALWAYS BE NUMBERED AS SHOWN.

REV. DESC: REVISE TO SHOW OPTIONAL COLORS

REV. LTR: E BY: JLP

REVISED: 01/19/99 10:15

TDR: 0171435

90000

FILE: AAA00005140

MDL: -

MTL: -

BALDOR ELECTRIC Co.

3PH, DV, 9 LEADS

CD0005