

BALDOR® • RELIANCE 

Product Information Packet

VEJMM3158T

3HP,3450RPM,3PH,60HZ,145JM,3528M,OPEN,F1

Part Detail							
Revision:	S	Status:	PRD/A	Change #:		Proprietary:	No
Type:	AC	Elec. Spec:	35WGL051	CD Diagram:	CD0005	Mfg Plant:	
Mech. Spec:	35E4124	Layout:	35LYE4124	Poles:	02	Created Date:	06-02-2015
Base:	N	Eff. Date:	06-12-2018	Leads:	9#18		

Specs			
Catalog Number:	VEJMM3158T	Insulation Class:	F
Enclosure:	OPEN	Inverter Code:	Inverter Ready
Frame:	145JM	KVA Code:	K
Frame Material:	Steel	Lifting Lugs:	No Lifting Lugs
Output @ Frequency:	3.000 HP @ 60 HZ	Locked Bearing Indicator:	Locked Bearing
Synchronous Speed @ Frequency:	3600 RPM @ 60 HZ	Motor Lead Quantity/Wire Size:	9 @ 18 AWG
Voltage @ Frequency:	460.0 V @ 60 HZ	Motor Lead Exit:	Ko Box
	230.0 V @ 60 HZ	Motor Lead Termination:	Flying Leads
XP Class and Group:	None	Motor Type:	3528M
XP Division:	Not Applicable	Mounting Arrangement:	F1
Agency Approvals:	UR	Power Factor:	89
	CSA EEV	Product Family:	General Purpose
	CSA	Pulley End Bearing Type:	Ball
Auxillary Box:	No Auxillary Box	Pulley Face Code:	C-Face
Auxillary Box Lead Termination:	None	Pulley Shaft Indicator:	Tapped & Key
Base Indicator:	No Mounting	Rodent Screen:	Included
Bearing Grease Type:	Polyrex EM (-20F +300F)	RoHS Status:	ROHS COMPLIANT
Blower:	None	Shaft Extension Location:	Pulley End

Current @ Voltage:	3.800 A @ 460.0 V	Shaft Ground Indicator:	No Shaft Grounding
	7.600 A @ 230.0 V	Shaft Rotation:	Reversible
	8.000 A @ 208.0 V	Shaft Slinger Indicator:	Shaft Slinger
Design Code:	B	Speed Code:	Single Speed
Drip Cover:	Drip Cover	Motor Standards:	NEMA
Duty Rating:	CONT	Starting Method:	Direct on line
Electrically Isolated Bearing:	Not Electrically Isolated	Thermal Device - Bearing:	None
Feedback Device:	NO FEEDBACK	Thermal Device - Winding:	None
Front Face Code:	Standard	Vibration Sensor Indicator:	No Vibration Sensor
Front Shaft Indicator:	None	Winding Thermal 1:	None
Heater Indicator:	No Heater	Winding Thermal 2:	None

Nameplate NP1259L										
CAT.NO.	VEJMM3158T									
SPEC.	35E4124L051G1									
HP	3									
VOLTS	230/460									
AMP	7.6/3.8									
RPM	3450									
FRAME	145JM				HZ	60			PH	3
SER.F.	1.15		CODE	K	DES	B		CL	F	
NEMA-NOM-EFF	85.5		PF	89						
RATING	40C AMB-CONT									
CC	010A				USABLE AT 208V			8		
DE	6206				ODE	6203				
ENCL	OPEN		SN							

Parts List		
Part Number	Description	Quantity
SA303583	SA 35E4124L051G1	1.000 EA
RA290714	RA 35E4124L051G1	1.000 EA
NS2512A01	INSULATOR, CONDUIT BOX X	1.000 EA
35CB3007	35 CB CASTING W/.88 DIA. LEAD HOLE	1.000 EA
51XB1016A07	10-16 X 7/16 HXWSSLD SERTYB	2.000 EA
11XW1032G06	10-32X3/8 HX WSHR HD,SLTDTYPE 23,GREEN	1.000 EA
35EP3209F01	F00 W/GRSR	1.000 EA
HW4500A01	1641B(ALEMITE)400 UNIV, GREASE FITT	1.000 EA
HW5100A03	WAVY WASHER (W1543-017)	1.000 EA
HA1100A03	SCREEN, RODENT	1.000 EA
51XT1032A04	10-32X1/4 HX WA SL SR TYT (F/S)	3.000 EA
HW1000A10	#10 FLAT WASHER (SAE)	3.000 EA
35EP3401A05	B/OPEN FACE MTD. ENDPLATE 35 FRAME 206 B	1.000 EA
35AD2001	AIR BAFFLE	1.000 EA
15XF0632A06	6-32 X 3/8 PHILL PAN HD TYPE F	4.000 EA
HW4500A01	1641B(ALEMITE)400 UNIV, GREASE FITT	1.000 EA
51XN1032A16	10-32 X 1.000 HX WS SL SR	2.000 EA
35FH4006A04	DRIP COVER SPECIAL, W/ PRIMER	1.000 EA
51XW1032A06	10-32 X .38, TAPTITE II, HEX WSHR SLTD S	3.000 EA
HA1102A08	RODENT SCREEN 35 OPEN FACE MTD	1.000 EA
51XT1032A04	10-32X1/4 HX WA SL SR TYT (F/S)	4.000 EA
HW1000A10	#10 FLAT WASHER (SAE)	4.000 EA
35CB4521	35 LIPPED CB LID (GALV & PHOSPH)	1.000 EA
51XW0832A07	8-32 X .44, TAPTITE II, HEX WSHR SLTD SE	4.000 EA

Parts List (continued)		
Part Number	Description	Quantity
HW4600B36SP	V-RING SLINGER 1.188 X 1.690 X .24 VITON	2.000 EA
HW2501D13	KEY, 3/16 SQ X 1.375	1.000 EA
HA7000A01	KEY RETAINER 7/8" DIA SHAFT	1.000 EA
85XU0407S04	4X1/4 U DRIVE PIN STAINLESS	2.000 EA
MJ1000A02	GREASE, POLYREX EM EXXON (USe 4824-15A)	0.050 LB
MG1000Y03	MUNSELL 2.53Y 6.70/ 4.60, GLOSS 20,	0.017 GA
HA3100A15	THRUBOLT 10-32 X 8.375	4.000 EA
LB1119N	WARNING LABEL	1.000 EA
MN416A01	TAG-INSTAL-MAINT no wire (1200/bx) 5/18	1.000 EA
LC0005	CONN.DIA.,TY M,9-LD,DUAL VOLT,REVERSING	1.000 EA
NP1259L	ALUM SUPER-E UL CSA-EEV CC NEMA PREMIUM	1.000 EA
36PA1000	PKG GRP, PRINT PK1016A06	1.000 EA
PK3083T	STYROFOAM PACKING CRADLE	1.000 EA
PK3088	MICROFOAM, 8"X"8 PERF. SHEETS 5,400/RL	1.000 EA

AC Induction Motor Performance Data

Record # 48297 - Typical performance - not guaranteed values

Winding: 35WGL051-R004	Type: 3528M	Enclosure: ODP
-------------------------------	--------------------	-----------------------

Nameplate Data				460 V, 60 Hz: High Voltage Connection	
Rated Output (HP)	3			Full Load Torque	4.65 LB-FT
Volts	230/460			Start Configuration	direct on line
Full Load Amps	7.6/3.8			Breakdown Torque	18.7 LB-FT
R.P.M.	3450			Pull-up Torque	12.2 LB-FT
Hz	60	Phase	3	Locked-rotor Torque	17.3 LB-FT
NEMA Design Code	B	KVA Code	K	Starting Current	32 A
Service Factor (S.F.)	1.15			No-load Current	1.36 A
NEMA Nom. Eff.	85.5	Power Factor	89	Line-line Res. @ 25°C	4.7021 Ω
Rating - Duty	40C AMB-CONT			Temp. Rise @ Rated Load	

Load Characteristics 460 V, 60 Hz, 3 HP

% of Rated Load	25	50	75	100	125	150	S.F.
Power Factor	55	76	85	89	92	93	91
Efficiency	82.1	87	87.4	86.2	84.6	82.2	85.2
Speed	3566.3	3535	3499.4	3457.2	3415.1	3364.7	3432
Line amperes	1.63	2.16	2.88	3.74	4.57	5.58	4.24

Performance Graph at 460V, 60Hz, 3.0HP Typical performance - Not guaranteed values

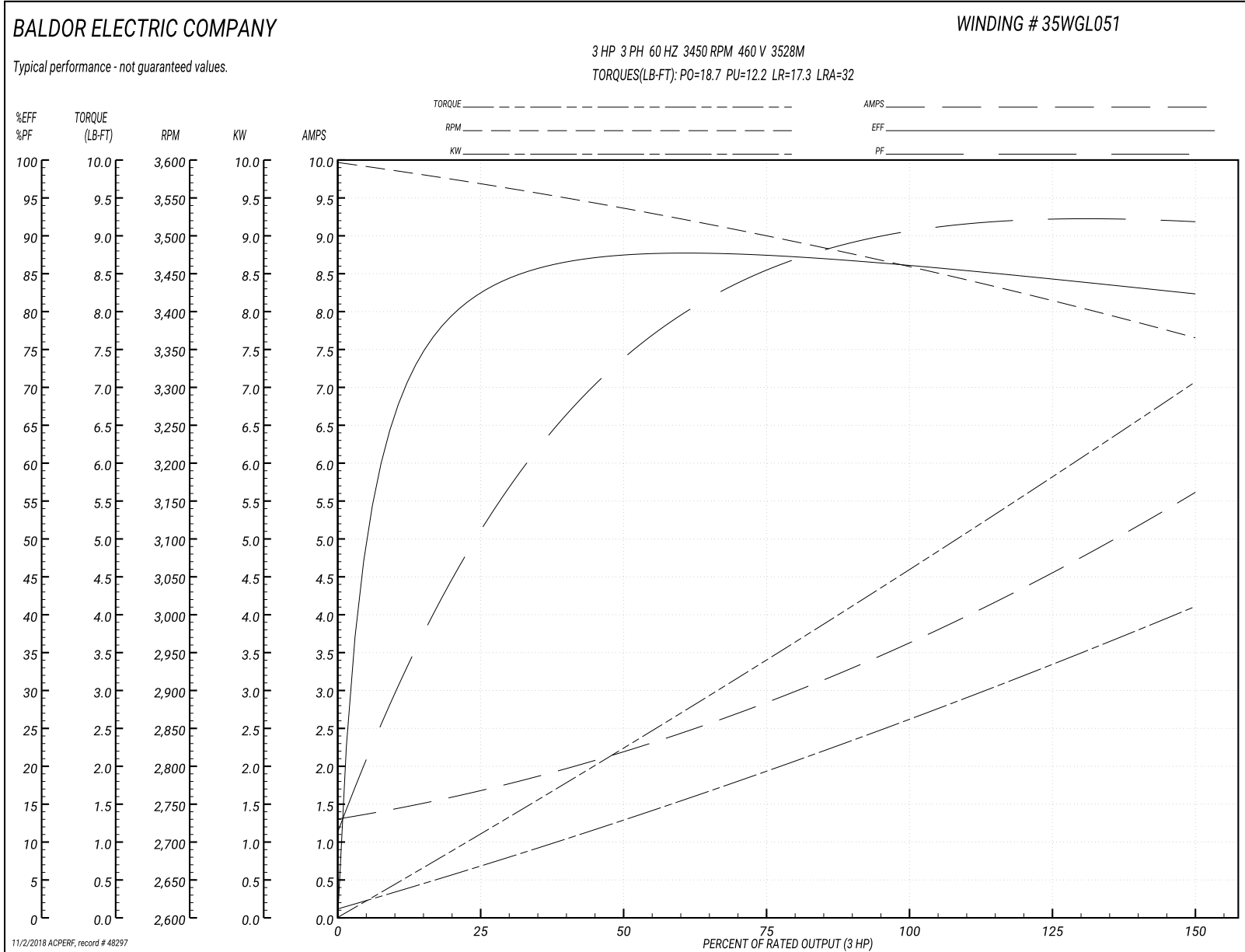

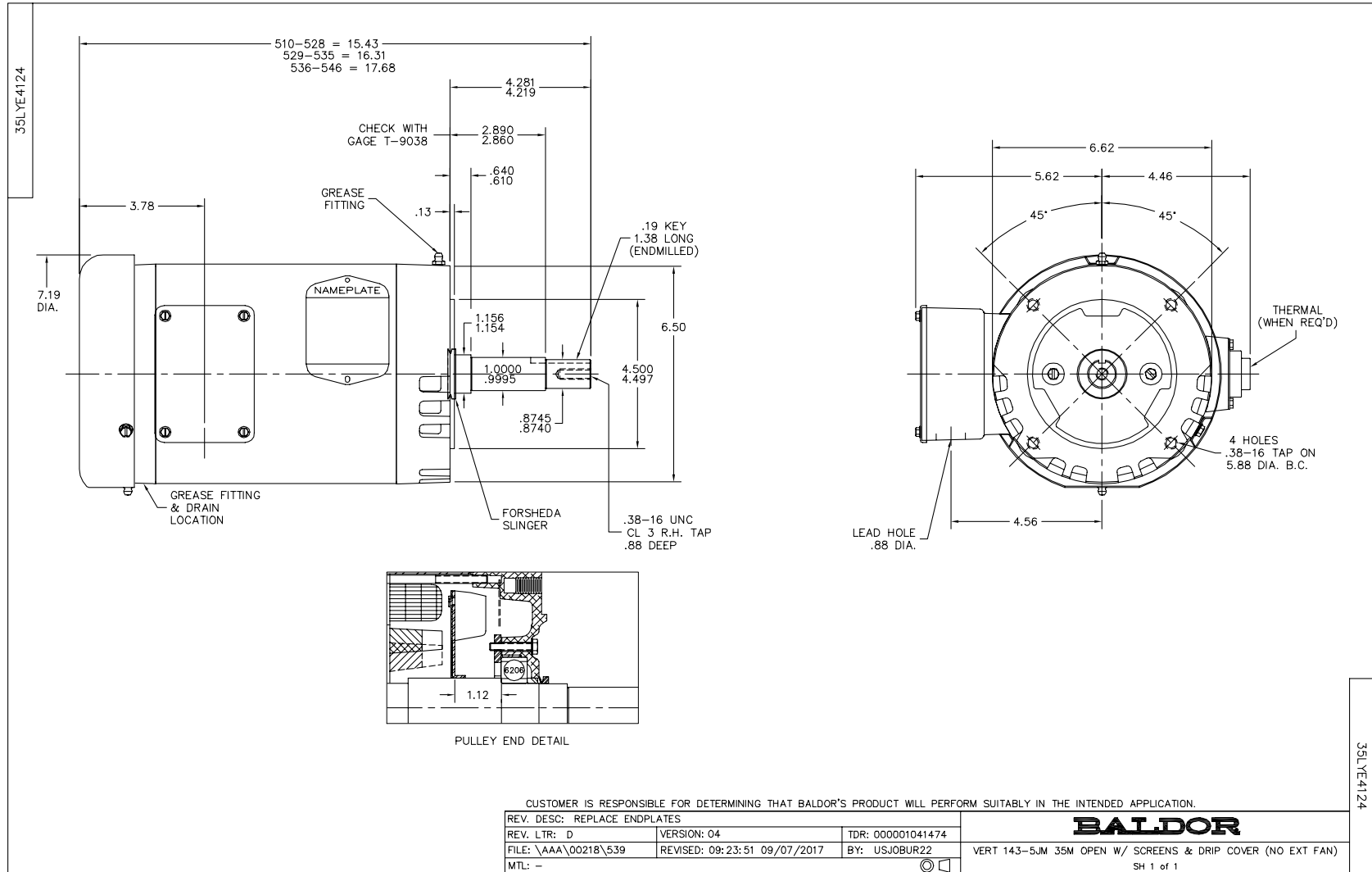

CD0005



LOW VOLTAGE
(2Y)



LINE

HIGH VOLTAGE
(1Y)

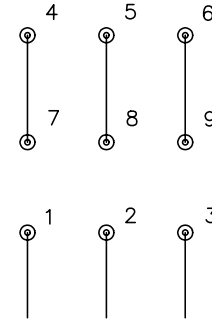

LINE

NOTES:

1. INTERCHANGE ANY TWO LINE LEADS TO REVERSE ROTATION.
2. OPTIONAL THERMOSTATS ARE PROVIDED WHEN SPECIFIED.
3. ACTUAL NUMBER OF INTERNAL PARALLEL CIRCUITS MAY BE A MULTIPLE OF THOSE SHOWN ABOVE.
4. LEAD COLORS ARE OPTIONAL. LEADS MUST ALWAYS BE NUMBERED AS SHOWN.

REV. DESC: REVISE TO SHOW OPTIONAL COLORS

REV. LTR: E BY: JLP

REVISED: 01/19/99 10:15

TDR: 0171435

90000

FILE: AAA00005140

MDL: -

MTL: -

BALDOR ELECTRIC Co.

3PH, DV, 9 LEADS

CD0005