

BALDOR® • RELIANCE 

Product Information Packet

VEM7014

1//.75HP,1760//1460RPM,3PH,60//50HZ,56C

Part Detail							
Revision:	D	Status:	PRD/A	Change #:		Proprietary:	No
Type:	AC	Elec. Spec:	35WGM492	CD Diagram:	CD0005	Mfg Plant:	
Mech. Spec:	35E374	Layout:	35LYE374	Poles:	04	Created Date:	09-01-2015
Base:	N	Eff. Date:	07-13-2017	Leads:	9#18		

Specs			
Catalog Number:	VEM7014	Front Shaft Indicator:	None
Enclosure:	XPFC	Heater Indicator:	No Heater
Frame:	56C	Insulation Class:	B
Frame Material:	Steel	Inverter Code:	Not Inverter
Output @ Frequency:	.750 HP @ 50 HZ	KVA Code:	L
	1.000 HP @ 60 HZ	Lifting Lugs:	No Lifting Lugs
Synchronous Speed @ Frequency:	1500 RPM @ 50 HZ	Locked Bearing Indicator:	Locked Bearing
Voltage @ Frequency:	230.0 V @ 60 HZ	Motor Lead Quantity/Wire Size:	9 @ 18 AWG
	190.0 V @ 50 HZ	Motor Lead Exit:	Ko Box
	460.0 V @ 60 HZ	Motor Lead Termination:	Flying Leads
	380.0 V @ 50 HZ	Motor Type:	3520M
XP Class and Group:	CLI GP D; CLII GP F,G	Mounting Arrangement:	F1
XP Division:	Division I	Power Factor:	71
Agency Approvals:	CSA	Product Family:	Hazardous Location Motor
	CSA EEV	Pulley End Bearing Type:	Ball
	UR	Pulley Face Code:	C-Face
Auxillary Box:	No Auxillary Box	Pulley Shaft Indicator:	Standard
Auxillary Box Lead Termination:	None	Rodent Screen:	None

Base Indicator:	No Mounting	RoHS Status:	ROHS COMPLIANT
Bearing Grease Type:	Polyrex EM (-20F +300F)	Shaft Extension Location:	Pulley End
Blower:	None	Shaft Ground Indicator:	No Shaft Grounding
Current @ Voltage:	3.100 A @ 208.0 V	Shaft Rotation:	Reversible
	3.000 A @ 230.0 V	Shaft Slinger Indicator:	No Slinger
	2.800 A @ 190.0 V	Speed Code:	Single Speed
	1.500 A @ 460.0 V	Motor Standards:	NEMA
	1.400 A @ 380.0 V	Starting Method:	Direct on line
Design Code:	B	Thermal Device - Bearing:	NONE (OLD)
Drip Cover:	No Drip Cover	Thermal Device - Winding:	Normally Closed Thermostat
Duty Rating:	CONT	Vibration Sensor Indicator:	No Vibration Sensor
Electrically Isolated Bearing:	Not Electrically Isolated	Winding Thermal 1:	None
Feedback Device:	NO FEEDBACK	Winding Thermal 2:	None
Front Face Code:	Standard	XP Temp Code:	T3C

Nameplate NP1426XPSLEV	
NO.	<input type="text"/> CC 010A
SER.	<input type="text"/>
SPEC.	35E374M492G3
CAT.NO.	VEM7014
HP	1//.75 T. CODE T3C
VOLTS	230/460//190/380
AMPS	3/1.5//2.8/1.4
RPM	1760//1460
HZ	60//50 PH 3 CL B
SER.F.	1.00 DES B CODE L
RATING	40C AMB-CONT
FRAME	56C NEMA-NOM-EFF 85.5
USABLE AT 208V	3.1 PF 71
BLANK	<input type="text"/>

Parts List		
Part Number	Description	Quantity
SA307212	SA 35E374M492G3	1.000 EA
RA294509	RA 35E374M492G3	1.000 EA
34FN3002B01	EXTERNAL FAN, PLASTIC, .637/.639 HUB W/	1.000 EA
35CB3001A01SP	EXPL CONDUIT BOX, MACH, 1/2" PIPE TAP LE	1.000 EA
11XW1032G06	10-32 X .38, TAPTITE II, HEX WSHR SLTD U	1.000 EA
HW3001B01	BRASS CUP WASHER, FOR #10 SCREW	1.000 EA
35EP3700A01SP	FR ENDPLATE, XPFC	1.000 EA
HW5100A03	WAVY WASHER (W1543-017)	1.000 EA
35EP3702A01SP	PU EP-205 BRG-35X-56C-143-5TC	1.000 EA
51XN1032A20	10-32 X 1 1/4 HX WS SL SR	2.000 EA
XY3118A12	5/16-18 HEX NUT DIRECTIONAL SERRATION	4.000 EA
HA3013A01	1/2-20X5/8 SPL.HX BOLT	2.000 EA
HW3021C06	3/32 DI X .625 PIN (F/S)	2.000 EA
51XB1214A16	12-14X1.00 HXWSSLD SERTYB	1.000 EA
35FH4005A01SP	IEC FH NO GREASER W/PRIMED	1.000 EA
51XW1032A06	10-32 X .38, TAPTITE II, HEX WSHR SLTD S	3.000 EA
35CB3500A01SP	CONDUIT BOX LID, MACH	1.000 EA
51XN2520A16	SCREW, HEX WS SLT, ZN, 1/4-20 X 1.00	4.000 EA
HW2501D13	KEY, 3/16 SQ X 1.375	1.000 EA
HA7000A04	KEY RETAINER 0.625 DIA SHAFTS	1.000 EA
85XU0407S04	4X1/4 U DRIVE PIN STAINLESS	6.000 EA
NP0018F	ALUM UL XP CONDUIT BOX NAMEPLATE	1.000 EA
MJ1000A02	GREASE, POLYREX EM EXXON (USe 4824-15A)	0.050 LB
MG1025G29	WILKOFAS, 789.229, DARK CHARCOAL GRAY	0.017 GA

Parts List (continued)		
Part Number	Description	Quantity
HA3104A06	THRUBOLT 5/16-18 X 8.50 OHIO ROD	4.000 EA
LB1119N	WARNING LABEL	1.000 EA
LC0145B01	CONNECTION LABEL	1.000 EA
NP1426XPSLEV	SS XP UL CSA-EEV CC CL-I GP-D	1.000 EA
36PA1000	PKG GRP, PRINT PK1016A06	1.000 EA
PK3082	STYROFOAM CRADLE	1.000 EA
MN416A01	TAG-INSTAL-MAINT no wire (1200/bx) 5/18	1.000 EA

AC Induction Motor Performance Data

Record # 33669 - Typical performance - not guaranteed values

Winding: 35WGM492-R005	Type: 3520M	Enclosure: XPFC
-------------------------------	--------------------	------------------------

Nameplate Data				460 V, 60 Hz: High Voltage Connection	
Rated Output (HP)	1//.75			Full Load Torque	2.99 LB-FT
Volts	230/460//190/380			Start Configuration	direct on line
Full Load Amps	3/1.5//2.8/1.4			Breakdown Torque	13.5 LB-FT
R.P.M.	1760//1460			Pull-up Torque	8.25 LB-FT
Hz	60//50	Phase	3	Locked-rotor Torque	8.52 LB-FT
NEMA Design Code	B	KVA Code	L	Starting Current	12.4 A
Service Factor (S.F.)	1			No-load Current	1.07 A
NEMA Nom. Eff.	85.5	Power Factor	71	Line-line Res. @ 25°C	15 Ω
Rating - Duty	40C AMB-CONT			Temp. Rise @ Rated Load	36°C
				Locked-rotor Power Factor	53.8
				Rotor inertia	0.118 LB-FT ²

Load Characteristics 460 V, 60 Hz, 1 HP

% of Rated Load	25	50	75	100	125	150
Power Factor	29	46	60	69	75	79
Efficiency	74.2	82.9	85.4	85.8	85.4	84.5
Speed	1790	1781	1771	1760	1749	1736
Line amperes	1.11	1.24	1.39	1.59	1.83	2.11

Performance Graph at 460V, 60Hz, 1.0HP Typical performance - Not guaranteed values

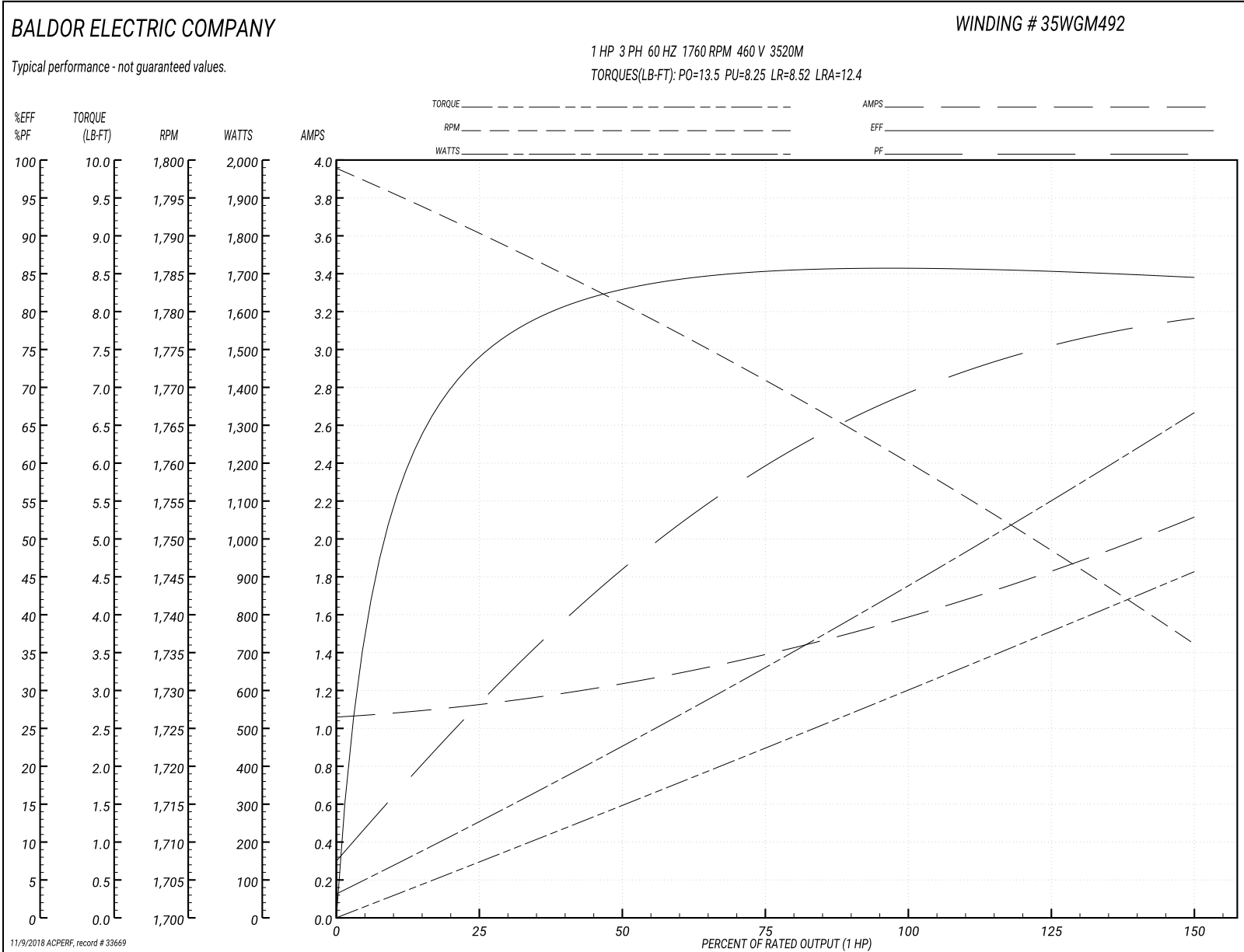

AC Induction Motor Performance Data

Record # 33670 - Typical performance - not guaranteed values

Winding: 35WGM492-R005	Type: 3520M	Enclosure: XPFC
-------------------------------	--------------------	------------------------

Nameplate Data				380 V, 50 Hz: High Voltage Connection	
Rated Output (HP)	1//.75			Full Load Torque	2.7 LB-FT
Volts	230/460//190/380			Start Configuration	direct on line
Full Load Amps	3/1.5//2.8/1.4			Breakdown Torque	12.4 LB-FT
R.P.M.	1760//1460			Pull-up Torque	8.17 LB-FT
Hz	60//50	Phase	3	Locked-rotor Torque	8.44 LB-FT
NEMA Design Code	B	KVA Code	L	Starting Current	11.6 A
Service Factor (S.F.)	1			No-load Current	1.05 A
NEMA Nom. Eff.	85.5	Power Factor	71	Line-line Res. @ 25°C	15 Ω
Rating - Duty	40C AMB-CONT			Temp. Rise @ Rated Load	32°C
				Locked-rotor Power Factor	59.5
				Rotor inertia	0.118 LB-FT ²

Load Characteristics 380 V, 50 Hz, 0.75 HP

% of Rated Load	25	50	75	100	125	150
Power Factor	28	44	58	67	74	79
Efficiency	73.1	81.9	84.4	85	84.5	83.5
Speed	1491	1482	1473	1464	1453	1442
Line amperes	1.08	1.19	1.32	1.49	1.71	1.96

Performance Graph at 380V, 50Hz, 0.75HP Typical performance - Not guaranteed values

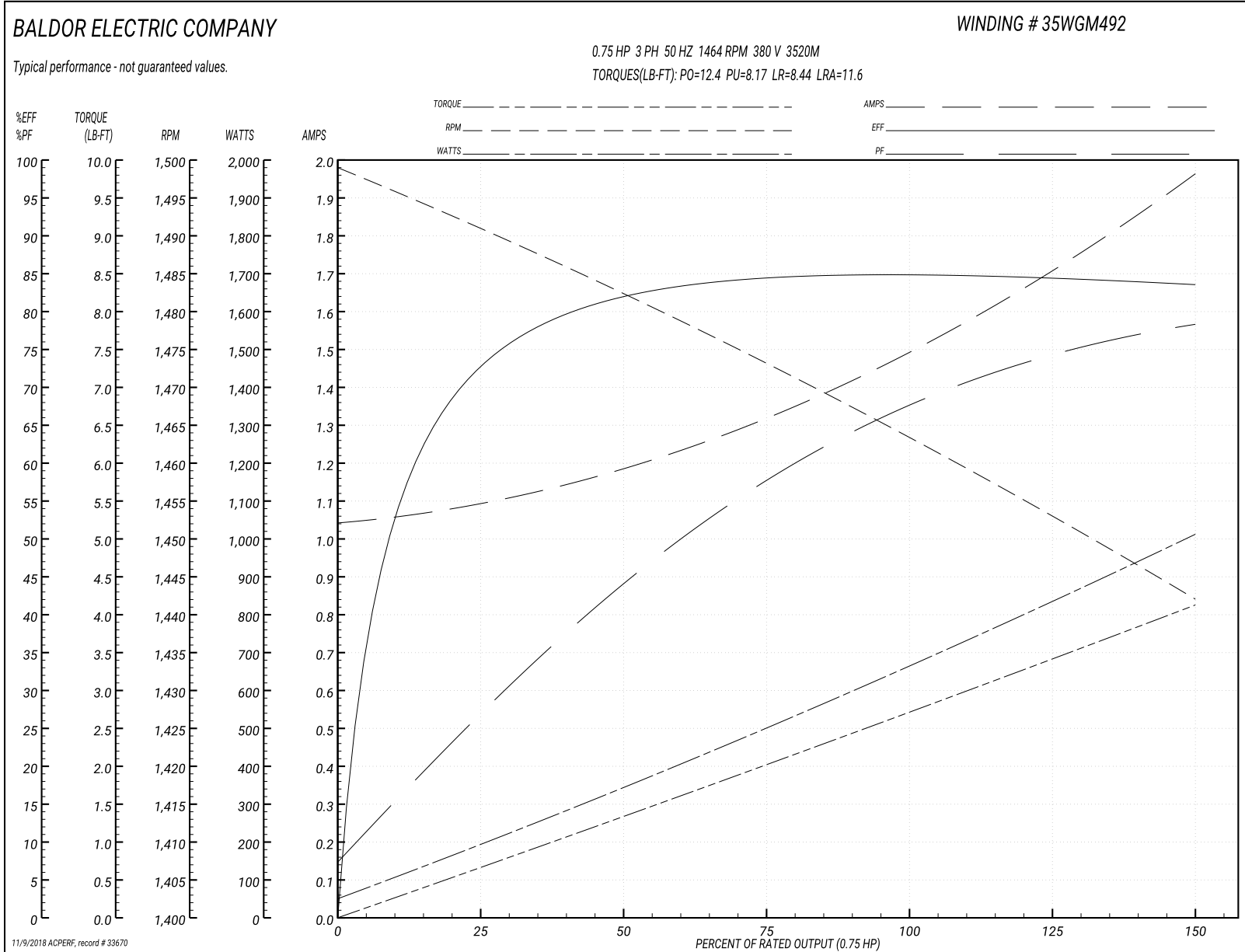

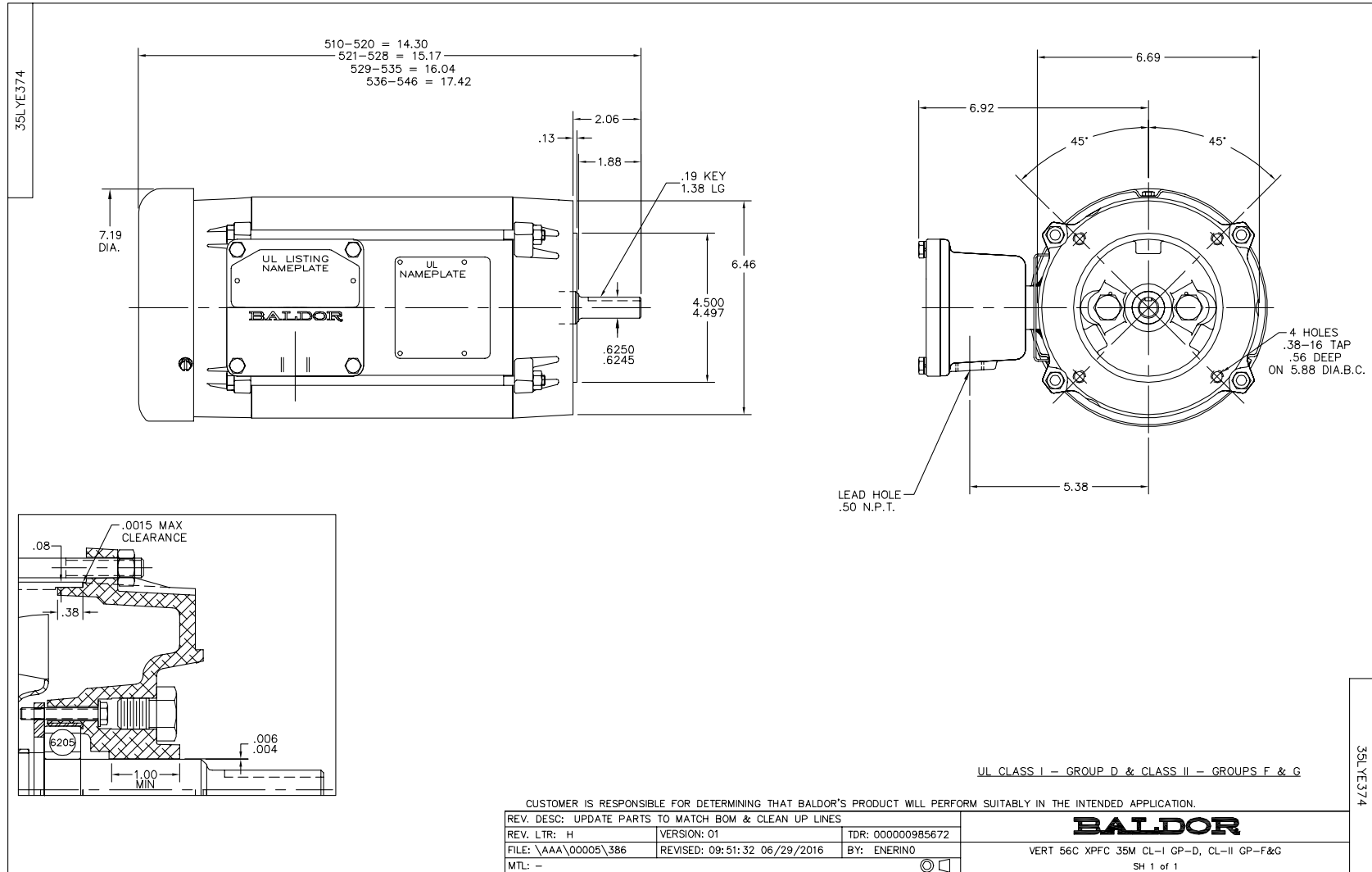

CD0005



LOW VOLTAGE
(2Y)

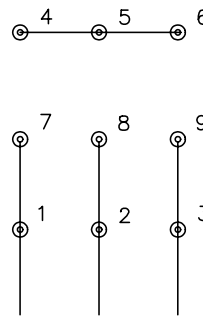

LINE

HIGH VOLTAGE
(1Y)

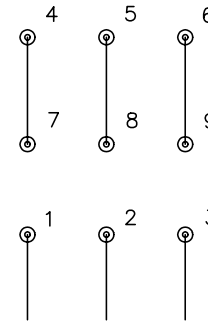

LINE

NOTES:

1. INTERCHANGE ANY TWO LINE LEADS TO REVERSE ROTATION.
2. OPTIONAL THERMOSTATS ARE PROVIDED WHEN SPECIFIED.
3. ACTUAL NUMBER OF INTERNAL PARALLEL CIRCUITS MAY BE A MULTIPLE OF THOSE SHOWN ABOVE.
4. LEAD COLORS ARE OPTIONAL. LEADS MUST ALWAYS BE NUMBERED AS SHOWN.

REV. DESC: REVISE TO SHOW OPTIONAL COLORS			
REV. LTR: E	BY: JLP	REVISED: 01/19/99 10:15	TDR: 0171435
900000		FILE: AAA00005140	MDL: -
		MTL: -	

BALDOR ELECTRIC Co.

3PH, DV, 9 LEADS

CD0005