

BALDOR® • RELIANCE 

Product Information Packet

VFSWDL3504

.5HP, 1740RPM, 1PH, 60HZ, 56C, 3524L, TEFC, F1

Part Detail							
Revision:	A	Status:	PRD/A	Change #:		Proprietary:	No
Type:	AC	Elec. Spec:	35WGN797	CD Diagram:	CD0648	Mfg Plant:	
Mech. Spec:	35E4628	Layout:	35LYE4628	Poles:	04	Created Date:	06-12-2017
Base:	N	Eff. Date:	02-02-2018	Leads:	7#18		

Specs			
Catalog Number:	VFSWDL3504	Inverter Code:	Not Inverter
Enclosure:	TEFC	KVA Code:	M
Frame:	56C	Lifting Lugs:	No Lifting Lugs
Frame Material:	Stainless Steel	Locked Bearing Indicator:	Locked Bearing
Output @ Frequency:	.500 HP @ 60 HZ	Motor Finish:	UNPAINTED
Synchronous Speed @ Frequency:	1800 RPM @ 60 HZ	Motor Lead Quantity/Wire Size:	7 @ 18 AWG
Voltage @ Frequency:	115.0 V @ 60 HZ	Motor Lead Exit:	Ko Box
	230.0 V @ 60 HZ	Motor Lead Termination:	Flying Leads
XP Class and Group:	None	Motor Type:	3524L
XP Division:	Not Applicable	Mounting Arrangement:	F1
Agency Approvals:	UR	Power Factor:	68
	CSA	Product Family:	WD All SD Non-Encapsulated
Auxillary Box:	No Auxillary Box	Pulley End Bearing Type:	Sealed Bearing
Auxillary Box Lead Termination:	None	Pulley Face Code:	C-Face
Base Indicator:	No Mounting	Pulley Shaft Indicator:	Standard
Bearing Grease Type:	Polyrex EM (-20F +300F)	Rodent Screen:	None
Blower:	None	RoHS Status:	ROHS COMPLIANT
Current @ Voltage:	3.500 A @ 230.0 V	Shaft Extension Location:	Pulley End

	7.000 A @ 115.0 V	Shaft Ground Indicator:	No Shaft Grounding
Design Code:	N	Shaft Rotation:	Reversible
Drip Cover:	No Drip Cover	Shaft Slinger Indicator:	No Slinger
Duty Rating:	CONT	Speed Code:	Single Speed
Electrically Isolated Bearing:	Not Electrically Isolated	Motor Standards:	NEMA
Feedback Device:	NO FEEDBACK	Starting Method:	Direct on line
Front Face Code:	Standard	Thermal Device - Bearing:	None
Front Shaft Indicator:	None	Thermal Device - Winding:	None
Heater Indicator:	No Heater	Vibration Sensor Indicator:	No Vibration Sensor
Insulation Class:	F	Winding Thermal 1:	None
		Winding Thermal 2:	None

Nameplate NP1951A13										
CAT.NO.	VFSWDL3504									
SPEC.	35E4628N797G1									
HP	.5									
VOLTS	115/230									
AMP	7/3.5									
RPM	1740									
FRAME	56C				HZ	60			PH	1
SER.F.	1.15		CODE	M	DES	N	CLASS	F		
NEMA-NOM-EFF	70		PF	68						
RATING	40C AMB-CONT									
CC									USABLE AT 208V	
DE	6205				ODE	6205				
ENCL	TEFC		SN							

Parts List		
Part Number	Description	Quantity
SA342506	SA 35E4628N797G1	1.000 EA
RA330933	RA 35E4628N797G1	1.000 EA
EC1400A03SP	ELEC CAP, 400-480 MFD, 125V, 1.81D X 3.	1.000 EA
ES5501	115/25A,L ,CV ,165CO,.8*2.2*1.4,4-7-21	1.000 EA
11XW1032G06	10-32 X .38, TAPTITE II, HEX WSHR SLTD U	1.000 EA
35EP1940A05	FRONT TEFC 205 BRG (STAINLESS)	1.000 EA
RM1070A25	O-RING, VITON/FKM .070CS X 6.190ID	1.000 EA
HW4600G01	.984X1.499X.25 VITON SLICK SERIES LIP	1.000 EA
HW4600E99	25 X 42 X 6 AFX SEAL, GRAPHITE INFUSED V	1.000 EA
HW4500S33	1/8 NPT STAINLESS #304 SS PLUG	3.000 EA
HA4054	SHORT T-DRAIN FITTING, .125" N.P.T.	1.000 EA
HW5100A05	WVY WSHR F/205 & 304 BRGS	1.000 EA
35EP1935A02	PULLEY 56C/143-5TC ENCL 205 BRG	1.000 EA
RM1070A25	O-RING, VITON/FKM .070CS X 6.190ID	1.000 EA
HW4600G01	.984X1.499X.25 VITON SLICK SERIES LIP	1.000 EA
HW4600E99	25 X 42 X 6 AFX SEAL, GRAPHITE INFUSED V	1.000 EA
HW4500S33	1/8 NPT STAINLESS #304 SS PLUG	3.000 EA
HA4054	SHORT T-DRAIN FITTING, .125" N.P.T.	1.000 EA
RM1070A26	O-RING,4.5MM I.D.X1.5MM C.S. (VITON)	4.000 EA
35FH4005A39	IEC FH NO GREASER DEBURR/CLEAN - SS	1.000 EA
10XN1032FS06	HEX HD CAP SCREW 10-32 X 3/8 SS FOOD SAF	3.000 EA
35CB1510A01G	35 CB LID SINGLE PHASE MACHINED W/ FIGP	1.000 EA
10XN1032FS08	HEX HD CAP SCREW 10-32 X 1/2 SS FOOD SAF	6.000 EA
HW2502D13	SS KEY, 3/16 SQ X 1.375	1.000 EA

Parts List (continued)		
Part Number	Description	Quantity
HA7000A04	KEY RETAINER 0.625 DIA SHAFTS	1.000 EA
MJ5001A27	32220KN GRAY SEALER *MIN BUY 4 QTS=1GAL	0.005 QT
MJ5004A93	FOOD GRADE (H1 RATED) ANTISEIZE THRD COM	0.005 EA
WD1000A15	3-520132-2 AMP FLAG (4M/RL NON-CANC/NON-	2.000 EA
MJ1000A02	GREASE, POLYREX EM EXXON (USe 4824-15A)	0.050 LB
WD5603A02	KIT, CLOSED-END LEAD SPLICE (18-14GA)	1.000 EA
HA7724	CAPACITOR CLAMP & SWITCH BRACKET FOR 35C	1.000 EA
51XW0832A07	8-32 X .44, TAPTITE II, HEX WSHR SLTD SE	2.000 EA
51XN1032A08	10-32 X 0.500 HX WS SL SR ZN	1.000 EA
35FN3002A05SP	EXFN, PLASTIC, 6.376 OD, .638 ID	1.000 EA
11XB1214S16	12-14X1.00 HXWSSLD TYP B STAINLESS	1.000 EA
HA3100FS25	THRUBOLT, 10-32 X 9.500 SS FOOD SAFE	4.000 EA
36PA1000	PKG GRP, PRINT PK1016A06	1.000 EA
PK3082	STYROFOAM CRADLE	1.000 EA
MN416A01	TAG-INSTAL-MAINT no wire (1200/bx) 5/18	1.000 EA
HA5027A07	85XU1208S08 FACE DRAIN PINS BAGGED	1.000 EA
FE-0000002	ZRTG FE ASSEMBLY	1.000 EA
PE-0000002	ZRTG PE ASSEMBLY	1.000 EA

No performance data has been
assigned to this product.

35LYE4628

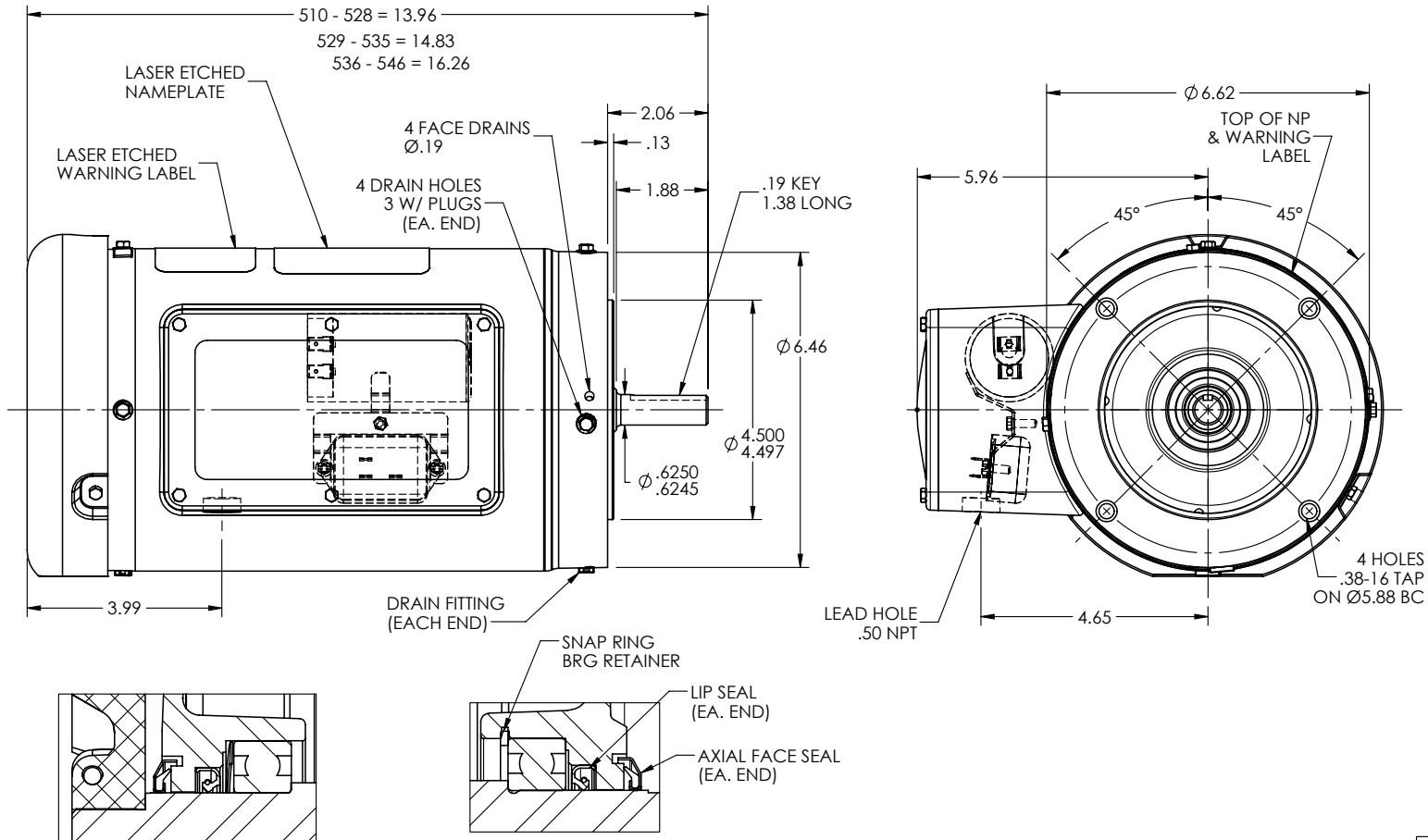

FRONT END DETAIL

PULLEY END DETAIL

CUSTOMER IS RESPONSIBLE FOR DETERMINING THAT BALDOR'S PRODUCT WILL PERFORM SUITABLY IN THE INTENDED APPLICATION

REV. DESC: NEW			
REV: -	VERSION: 00	REVISED: 02:29:23 06/08/2017	TDR: 000001000877
35LYE4628	MODEL NO. 35LYE4628		REF: -
	BY: ENADAF0		

BALDOR

STD VER 56C TEFC 35L WD11/12

35LYE4628

CD0648

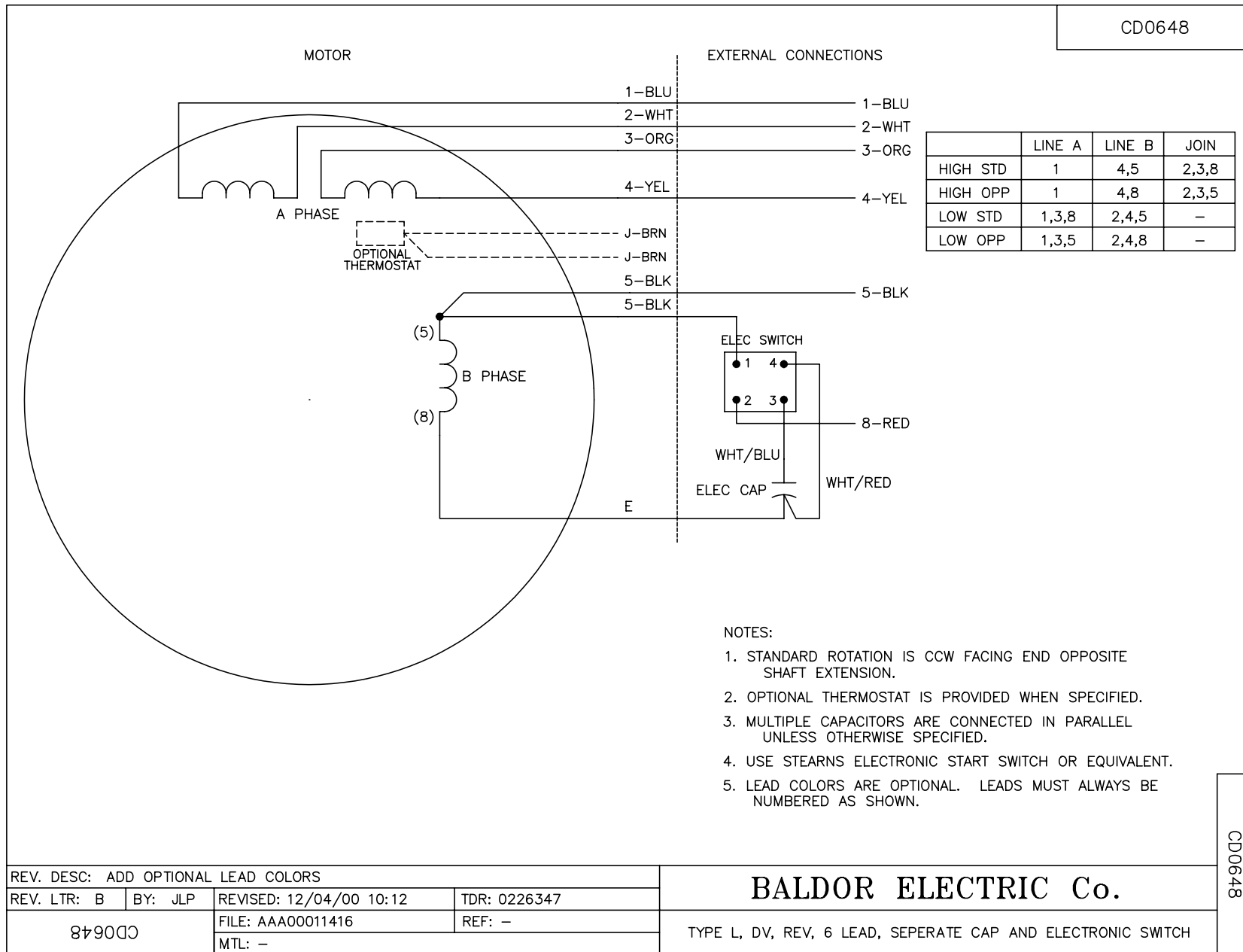

REV. DESC: ADD OPTIONAL LEAD COLORS			
REV. LTR: B	BY: JLP	REVISED: 12/04/00 10:12	TDR: 0226347
879000		FILE: AAA00011416	REF: -
		MTL: -	

BALDOR ELECTRIC Co.

TYPE L, DV, REV, 6 LEAD, SEPERATE CAP AND ELECTRONIC SWITCH

CD0648