

BALDOR® • RELIANCE 

Product Information Packet

VFSWDM3537-E

.5HP,3500RPM,3PH,60HZ,56C,3516M,TENV,F1

Part Detail							
Revision:	D	Status:	PRD/A	Change #:		Proprietary:	No
Type:	AC	Elec. Spec:	35WGP069	CD Diagram:	CD0005	Mfg Plant:	
Mech. Spec:	35E4656	Layout:	35LYE4656	Poles:	02	Created Date:	06-21-2017
Base:	N	Eff. Date:	06-15-2018	Leads:	9#18 15" lead length,0#0 dbl dip & bake,0#0 phase insulaY		

Specs			
Catalog Number:	VFSWDM3537-E	Inverter Code:	Inverter Ready
Enclosure:	TENV	KVA Code:	N
Frame:	56C	Lifting Lugs:	No Lifting Lugs
Frame Material:	Stainless Steel	Locked Bearing Indicator:	Locked Bearing
Output @ Frequency:	.500 HP @ 60 HZ	Motor Finish:	UNPAINTED
Synchronous Speed @ Frequency:	3600 RPM @ 60 HZ	Motor Lead Quantity/Wire Size:	@ 0 AWG
Voltage @ Frequency:	208.0 V @ 60 HZ		9 @ 18 AWG
	230.0 V @ 60 HZ	Motor Lead Exit:	Ko Box
	460.0 V @ 60 HZ	Motor Lead Termination:	Flying Leads
XP Class and Group:	None	Motor Type:	3516M
XP Division:	Not Applicable	Mounting Arrangement:	F1
Agency Approvals:	UR	Power Factor:	84
	CSA	Product Family:	WD All SS Encapsulated
Auxillary Box:	No Auxillary Box	Pulley End Bearing Type:	Sealed Bearing
Auxillary Box Lead Termination:	None	Pulley Face Code:	C-Face
Base Indicator:	No Mounting	Pulley Shaft Indicator:	Standard
Bearing Grease Type:	Polyrex EM (-20F +300F)	Rodent Screen:	None
Blower:	None	RoHS Status:	ROHS COMPLIANT

Current @ Voltage:	.700 A @ 460.0 V	Shaft Extension Location:	Pulley End
	1.400 A @ 230.0 V	Shaft Ground Indicator:	No Shaft Grounding
	1.500 A @ 208.0 V	Shaft Rotation:	Reversible
Design Code:	B	Shaft Slinger Indicator:	No Slinger
Drip Cover:	No Drip Cover	Speed Code:	Single Speed
Duty Rating:	CONT	Motor Standards:	NEMA
Electrically Isolated Bearing:	Not Electrically Isolated	Starting Method:	Direct on line
Feedback Device:	NO FEEDBACK	Thermal Device - Bearing:	None
Front Face Code:	Standard	Thermal Device - Winding:	None
Front Shaft Indicator:	None	Vibration Sensor Indicator:	No Vibration Sensor
Heater Indicator:	No Heater	Winding Thermal 1:	None
Insulation Class:	H	Winding Thermal 2:	None

Nameplate NP1951A01										
CAT.NO.	VFSWDM3537-E									
SPEC.	35E4656P069G1									
HP	.5									
VOLTS	208-230/460									
AMP	1.5-1.4/.7									
RPM	3500									
FRAME	56C				HZ	60			PH	3
SER.F.	1.15		CODE	N	DES	B		CLASS	H	
NEMA-NOM-EFF	84			PF	84					
RATING	40C AMB-CONT									
CC									USABLE AT 208V	1.5
DE	6205				ODE	6205				
ENCL	TENV		SN							
	4:1CT, 10:1VT									

Parts List		
Part Number	Description	Quantity
SA343170	SA 35E4656P069G1	1.000 EA
RA331615	RA 35E4656P069G1	1.000 EA
RM1070A81	O-RING, -043 VITON/FKM .070CS X 3.489ID	1.000 EA
11XW1032G08	10-32 X .50, TAPTITE II, HEX WSHR SLTD U	1.000 EA
HW3001B02	BRASS CUP WASHER W/GROUND SYMBOL TAB,	1.000 EA
35EP1940A03	FRONT TENV 205 BRG (STAINLESS)	1.000 EA
RM1070A25	O-RING, VITON/FKM .070CS X 6.190ID	1.000 EA
HA4054	SHORT T-DRAIN FITTING, .125" N.P.T.	1.000 EA
HW4500S33	1/8 NPT STAINLESS #304 SS PLUG	3.000 EA
HW5100A05	WVY WSHR F/205 & 304 BRGS	1.000 EA
35EP1935A02	PULLEY 56C/143-5TC ENCL 205 BRG	1.000 EA
RM1070A25	O-RING, VITON/FKM .070CS X 6.190ID	1.000 EA
HW4600G01	.984X1.499X.25 VITON SLICK SERIES LIP	1.000 EA
HW4600E99	25 X 42 X 6 AFX SEAL, GRAPHITE INFUSED V	1.000 EA
HW4500S33	1/8 NPT STAINLESS #304 SS PLUG	3.000 EA
HA4054	SHORT T-DRAIN FITTING, .125" N.P.T.	1.000 EA
RM1070A26	O-RING,4.5MM I.D.X1.5MM C.S. (VITON)	4.000 EA
RM1070A81	O-RING, -043 VITON/FKM .070CS X 3.489ID	1.000 EA
HW2502D13	SS KEY, 3/16 SQ X 1.375	1.000 EA
HA7000A04	KEY RETAINER 0.625 DIA SHAFTS	1.000 EA
MJ5001A27	32220KN GRAY SEALER *MIN BUY 4 QTS=1GAL	0.005 QT
MJ5004A93	FOOD GRADE (H1 RATED) ANTISEIZE THRD COM	0.005 EA
MJ1000A02	GREASE, POLYREX EM EXXON (USe 4824-15A)	0.050 LB
WD5603A01	KIT, CLOSED-END LEAD SPLICE (18-14GA)	1.000 EA

Parts List (continued)		
Part Number	Description	Quantity
HA3100FS11	THRUBOLT, 10-32 X 8.500 SS FOOD SAFE	4.000 EA
36PA1000	PKG GRP, PRINT PK1016A06	1.000 EA
PK3082	STYROFOAM CRADLE	1.000 EA
MN416A01	TAG-INSTAL-MAINT no wire (1200/bx) 5/18	1.000 EA
HA5027A07	85XU1208S08 FACE DRAIN PINS BAGGED	1.000 EA
FE-0000001	ZRTG FE ASSEMBLY	1.000 EA
PE-0000002	ZRTG PE ASSEMBLY	1.000 EA

AC Induction Motor Performance Data

Record # 63631 - Typical performance - not guaranteed values

Winding: 35WGP069-R009	Type: 3516M	Enclosure: TENV
-------------------------------	--------------------	------------------------

Nameplate Data				460 V, 60 Hz: High Voltage Connection	
Rated Output (HP)	.5			Full Load Torque	0.753 LB-FT
Volts	208-230/460			Start Configuration	direct on line
Full Load Amps	1.5-1.4/.7			Breakdown Torque	4.09 LB-FT
R.P.M.	3500			Pull-up Torque	2.2 LB-FT
Hz	60	Phase	3	Locked-rotor Torque	2.47 LB-FT
NEMA Design Code	B	KVA Code	N	Starting Current	6.97 A
Service Factor (S.F.)	1.15			No-load Current	0.394 A
NEMA Nom. Eff.	84	Power Factor	84	Line-line Res. @ 25°C	25.2 Ω
Rating - Duty	40C AMB-CONT			Temp. Rise @ Rated Load	63°C
S.F. Amps				Temp. Rise @ S.F. Load	72°C
				Locked-rotor Power Factor	54.7
				Rotor inertia	0.0443 LB-FT ²

Load Characteristics 460 V, 60 Hz, 0.5 HP

% of Rated Load	25	50	75	100	125	150	S.F.
Power Factor	50	65	74	81	84	87	83
Efficiency	49.5	65	71.2	75	76.3	76.7	75.8
Speed	3568	3541	3517	3492	3464	3436	3475
Line amperes	0.453	0.545	0.65	0.774	0.904	1.05	0.852

Performance Graph at 460V, 60Hz, 0.5HP Typical performance - Not guaranteed values

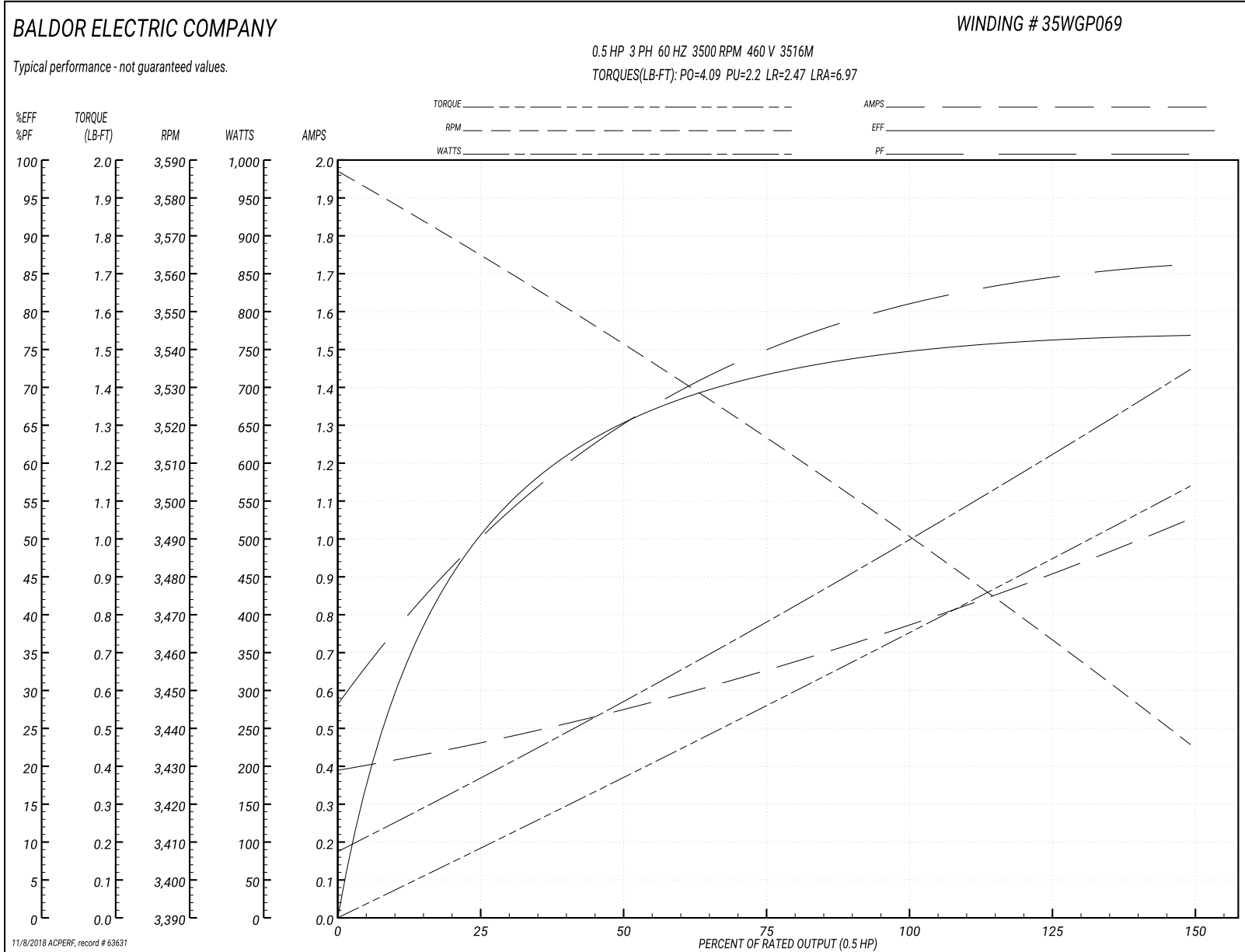

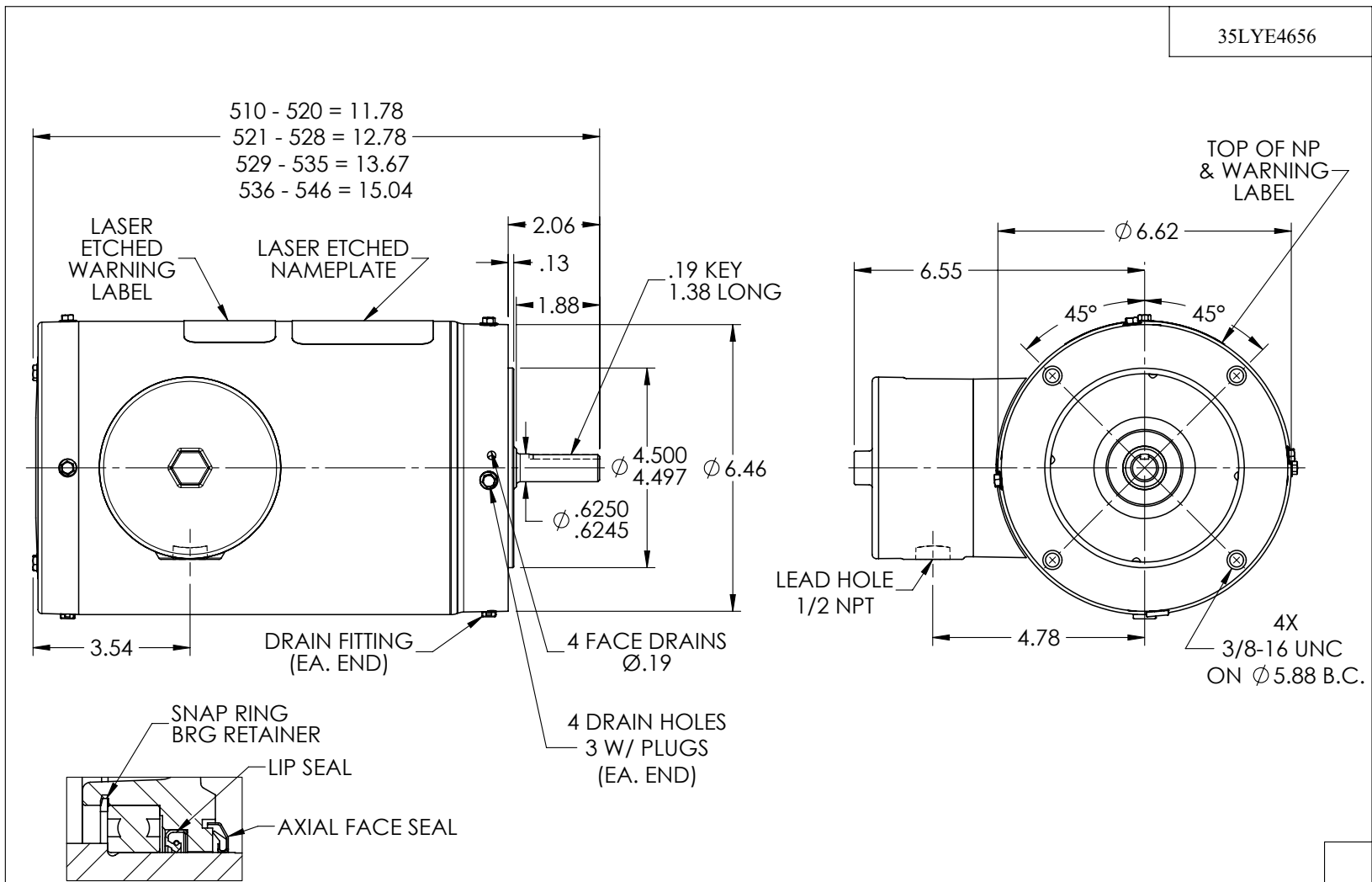

PULLEY END DETAIL

CUSTOMER IS RESPONSIBLE FOR DETERMINING THAT BALDOR'S PRODUCT WILL PERFORM SUITABLY IN THE INTENDED APPLICATION

REV. DESC: UPDATE PULLEY END DETAIL			
REV: A	VERSION: 01	REVISED: 02:27:07 10/16/2017	TDR: 000001028033
35LYE4656		MODEL NO. 35LYE4656	REF: -
		BY: ENANGGO	

BALDOR

STD VER 56C TENV 35M WD11/12

35LYE4656

CD0005

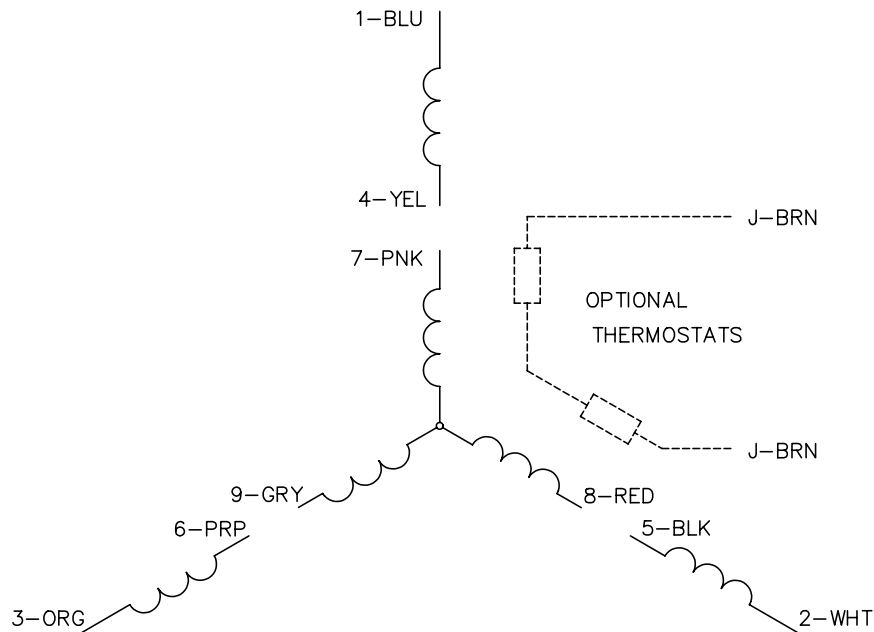

LOW VOLTAGE
(2Y)

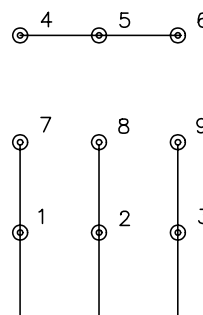

LINE

HIGH VOLTAGE
(1Y)

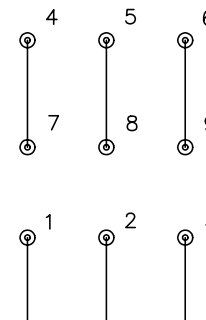

LINE

NOTES:

1. INTERCHANGE ANY TWO LINE LEADS TO REVERSE ROTATION.
2. OPTIONAL THERMOSTATS ARE PROVIDED WHEN SPECIFIED.
3. ACTUAL NUMBER OF INTERNAL PARALLEL CIRCUITS MAY BE A MULTIPLE OF THOSE SHOWN ABOVE.
4. LEAD COLORS ARE OPTIONAL. LEADS MUST ALWAYS BE NUMBERED AS SHOWN.

REV. DESC: REVISE TO SHOW OPTIONAL COLORS			
REV. LTR: E	BY: JLP	REVISED: 01/19/99 10:15	TDR: 0171435
90000		FILE: AAA00005140	MDL: -
		MTL: -	

BALDOR ELECTRIC Co.

3PH, DV, 9 LEADS

CD0005