

BALDOR® • RELIANCE 

Product Information Packet

VFSWDM3554T-E

1.5HP, 1760RPM, 3PH, 60HZ, 145TC, 3528M, TEFC

Part Detail							
Revision:	C	Status:	PRD/A	Change #:		Proprietary:	No
Type:	AC	Elec. Spec:	35WGL770	CD Diagram:	CD0005	Mfg Plant:	
Mech. Spec:	35E4709	Layout:	35LYE4709	Poles:	04	Created Date:	07-11-2017
Base:	N	Eff. Date:	04-11-2018	Leads:	9#18		

Specs			
Catalog Number:	VFSWDM3554T-E	Inverter Code:	Inverter Ready
Enclosure:	TEFC	KVA Code:	L
Frame:	145TC	Lifting Lugs:	No Lifting Lugs
Frame Material:	Stainless Steel	Locked Bearing Indicator:	Locked Bearing
Output @ Frequency:	1.500 HP @ 60 HZ	Motor Finish:	UNPAINTED
Synchronous Speed @ Frequency:	1800 RPM @ 60 HZ	Motor Lead Quantity/Wire Size:	9 @ 18 AWG
Voltage @ Frequency:	460.0 V @ 60 HZ	Motor Lead Exit:	Ko Box
	230.0 V @ 60 HZ	Motor Lead Termination:	Flying Leads
XP Class and Group:	None	Motor Type:	3528M
XP Division:	Not Applicable	Mounting Arrangement:	F1
Agency Approvals:	CSA	Power Factor:	75
	UR	Product Family:	WD All SS Encapsulated
Auxillary Box:	No Auxillary Box	Pulley End Bearing Type:	Sealed Bearing
Auxillary Box Lead Termination:	None	Pulley Face Code:	C-Face
Base Indicator:	No Mounting	Pulley Shaft Indicator:	Standard
Bearing Grease Type:	Polyrex EM (-20F +300F)	Rodent Screen:	None
Blower:	None	RoHS Status:	ROHS COMPLIANT
Current @ Voltage:	2.200 A @ 460.0 V	Shaft Extension Location:	Pulley End

	4.400 A @ 230.0 V	Shaft Ground Indicator:	No Shaft Grounding
	4.500 A @ 208.0 V	Shaft Rotation:	Reversible
Design Code:	B	Shaft Slinger Indicator:	No Slinger
Drip Cover:	No Drip Cover	Speed Code:	Single Speed
Duty Rating:	CONT	Motor Standards:	NEMA
Electrically Isolated Bearing:	Not Electrically Isolated	Starting Method:	Direct on line
Feedback Device:	NO FEEDBACK	Thermal Device - Bearing:	None
Front Face Code:	Standard	Thermal Device - Winding:	None
Front Shaft Indicator:	None	Vibration Sensor Indicator:	No Vibration Sensor
Heater Indicator:	No Heater	Winding Thermal 1:	None
Insulation Class:	H	Winding Thermal 2:	None

Nameplate NP1953A01										
CAT.NO.	VFSWDM3554T-E									
SPEC.	35E4709L770G1									
HP	1.5									
VOLTS	230/460									
AMP	4.4/2.2									
RPM	1760									
FRAME	145TC				HZ	60			PH	3
SER.F.	1.15		CODE	L	DES	B		CLASS	H	
NEMA-NOM-EFF	86.5			PF	75					
RATING	40C AMB-CONT									
CC	010A				USABLE AT 208V	4.5				
DE	6205			ODE	6205					
ENCL	TEFC		SN							
	4:1CT, 10:1VT									

Parts List		
Part Number	Description	Quantity
SA343205	SA 35E4709L770G1	1.000 EA
RA331653	RA 35E4709L770G1	1.000 EA
34FN3002A01SP	EXTERNAL FAN, PLASTIC, .637/.639 HUB W/	1.000 EA
RM1070A81	O-RING, -043 VITON/FKM .070CS X 3.489ID	1.000 EA
11XW1032G08	10-32 X .50, TAPTITE II, HEX WSHR SLTD U	1.000 EA
HW3001B02	BRASS CUP WASHER W/GROUND SYMBOL TAB,	1.000 EA
35EP1940A05	FRONT TEFC 205 BRG (STAINLESS)	1.000 EA
RM1070A25	O-RING, VITON/FKM .070CS X 6.190ID	1.000 EA
HW4600G01	.984X1.499X.25 VITON SLICK SERIES LIP	1.000 EA
HW4600E99	25 X 42 X 6 AFX SEAL, GRAPHITE INFUSED V	1.000 EA
HW4500S33	1/8 NPT STAINLESS #304 SS PLUG	3.000 EA
HA4054	SHORT T-DRAIN FITTING, .125" N.P.T.	1.000 EA
HW5100A05	WVY WSHR F/205 & 304 BRGS	1.000 EA
35EP1935A02	PULLEY 56C/143-5TC ENCL 205 BRG	1.000 EA
RM1070A25	O-RING, VITON/FKM .070CS X 6.190ID	1.000 EA
HW4600G01	.984X1.499X.25 VITON SLICK SERIES LIP	1.000 EA
HW4600E99	25 X 42 X 6 AFX SEAL, GRAPHITE INFUSED V	1.000 EA
HW4500S33	1/8 NPT STAINLESS #304 SS PLUG	3.000 EA
HA4054	SHORT T-DRAIN FITTING, .125" N.P.T.	1.000 EA
RM1070A26	O-RING,4.5MM I.D.X1.5MM C.S. (VITON)	4.000 EA
35FH4005A39	IEC FH NO GREASER DEBURR/CLEAN - SS	1.000 EA
10XN1032FS06	HEX HD CAP SCREW 10-32 X 3/8 SS FOOD SAF	3.000 EA
RM1070A81	O-RING, -043 VITON/FKM .070CS X 3.489ID	1.000 EA
HW2502D13	SS KEY, 3/16 SQ X 1.375	1.000 EA

Parts List (continued)		
Part Number	Description	Quantity
HA7000A01	KEY RETAINER 7/8" DIA SHAFT	1.000 EA
MJ5001A27	32220KN GRAY SEALER *MIN BUY 4 QTS=1GAL	0.005 QT
MJ5004A93	FOOD GRADE (H1 RATED) ANTISEIZE THRD COM	0.005 EA
MJ1000A02	GREASE, POLYREX EM EXXON (USe 4824-15A)	0.050 LB
19XB0818S12	8-18X3/4 HXWS TYB HIGH-LOW	1.000 EA
WD5603A01	KIT, CLOSED-END LEAD SPLICE (18-14GA)	1.000 EA
HA3100FS25	THRUBOLT, 10-32 X 9.500 SS FOOD SAFE	4.000 EA
36PA1000	PKG GRP, PRINT PK1016A06	1.000 EA
PK3082	STYROFOAM CRADLE	1.000 EA
MN416A01	TAG-INSTAL-MAINT no wire (1200/bx) 5/18	1.000 EA
HA5027A07	85XU1208S08 FACE DRAIN PINS BAGGED	1.000 EA
FE-0000002	ZRTG FE ASSEMBLY	1.000 EA
PE-0000002	ZRTG PE ASSEMBLY	1.000 EA

AC Induction Motor Performance Data

Record # 65604 - Typical performance - not guaranteed values

Winding: 35WGL770-R001	Type: 3528M	Enclosure: TEFC
-------------------------------	--------------------	------------------------

Nameplate Data				460 V, 60 Hz: High Voltage Connection	
Rated Output (HP)	1.5			Full Load Torque	4.46 LB-FT
Volts	230/460			Start Configuration	direct on line
Full Load Amps	4.4/2.2			Breakdown Torque	18.24 LB-FT
R.P.M.	1760			Pull-up Torque	12.1 LB-FT
Hz	60	Phase	3	Locked-rotor Torque	13.05 LB-FT
NEMA Design Code	B	KVA Code	L	Starting Current	18.47 A
Service Factor (S.F.)	1.15			No-load Current	1.28 A
NEMA Nom. Eff.	86.5	Power Factor	75	Line-line Res. @ 25°C	10.45 Ω
Rating - Duty	40C AMB-CONT			Temp. Rise @ Rated Load	58°C
S.F. Amps				Temp. Rise @ S.F. Load	69°C
				Locked-rotor Power Factor	52.7
				Rotor inertia	0.165 LB-FT ²

Load Characteristics 460 V, 60 Hz, 1.5 HP

% of Rated Load	25	50	75	100	125	150	S.F.
Power Factor	33	53	67	75	80	83	78
Efficiency	76.8	85.3	86.7	86.8	86.2	84.8	86.4
Speed	1790	1780	1769	1756	1743	1729	1748
Line amperes	1.35	1.54	1.81	2.15	2.53	2.97	2.38

Performance Graph at 460V, 60Hz, 1.5HP Typical performance - Not guaranteed values

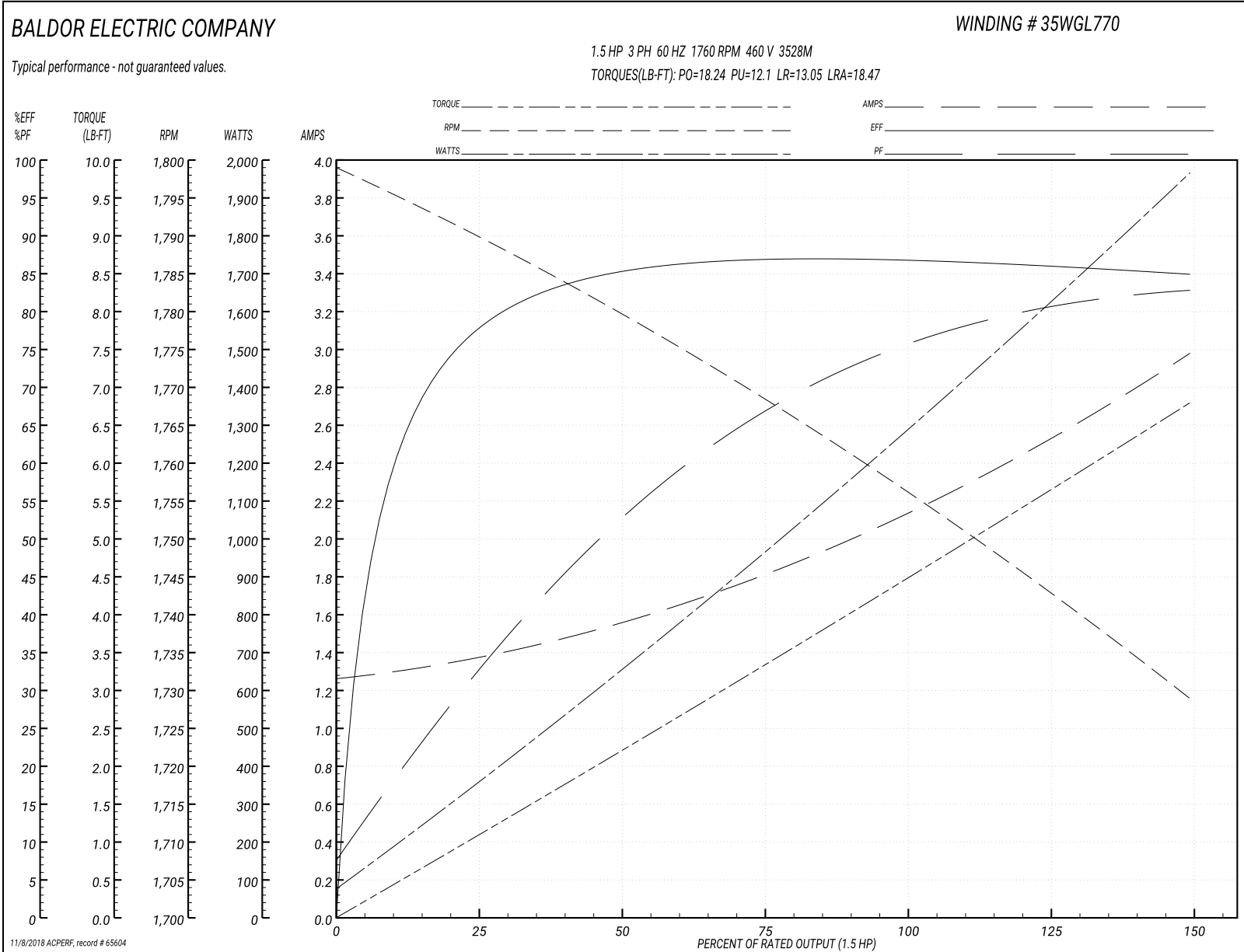

35LYE4709

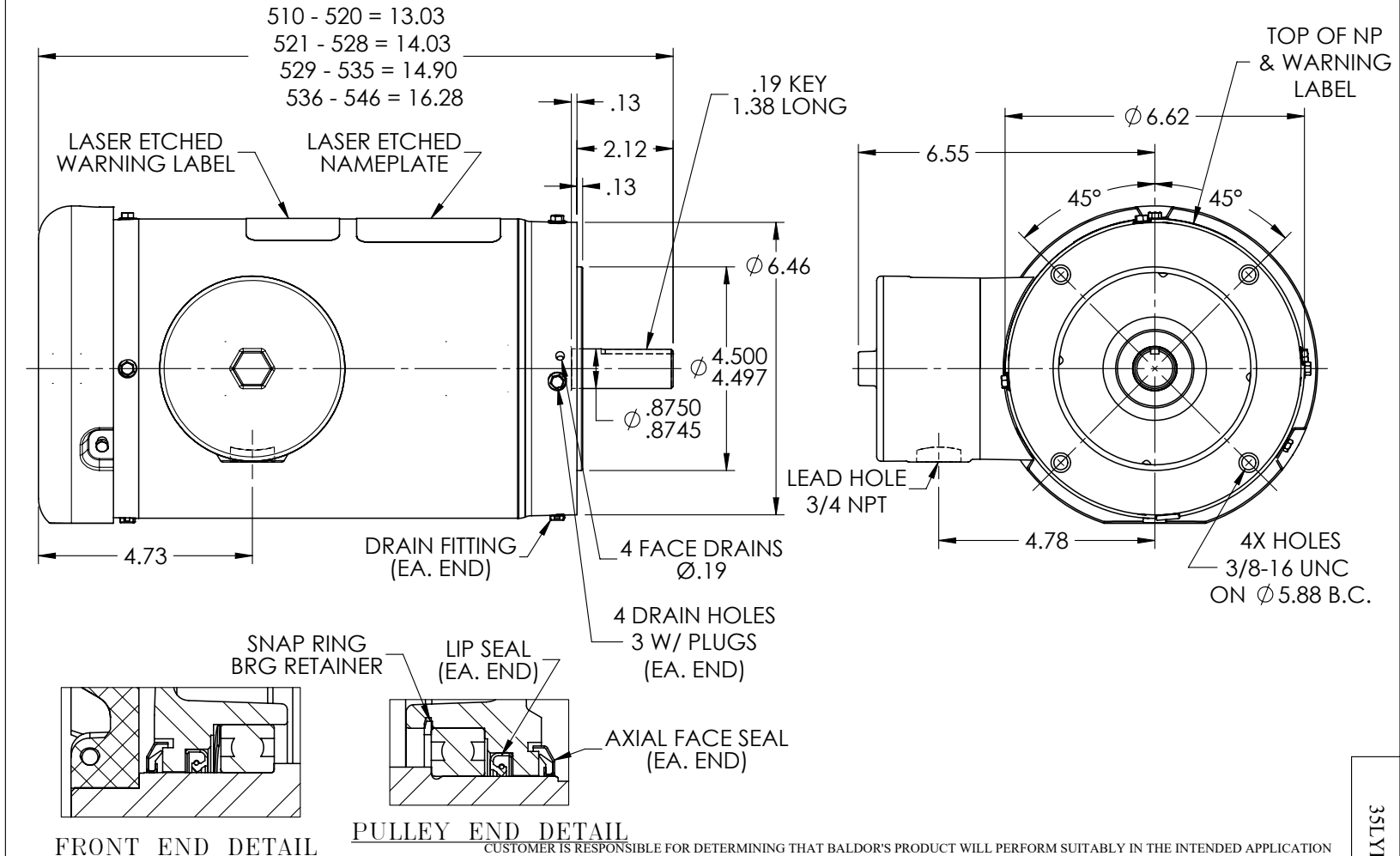

35LYE4709

REV. DESC: RELOCATE THE NAMEPLATE TOWARD THE DRIVE END			
REV: A	VERSION: 01	REVISED: 04:13:06 10/16/2017	TDR: 000001046834
60LYE4709		MODEL NO. 35LYE4709	REF: -
		BY: ENANGGO	

BALDOR

STD VER 143-5TC TEFC 35M WD11/12

CD0005



LOW VOLTAGE
(2Y)



LINE

HIGH VOLTAGE
(1Y)



LINE

NOTES:

1. INTERCHANGE ANY TWO LINE LEADS TO REVERSE ROTATION.
2. OPTIONAL THERMOSTATS ARE PROVIDED WHEN SPECIFIED.
3. ACTUAL NUMBER OF INTERNAL PARALLEL CIRCUITS MAY BE A MULTIPLE OF THOSE SHOWN ABOVE.
4. LEAD COLORS ARE OPTIONAL. LEADS MUST ALWAYS BE NUMBERED AS SHOWN.

REV. DESC: REVISE TO SHOW OPTIONAL COLORS			
REV. LTR: E	BY: JLP	REVISED: 01/19/99 10:15	TDR: 0171435
900000		FILE: AAA00005140	MDL: -
		MTL: -	

BALDOR ELECTRIC Co.

3PH, DV, 9 LEADS

CD0005