

BALDOR® • RELIANCE 

Product Information Packet

VP3436D

.57/.75HP, 1750RPM, DC, D80D, 3428P, TEFC, F2

Part Detail							
Revision:	J	Status:	PRD/A	Change #:		Proprietary:	No
Type:	DC	Prod. Type:	3428P	Elec. Spec:	34WG3946	CD Diagram:	CD0194
Enclosure:	TEFC	Mfg Plant:		Mech. Spec:	34-6483	Layout:	34LY6483
Frame:	D80D	Mounting:	B35	Poles:	00	Created Date:	
Base:	RG	Rotation:	R	Insulation:	F	Eff. Date:	03-05-2018
Field Type:		Literature:		Elec. Diagram:		Replaced By:	

Specs			
Enclosure:	TEFC		
Frame:	D80D		
Frame Material:	Steel		
XP Class and Group:	None		
Agency Approvals:	CE		
	CSA		
	UR		
	WEEE		
Base Indicator:	Rigid		
Bearing Grease Type:	Polyrex EM (-20F +300F)		
Drip Cover:	No Drip Cover		
Duty Rating:	CONT		
Feedback Device:	NO FEEDBACK		
Frame Prefix:	D		
Heater Indicator:	No Heater		
Insulation Class:	F		

Lifting Lugs:	No Lifting Lugs		
Motor Lead Quantity/Wire Size:	2 @ 14 AWG		
Motor Lead Exit:	Ko Box		
Motor Lead Termination:	Flying Leads		
Mounting Arrangement:	B35		
Product Family:	BISSIC		
Pulley End Bearing Type:	Sealed Bearing		
Shaft Extension Location:	Pulley End		
Shaft Ground Indicator:	No Shaft Grounding		
Shaft Rotation:	Reversible		
Shaft Slinger Indicator:	No Slinger		
Motor Standards:	IEC		
XP Division:	Not Applicable		

Nameplate NP1049L			
CAT.NO.	VP3436D		
SPEC.	34-6483-3946		
KW/HP	.57/.75 TE	I.P.	54
RPM	1750 TE		
IEC FRAME	D80D	TYPE	3428P
ARM V	180	ARM A	3.7
FLD V		FLD A	
INSUL	F	AMB.	40
DUTY	CONT	SUPPLY	1.5
BRG/DE	6206	BRG/ODE	6203
BRUSHES	2/BP5000AW14		
SER.		BLANK	
BLANK			
APRV-CE	<input type="checkbox"/>	APRV-CSA	<input type="checkbox"/>
		APRV-UL	<input type="checkbox"/>

Parts List		
Part Number	Description	Quantity
SA053022	SA 34-6483-3946	1.000 EA
AA005944	AA 34-6483-3946	1.000 EA
BP5000AW14SP	CARBON BRUSH - 33P, 180 VOLTS	1.000 EA
HA3210B66	.125 DIA X .281 (AUTO)	2.000 EA
11XW1032G06	10-32 X .38, TAPTITE II, HEX WSHR SLTD U	1.000 EA
34EP3103B14	FR ENDPLATE MACH 34PM TEFC F-2 MTG W/PG-	1.000 EA
WD4100A17	PLUG STIMPSON D4036	1.000 EA
HW5100A03	WAVY WASHER (W1543-017)	1.000 EA
34EP2505A01	FLG MTG EP IEC F165 ENCL 205 BRG MACH.	1.000 EA
HW4600B49	SEAL 0.938 X 1.624 X 0.250 SINGLE LIP DB	1.000 EA
51XN1032A24	10-32 X 1 1/2 HX WS SL SR	2.000 EA
BP5201A11SP	BRUSH HOLDER ASSY W/BP4511A01 & BP3000A0	1.000 EA
80XN1032A03	10-32 X 3/16 SET SCREW	2.000 EA
34FN3002A01SP	EXTERNAL FAN, PLASTIC, .637/.639 HUB W/	1.000 EA
34FH5002A01SP	FAN COVER ASSY W/SHAFT COVER	1.000 EA
51XW1032A06	10-32 X .38, TAPTITE II, HEX WSHR SLTD S	3.000 EA
34CB4504SP	CONDUIT BOX LID, STAMPED	1.000 EA
34GS1011SP	GASKET, CONDUIT BOX LID	1.000 EA
51XW0832A07	8-32 X .44, TAPTITE II, HEX WSHR SLTD SE	2.000 EA
HW3001B02	BRASS CUP WASHER W/GROUND SYMBOL TAB,	1.000 EA
WD4102A01	SR-6L-1 HEYCO STRN RELIEF OR 23MPO6L10 M	1.000 EA
HW2504E10	KEY, 6 MM X 1.000	1.000 EA
HA7000A11	KEY RETAINER 0.750 DIA SHAFTS	1.000 EA
MG1000G27	MED CHARCOAL METALLIC GREY 400-0096	0.014 GA

Parts List (continued)		
Part Number	Description	Quantity
MJ5004A05	#242-21 LOCTITE GENERAL PURPOSE MED. STR	0.001 EA
MJ5001A27	32220KN GRAY SEALER *MIN BUY 4 QTS=1GAL	0.001 QT
85XU0407S04	4X1/4 U DRIVE PIN STAINLESS	2.000 EA
ML14A1B14	14 AWG,A1,BLACK	8.500 IN
ML14A2B14	14 AWG,A2,BLACK	8.500 IN
HA3100A47	THRUBOLT 10-32 X 7.625	4.000 EA
LB1119N	WARNING LABEL	1.000 EA
MN416A01	TAG-INSTAL-MAINT no wire (1200/bx) 5/18	1.000 EA
LC0194	CONNECTION LABEL	1.000 EA
NP1049L	NP STD LASER ENGRAVED IEC DC MOTORS, UL	1.000 EA
27PA1006	PKG GRP, PRINT PK1027A06	1.000 EA

DC Motor Performance Data

Record # 1048 - Typical performance - not guaranteed values

Winding: 34WG3946-R001	Type: 3428P	Enclosure: TEFC
-------------------------------	--------------------	------------------------

Nameplate Data		General Characteristics	
Rated Output (HP)	0.75	Armature Resistance @ 25°C	2.728 Ω
R.P.M.	1750		
Armature Volts	180		
Armature Amps	3.7		
Field Volts		Armature Inductance	27.3166 mH
Field Amps			
Rating - Duty	40C AMB-CONT		
Form Factor	1.5		

Load Characteristics at 180 Armature Volts

Load Point	1	2	3	4	5	6	7
Armature Amps	0.16	1.36	2.56	3.76	5.66	6.72	8.16
R.P.M.	1985	1934	1883	1832	1750	1705	1644
Torque (LB-FT)	0	0.75	1.5	2.25	3.44	4.1	5

Performance Graph at 180.0 Arm V, 0.75HP Typical performance - Not guaranteed values

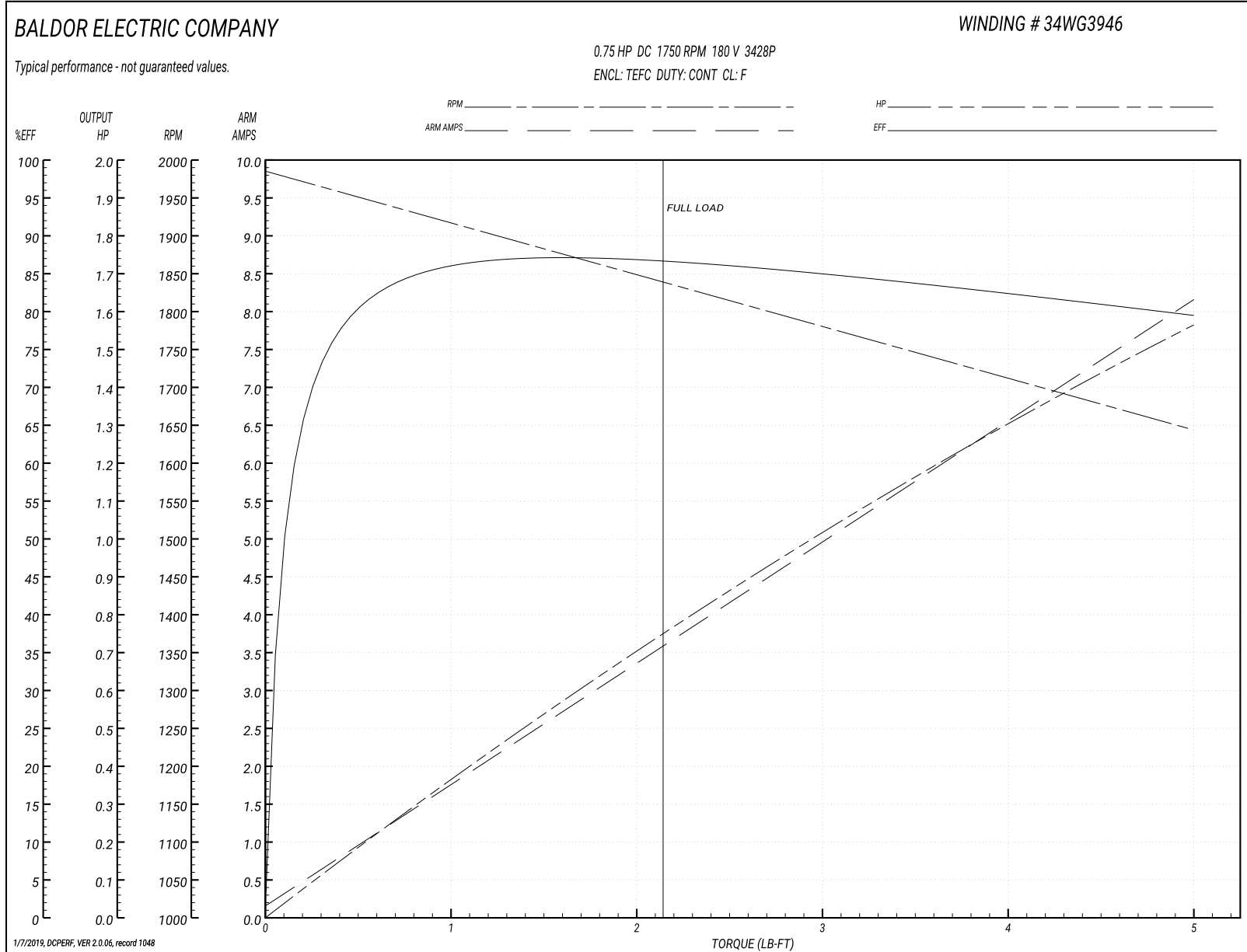

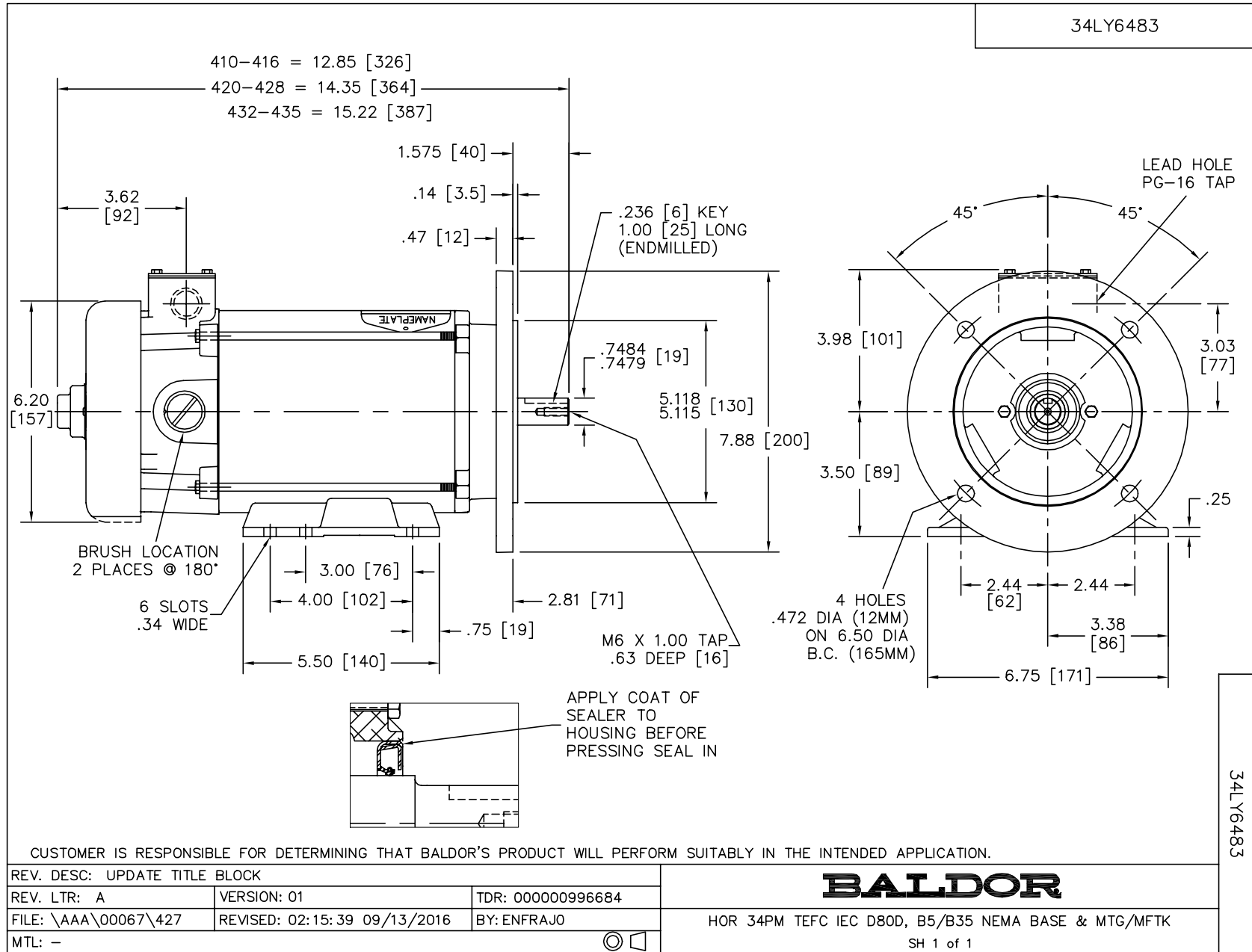

CD0194

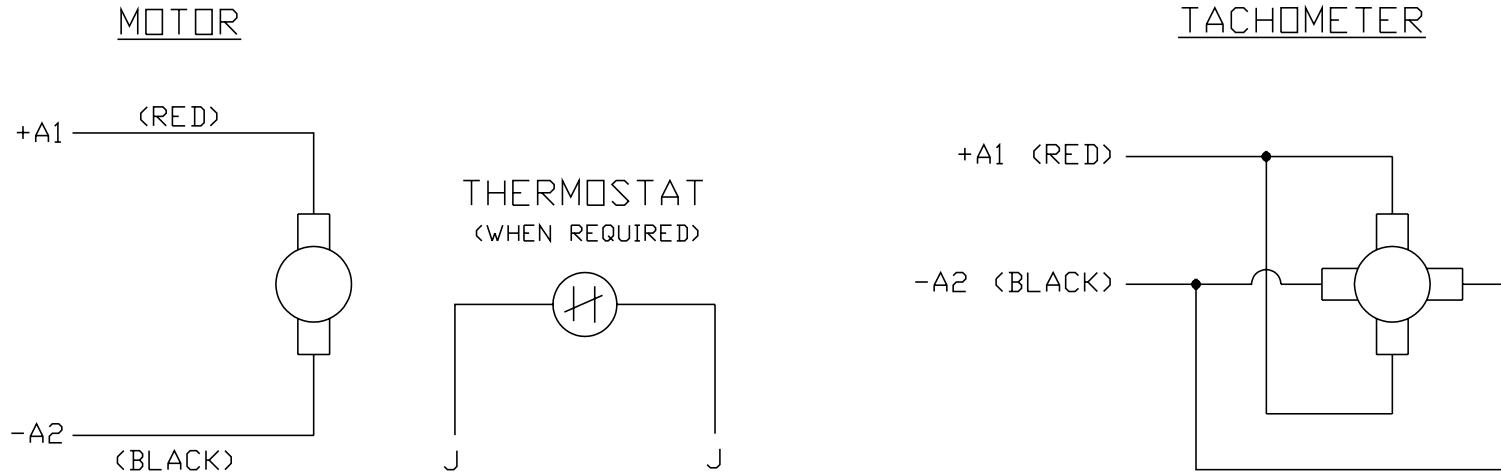

NOTES:

1. CCW ROTATION AS SHOWN FACING COMMUTATOR END. TO REVERSE MOTOR ROTATION OR TACHOMETER OUTPUT POLARITY INTERCHANGE LEADS A1(RED) & A2(BLACK)
2. LEAD COLORS FOR REFERENCE ONLY & NOT SPECIFIED BY THIS DRAWING. LEAD COLORS SPECIFIED BY LAYOUT DRAWING & BILL OF MATERIAL ONLY.

MATL: -			
REV: E	ADDED NOTE "LEAD COLORS FOR REFERENCE ONLY &..."		
761000	SCALE: -	BY: CK	REVISED: 07/28/95
	FILE: AAA00004503		TDR: 0078737

BALDOR ELECTRIC Co.

CD TYPE P DC PERMANENT MAGNET MOTORS AND TACHOMETERS

CD0194