

PRO GRADE™ CONTROL PANEL

Multi-voltage, Single and Three Phase, Simplex or Duplex Pump Control Panels
With Battery Backup, Float Switch and Seal Fail Indicators, and
Over Temperature Protection



This control panel must be installed and serviced by a licensed electrician in accordance with the Canadian Code as well as applicable provincial and local codes.

When installed according to these instructions and Part 1 Section 18 of the Canadian Electrical Code this control panel provides intrinsically safe sensing circuits for interface with Class 1, Zones 0 and 1 hazardous locations. Intrinsically safe wiring must be in accordance with the enclosed control drawing of the specific intrinsically safe relay manufacturer. NEMA 1 enclosures are for indoor use only, primarily to provide a degree of protection against contact with enclosed equipment. Do not use NEMA 1 enclosures if subjected to rain, splashing water or hose-directed water.

INSTALLATION INSTRUCTIONS

1. Mount control panel using integral mounting flanges.
2. Intrinsically Safe Panels: Determine conduit entrance for intrinsically safe wiring. Entrance location must be within intrinsically safe barrier area which is labeled on outside of enclosure. A separate rigid metallic conduit must be used to enclose the conductors of the intrinsically safe control circuit.
3. Determine conduit entrance for non-intrinsically safe wiring. Cables must be at least 2" away from any intrinsically safe conductors.
NOTE: Ensure the power supply voltage and phase are the same as the pump motor being installed. If unsure, refer to the pump identification plate for voltage/phase requirements.
4. Drill holes and attach conduit connectors.
5. Bring cables into the control panel and wire according to the field wiring section of the schematic.
6. Seal conduits using approved sealant to prevent gases from entering the control panel.

Model shown: PG611406X3G5ADEMR6A7A10E15A19BX27A

Dimensions: 16" x 12" x 6"

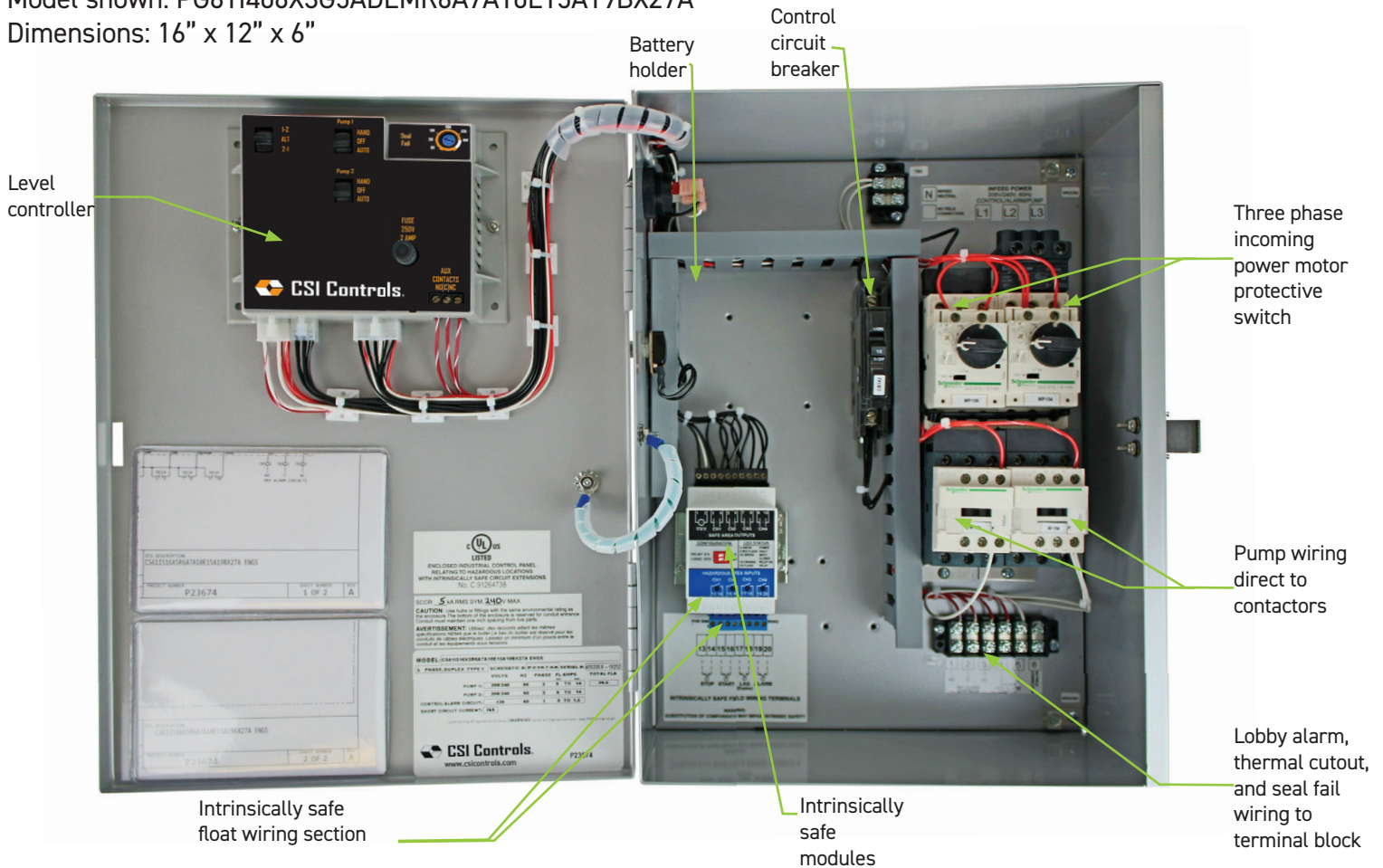

Battery Bracket (Option 3G): Provides 3" x 4" bracket and wires for 12 volt battery back up (battery not included).

Control Circuit Breaker: Provides control/alarm disconnect.

Motor Protective Switch (3 Phase): Each pump circuit has motor protective switches that provides pump disconnect, overload, and branch circuit protection. Adjust overload to pump FLA. Must be vertical to operate.

Contactor: Controls pumps by switching electrical lines. Connect pumps direct to contactors.

Terminal Block: Provides connections for Lobby Alarm, Thermal Cutout, Seal Fail, and Aux Contacts.

Intrinsically Safe Modules (Option 27A): Provides low voltage circuit for floats that are in a hazardous location.

INSTALLATION INSTRUCTIONS



Lead/Lag Selector Switch (Duplex only): Choose which pump operates first or alternate to equal wear.

Seal Fail Circuitry (Option 5E): For use with pumps that monitor seal leak detection. Adjust the knob to the seal fail threshold of the pump.

Pump Hand Off Auto Switch (HOA): In HAND mode, the pump will turn ON. OFF turns pump OFF. In AUTO Mode, commands from the float switches turn each pump ON and OFF.

Fuse: Supplementary fuse protects alarm and control circuits.

Aux Contacts: Form C - can be wired normally open or normally closed.

STANDARD OPERATIONS

The Pro Grade™ control panel operates with float switches. When all floats are in the open or OFF position, the panel is inactive. As the liquid level rises and closes the STOP float, the panel remains inactive until the START float closes. At this point the pump will turn ON (if the Hand-Off-Auto switch is in the AUTO mode and the power is ON). The pump will remain ON until both the STOP and START floats return to their OFF positions. If the liquid level rises beyond both the STOP and START floats to reach the LAG float (Duplex only), the lag pump will turn ON (if the Hand-Off-Auto switch is in the AUTO mode and the power is ON). Both pumps will remain ON until the STOP, LEAD, and LAG floats return to their OFF positions. If the liquid level rises to reach the ALARM float, the alarm will be activated.

- Alarm float will activate pumps until ALARM float and STOP float are down.

Duplex versions:

- If either HOA is in OFF position, the alternate pump will be called for every cycle.
- If pump failure due to MPS trip or thermal cutout then the alternate pump will be called for every cycle.
- Lag Delay will prevent pumps from starting at the same time.

Pipe Clamp Mounting

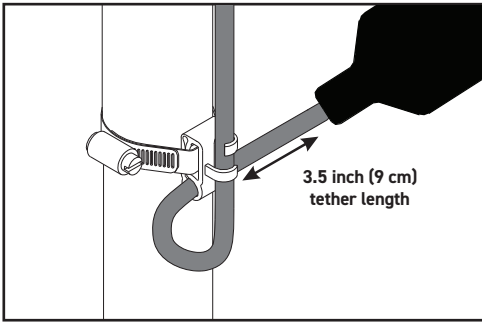

Cable Weight Mounting

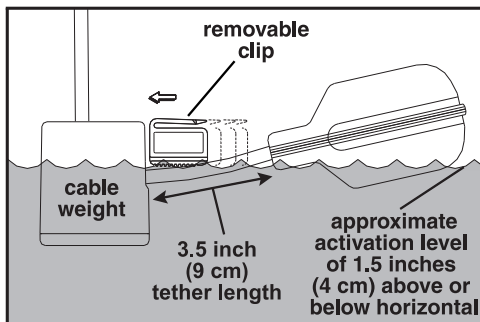

Internal Weight Mounting

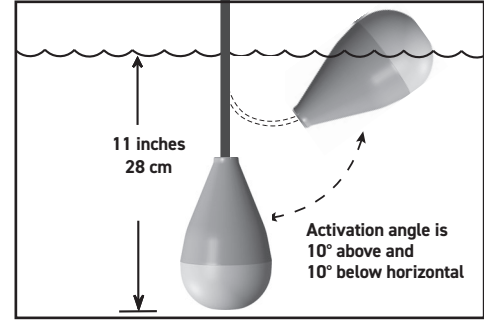

Typical setup for a duplex lift station

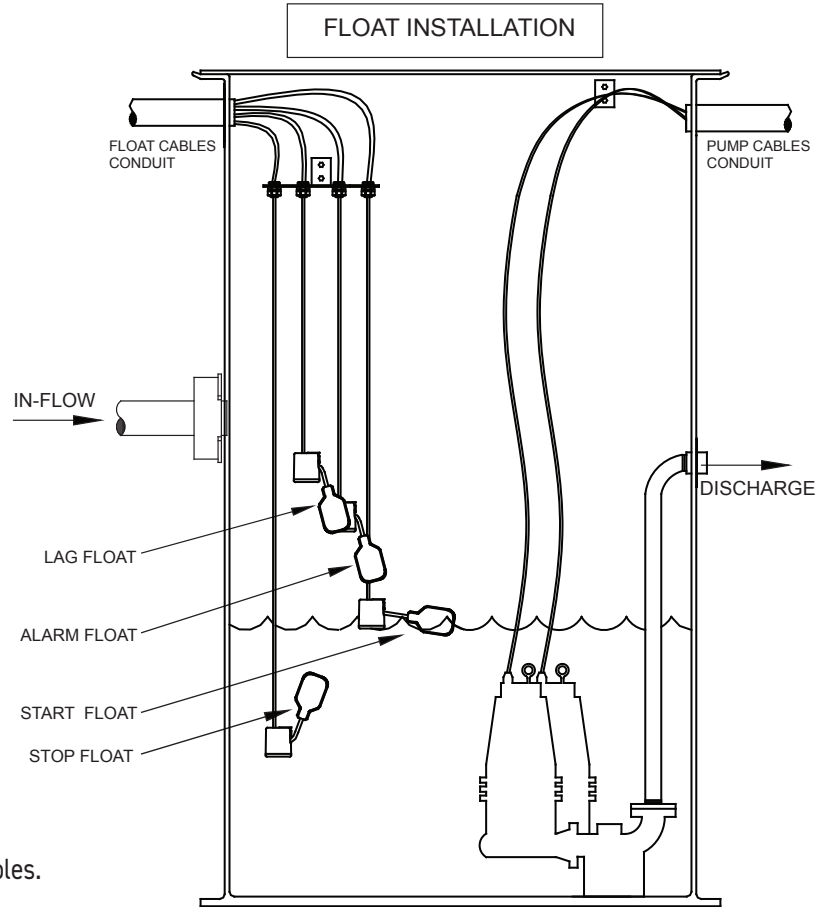

WARNING:
 Keep sensors clear of pumps, pipes, and motor cables.
 Ensure that floats cannot reach pump suction.
 Do not run pump and float cables in the same conduit.

CSI CONTROLS® FIVE-YEAR LIMITED WARRANTY

Five-Year Limited Warranty.
 For complete terms and conditions, please visit www.csicontrols.com.
 Warranty void if panel is modified.



CSI Controls®

Technical support: +1-800-746-6287
techsupport@sjeinc.com
www.csicontrols.com

PN 1063832B 9/19 © 2019 SJE, Inc. All Rights reserved. CSI CONTROLS is a trademark of SJE, Inc.