



TYPE "B" SINGLE STAGE CENTRIFUGAL PUMP Electric Motor Drive

Section	CC
Page	110.1
Date	January 1, 2004
Supersedes 6/1/95	

CAST IRON IMPELLER

B2EPBHH

Threaded Case (NPT)

Packing Construction

TABLE I

B/M No.	HP	PH	RPM	"U" Dim.	Imp. Dia.	Imp. No.
B55841	50	3	3600	1-1/4"	9.38"	M07694
B55842	60	3	3600	1-1/4"	10.06"	M07695

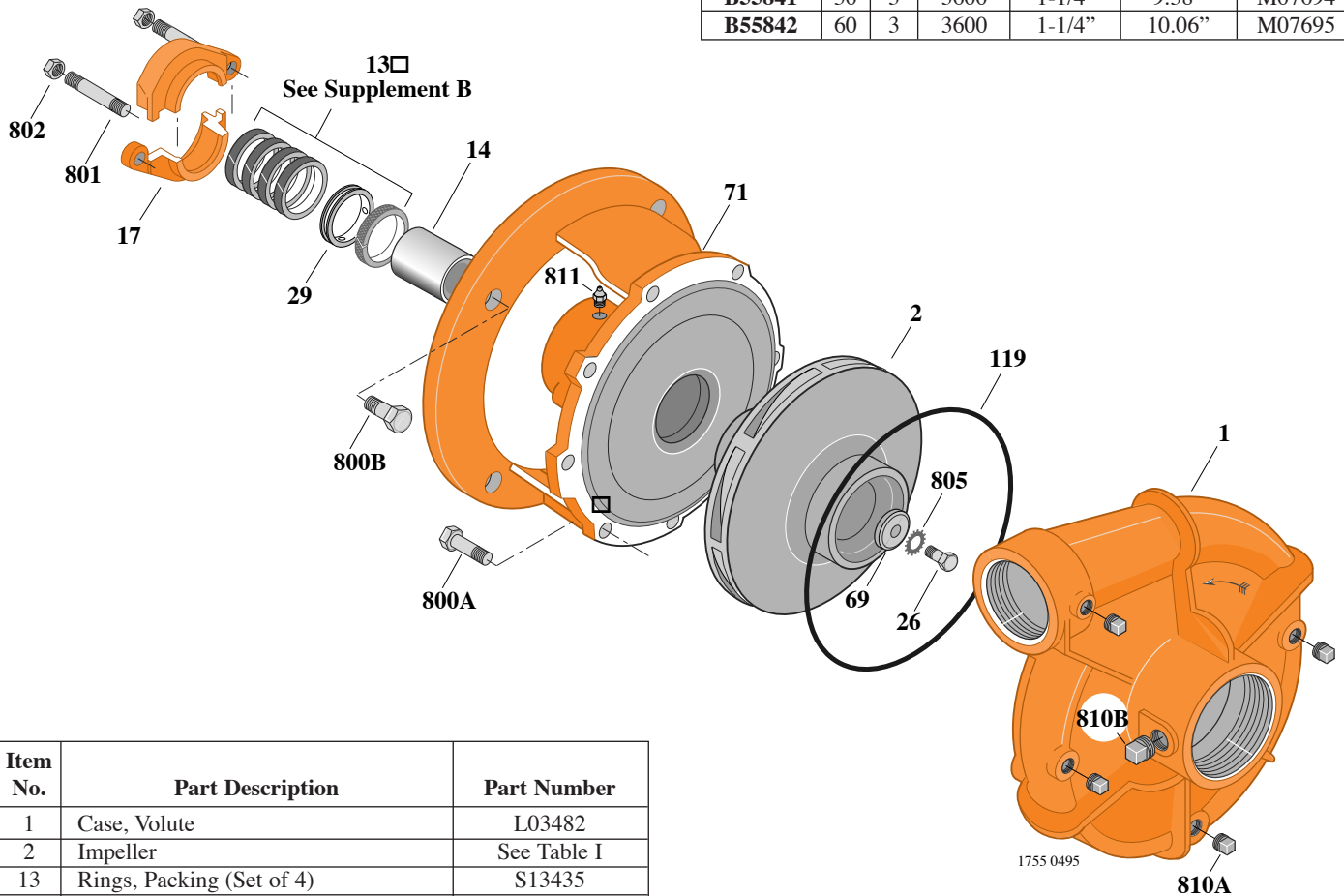

Item No.	Part Description	Part Number
1	Case, Volute	L03482
2	Impeller	See Table I
13	Rings, Packing (Set of 4)	S13435
14	Sleeve, Shaft	S05149
17	Gland, Packing	B82470
26	Screw, Impeller 1/2 - 13 x 1-1/4"	S23621
29	Ring, Lantern	S19200
32	Key, 1/4 x 2-1/4" (See Note)	S23677
69	Washer, Impeller	S06319
71	Bracket	See Table II
119	O-Ring	S13760
800A	Capscrew, 1/2 - 13 x 1-1/4" (8 Req.)	S26914
800B	Capscrew, 5/8 - 11 x 1-1/2" (4 Req.)	S26999
801	Stud, 3/8 - 16 x 2-1/2" (2 Req.)	S04483
802	Nut, Hex 3/8 - 16 (2 Req.)	S23343
805	Washer, Lock	S23038
810A	Plug, Pipe 1/4 NPT (4 Req.)	S23715
810B	Plug, Pipe 1/2 NPT	S23717
811	Fitting, Grease	S23700

TABLE II

HP	PH	Bracket No.	"AK" Fit	"U" Dim.	Motor Frame
50	3	L03712	12-1/2"	1-1/4"	324JP
60	3	L03712	12-1/2"	1-1/4"	326JP

NOTE: For an explanation of the tabulated material found on this page and for impeller key location, refer to *Supplement A* located at the beginning of this section.



TYPE "B" SINGLE STAGE CENTRIFUGAL PUMP Electric Motor Drive

Section	CC
Page	110.2
Date	January 1, 2004
Supersedes 6/1/95	

CAST IRON IMPELLER

B2EPBHHS

Threaded Case (NPT)

Mechanical Shaft Seal Construction

TABLE I

B/M No.	HP	PH	RPM	"U" Dim.	Imp. Dia.	Imp. No.
B55843	50	3	3600	1-1/4"	9.38"	M07694
B55844	60	3	3600	1-1/4"	10.06"	M07695

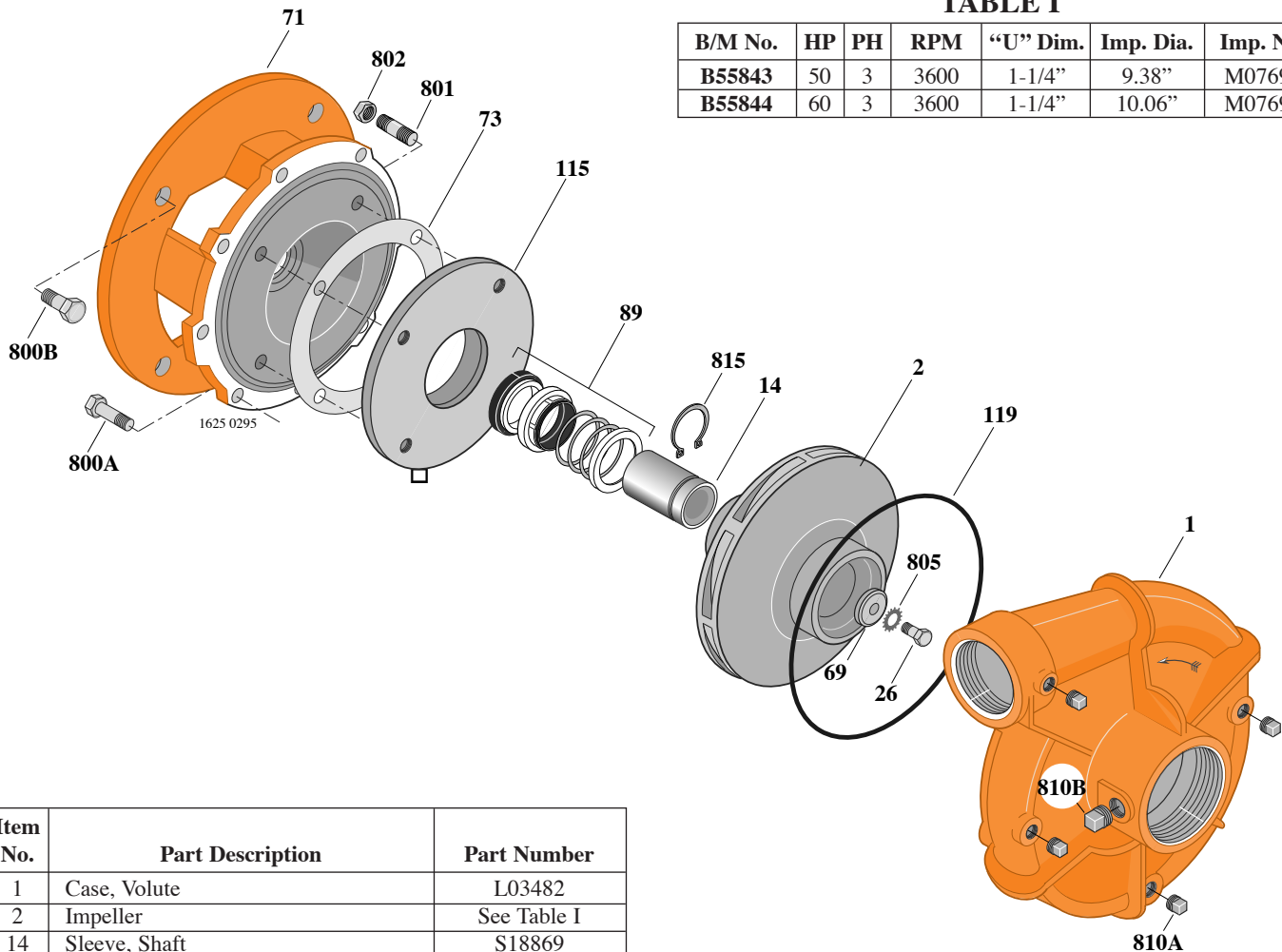

Item No.	Part Description	Part Number
1	Case, Volute	L03482
2	Impeller	See Table I
14	Sleeve, Shaft	S18869
26	Screw, Impeller 1/2 - 13 x 1-1/4"	S23621
32	Key, 1/4 x 2-1/4" (See Note)	S23677
69	Washer, Impeller	S06319
71	Bracket	See Table II
73	Gasket, Balance Ring	S09943
89	Seal, Shaft	M10227
115	Ring, Balance	S19262
119	O-Ring	S13760
800A	Capscrew, 1/2 - 13 x 1-1/4" (8 Req.)	S26914
800B	Capscrew, 5/8 - 11 x 1-1/2" (4 Req.)	S26999
801	Stud, 3/8 - 16 x 1-1/4" (4 Req.)	S23994
802	Nut, 3/8 - 16 (4 Req.)	S23103
805	Washer, Lock	S23038
810A	Plug, Pipe 1/4 NPT (4 Req.)	S23715
810B	Plug, Pipe 1/2 NPT	S23717
815	Ring, Retaining	S16767

TABLE II

HP	PH	Bracket No.	"AK" Fit	"U" Dim.	Motor Frame
50	3	L04628	12-1/2"	1-1/4"	324JM
60	3	L04628	12-1/2"	1-1/4"	326JM

NOTE: For an explanation of the tabulated material found on this page and for impeller key location, refer to *Supplement A* located at the beginning of this section.



TYPE "B" SINGLE STAGE CENTRIFUGAL PUMP Electric Motor Drive

Section	CC
Page	110.3
Date	January 1, 2004
Supersedes/NEW	

BRONZE IMPELLER

B2EPBHHS

Threaded Case (NPT)

Mechanical Shaft Seal Construction

TABLE I

B/M No.	HP	PH	RPM	"U" Dim.	Imp. Dia.	Imp. No.
B77327	50	3	3600	1-1/4"	9.38"	M11579
B66867S	60	3	3600	1-1/4"	10.06"	L08529

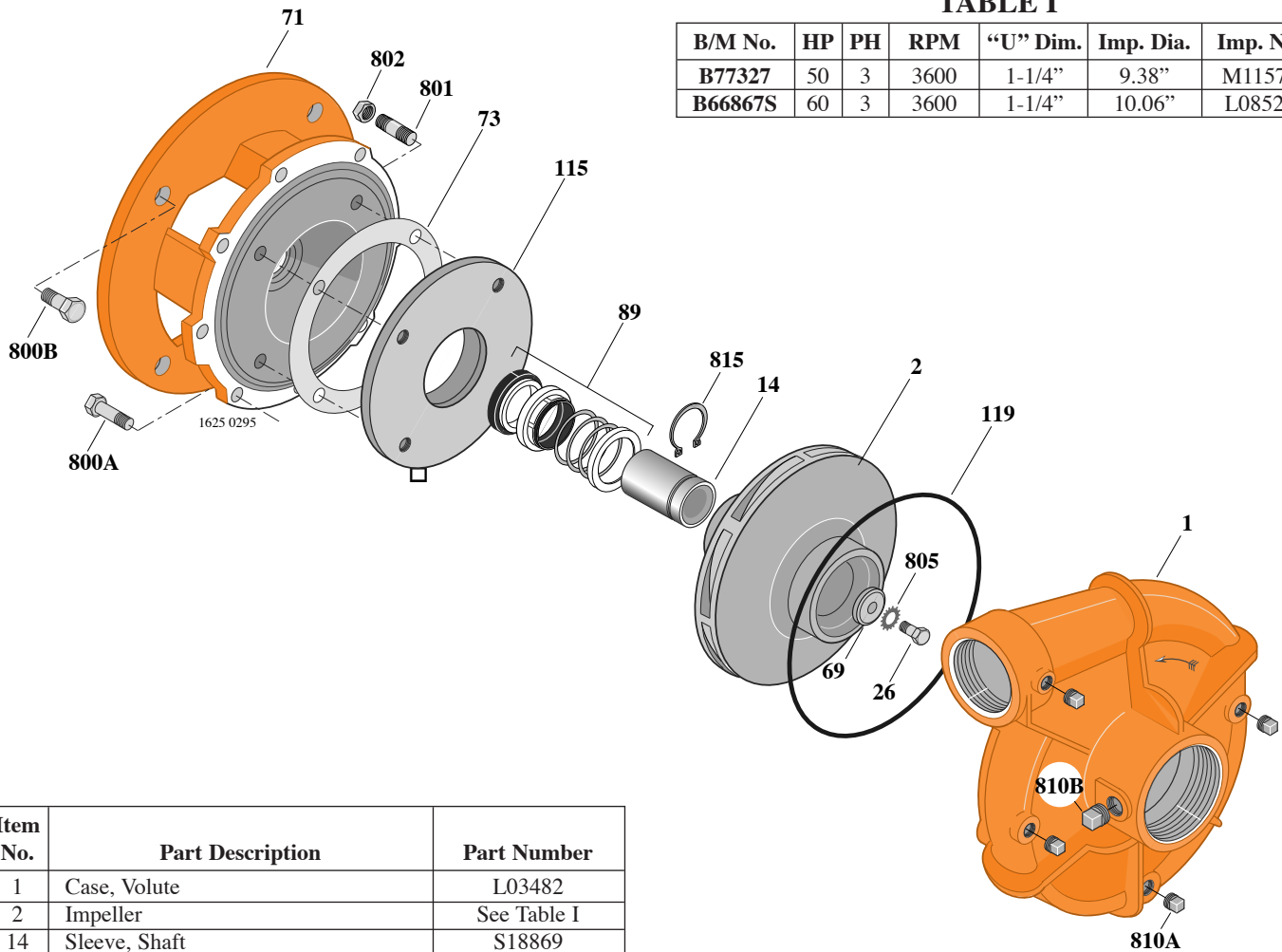

Item No.	Part Description	Part Number
1	Case, Volute	L03482
2	Impeller	See Table I
14	Sleeve, Shaft	S18869
26	Screw, Impeller 1/2 - 13 x 1-1/4"	S23621
32	Key, 1/4 x 2-1/4" (See Note)	S23677
69	Washer, Impeller	S06319
71	Bracket	See Table II
73	Gasket, Balance Ring	S09943
89	Seal, Shaft	M10227
115	Ring, Balance	S19262
119	O-Ring	S13760
800A	Capscrew, 1/2 - 13 x 1-1/4" (8 Req.)	S26914
800B	Capscrew, 5/8 - 11 x 1-1/2" (4 Req.)	S26999
801	Stud, 3/8 - 16 x 1-1/4" (4 Req.)	S23994
802	Nut, 3/8 - 16 (4 Req.)	S23103
805	Washer, Lock	S23038
810A	Plug, Pipe 1/4 NPT (4 Req.)	S23715
810B	Plug, Pipe 1/2 NPT	S23717
815	Ring, Retaining	S16767

TABLE II

HP	PH	Bracket No.	"AK" Fit	"U" Dim.	Motor Frame
50	3	L04628	12-1/2"	1-1/4"	324JM
60	3	L04628	12-1/2"	1-1/4"	326JM

NOTE: For an explanation of the tabulated material found on this page and for impeller key location, refer to *Supplement A* located at the beginning of this section.



TYPE "B" SINGLE STAGE CENTRIFUGAL PUMP Electric Motor Drive

Section	CC
Page	110.4
Date	January 1, 2004
Supersedes/NEW	

BRONZE IMPELLER

B2EPBHHS

Flanged Case

Mechanical Shaft Seal Construction

TABLE I

B/M No.	HP	PH	RPM	"U" Dim.	Imp. Dia.	Imp. No.
B76791	50	3	3600	1-1/4"	9.38"	M11579
B76792	60	3	3600	1-1/4"	10.06"	L08529

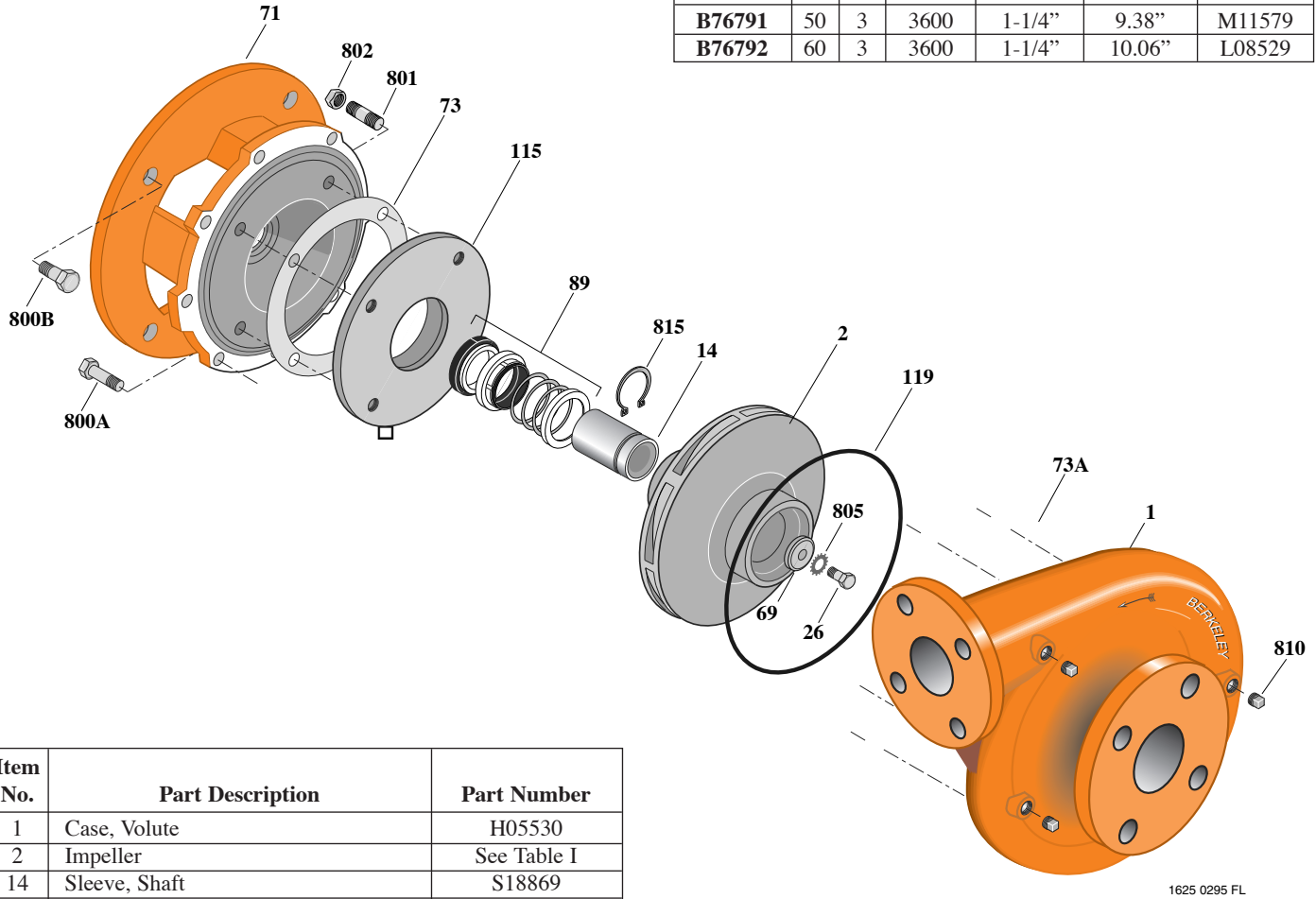

Item No.	Part Description	Part Number
1	Case, Volute	H05530
2	Impeller	See Table I
14	Sleeve, Shaft	S18869
26	Screw, Impeller 1/2 - 13 x 1-1/4"	S23621
32	Key, 1/4 x 2-1/4" (See Note)	S23677
69	Washer, Impeller	S06319
71	Bracket	See Table II
73	Gasket, Balance Ring	S09943
89	Seal, Shaft	M10227
115	Ring, Balance	S19262
119	O-Ring	S13760
800A	Capscrew, 1/2 - 13 x 1-1/4" (8 Req.)	S26914
800B	Capscrew, 5/8 - 11 x 1-1/2" (4 Req.)	S26999
801	Stud, 3/8 - 16 x 1-1/4" (4 Req.)	S23994
802	Nut, 3/8 - 16 (4 Req.)	S23103
805	Washer, Lock	S23038
810A	Plug, Pipe 1/4 NPT (4 Req.)	S23715
810B	Plug, Pipe 1/2 NPT	S23717
815	Ring, Retaining	S16767

TABLE II

HP	PH	Bracket No.	"AK" Fit	"U" Dim.	Motor Frame
50	3	L04628	12-1/2"	1-1/4"	324JM
60	3	L04628	12-1/2"	1-1/4"	326JM

NOTE: For an explanation of the tabulated material found on this page and for impeller key location, refer to *Supplement A* located at the beginning of this section.