

**BALDOR® • RELIANCE** 

**Product Information Packet**

**ZDVSCP4115T**

**50HP,1775RPM,3PH,60HZ,326T,1272M,TEFC,F1**

Part Detail							
Revision:	D	Status:	PRD/A	Change #:		Proprietary:	No
Type:	AC	Elec. Spec:	12WGY141	CD Diagram:	CD0180	Mfg Plant:	
Mech. Spec:	12G537	Layout:	12LYG537	Poles:	04	Created Date:	10-16-2015
Base:	RG	Eff. Date:	06-21-2018	Leads:	9#6		

Specs			
Catalog Number:	ZDVSCP4115T	Insulation Class:	F
Enclosure:	TEFC	Inverter Code:	Inverter Duty
Frame:	326T	KVA Code:	H
Frame Material:	Iron	Lifting Lugs:	Standard Lifting Lugs
Output @ Frequency:	50.000 HP @ 60 HZ	Locked Bearing Indicator:	Locked Bearing
Synchronous Speed @ Frequency:	1800 RPM @ 60 HZ	Motor Lead Quantity/Wire Size:	9 @ 6 AWG
Voltage @ Frequency:	230.0 V @ 60 HZ	Motor Lead Exit:	Ko Box
	460.0 V @ 60 HZ	Motor Lead Termination:	Flying Leads
XP Class and Group:	None	Motor Type:	1272M
XP Division:	Not Applicable	Mounting Arrangement:	F1
Agency Approvals:	UR	Power Factor:	85
	CSA	Product Family:	Chemical Processing (Not DC)
Auxillary Box:	No Auxillary Box	Pulley End Bearing Type:	Ball
Auxillary Box Lead Termination:	None	Pulley Face Code:	Standard
Base Indicator:	Rigid	Pulley Shaft Indicator:	Standard
Bearing Grease Type:	Polyrex EM (-20F +300F)	Rodent Screen:	None
Blower:	None	Shaft Extension Location:	Pulley End
Current @ Voltage:	116.000 A @ 230.0 V	Shaft Ground Indicator:	No Shaft Grounding

	58.000 A @ 460.0 V	<b>Shaft Rotation:</b>	Reversible
<b>Design Code:</b>	A	<b>Shaft Slinger Indicator:</b>	Shaft Slinger
<b>Drip Cover:</b>	No Drip Cover	<b>Speed Code:</b>	Single Speed
<b>Duty Rating:</b>	CONT	<b>Motor Standards:</b>	NEMA
<b>Electrically Isolated Bearing:</b>	Not Electrically Isolated	<b>Starting Method:</b>	Direct on line
<b>Feedback Device:</b>	TACHOMETER	<b>Thermal Device - Bearing:</b>	NONE (OLD)
<b>Front Face Code:</b>	Standard	<b>Thermal Device - Winding:</b>	Normally Closed Thermostat
<b>Front Shaft Indicator:</b>	None	<b>Vibration Sensor Indicator:</b>	No Vibration Sensor
<b>Heater Indicator:</b>	No Heater	<b>Winding Thermal 1:</b>	None
		<b>Winding Thermal 2:</b>	None

Nameplate NP3303L	
CAT NO	ZDVSCP4115T
SPEC.	12G537Y141Z1
FRAME	326T HP 50 TE
VOLTS	230/460
MAG CUR	40/20 FLA 116/58
RPM	1775 RPM MAX 2700
HZ	60 PH 3 CLASS F
SER.F.	1.00 SL HZ 0.8
NEMA-NOM-EFF	94.5 WK2 9.59
RATING	40C AMB-CONT
DE BRG	6312 ODE BRG 6312
CC	010A SN
	1.5:1 CHP PWM

Nameplate NP0090L	
FRONT	6312
PULLEY	6312
LUBRICATE WITH	
GREASE	POLYREX EM

Parts List		
Part Number	Description	Quantity
SA309109	SA 12G537Y141Z1	1.000 EA
RA296450	RA 12G537Y141Z1	1.000 EA
09FN3001C03	EXTERNAL FAN, PLASTIC	1.000 EA
10CB1000A203P	CONDUIT BOX, MACH W/EPOXY PRIMER	1.000 EA
09GS1010	GASKET, DWG, LEADWIRE SEPERATOR	1.000 EA
10XN3118K16	5/16-18 X 1' GRADE #5, STL, ZINC PLATE	4.000 EA
HW1001A31	LOCKWASHER 5/16, ZINC PLT.591 OD, .319 I	4.000 EA
WD1000B25	GND LUG, BURNDY L125HP OR T&B L125HP-BB	1.000 EA
19XW3118G08	.31-18X.50,HEX WSHR HD,TAPTITE 2,GREEN	1.000 EA
HW1001A31	LOCKWASHER 5/16, ZINC PLT.591 OD, .319 I	1.000 EA
HW1001A25	LOCKWASHER 1/4, ZINC PLT .493 OD, .255 I	1.000 EA
HA4017A11	1/8 X 2.75 GREASE EXT (F/S)	1.000 EA
HW4019A01	PIPE COUPLING 1/8 NPT,STEEL,ZINC COATING	1.000 EA
HA4017A01	1/8 X 4 GREASE EXT (F/S)	1.000 EA
HA3400A13	STUD, 1/2-13 X 7" WELKER	4.000 EA
HW1001A50	LOCKWASHER 1/2, ZINC PLT.,.879 OD, .509 I	4.000 EA
HA1005A04	SLINGER, OD 3.620, ID 1.98,	1.000 EA
HW5100A15	W4997-050 WVY WSHR (WB)	1.000 EA
HW4500A20	1/8NPT SL PIPE PLUG	1.000 EA
10XN3118K40	5/16-18 X 2.50" HEX HD, GRADE 5	4.000 EA
12FH1002A58P	FAN COVER, MACH W/EPOXY PRIMER	1.000 EA
12EP1111A30P	SPL PUEP 312 BRG W/EPOXY	1.000 EA
10XN5013K28	1/2-13 X 1.75 HEX HEAD MACH SCREW,GRAD	4.000 EA
HW1001A50	LOCKWASHER 1/2, ZINC PLT.,.879 OD, .509 I	4.000 EA

Parts List (continued)		
Part Number	Description	Quantity
HW4500A20	1/8NPT SL PIPE PLUG	1.000 EA
HW4600B41	V-RING SLINGER 2.125 X 2.880 X 0.280	1.000 EA
10XN3118K40	5/16-18 X 2.50" HEX HD, GRADE 5	4.000 EA
XY5013A12	NUT,1/2-13,HEX,STEEL,ZINCPLATED	4.000 EA
HW1001A50	LOCKWASHER 1/2, ZINC PLT, .879 OD, .509 I	4.000 EA
611712073A	TACH 210	1.000 EA
10XN2520K12	1/4-20 X.75 GRD 5	1.000 EA
10XN2520K12	1/4-20 X.75 GRD 5	2.000 EA
HW1000A25	1/4 SAE FLAT WASHER (FS)	2.000 EA
HW1001A25	LOCKWASHER 1/4, ZINC PLT .493 OD, .255 I	2.000 EA
10CB1503A01P	CONDUIT BOX LIPPED LID, MACH W/EPXY PRMR	1.000 EA
14GS1003	GASKET CONDUIT BOX LID, NEOP	1.000 EA
10XN2520K16	1/4-20 X 1" HX HD SCRW GRADE 5, ZINC P	4.000 EA
HW1001A25	LOCKWASHER 1/4, ZINC PLT .493 OD, .255 I	4.000 EA
HW2501H34	KEY, 1/2 SQ X 4.00	1.000 EA
MJ5001A27	32220KN GRAY SEALER *MIN BUY 4 QTS=1GAL	0.031 QT
MJ5001A14	DYNAPRO SEALANT, CP MTR VC#2508050 (603	0.033 EA
MJ5002A01	SILICON RUBBER SEALANT, 732CL 10.3 OZ TU	0.025 EA
LB1115N	LABEL,LIFTING DEVICE (ON ROLLS)	1.000 EA
LB1002N	LABEL,MARINE DUTY (ON ROLLS)	1.000 EA
12EP1111A57GP6	FR ENDPLATE, MACH W/EPOXY PRIMER & RELIA	1.000 EA
HA4051A00	PLASTIC CAP FOR GREASE FITTING	1.000 EA
HW4500A21	1618BALEMITE FITTING 825 UNIVERSAL	1.000 EA
HW4500A17	317400 ALEMITE GREASE RELIEF	1.000 EA

Product Information Packet: ZDVSCP4115T - 50HP,1775RPM,3PH,60HZ,326T,1272M,TEFC,F1

HA4054	SHORT T-DRAIN FITTING, .125" N.P.T.	1.000 EA
MJ1000A02	GREASE, POLYREX EM EXXON (USe 4824-15A)	0.200 LB
HA4051A00	PLASTIC CAP FOR GREASE FITTING	1.000 EA
HW4500A03	GREASE FITTING, .125 NPT 1610(ALEMITE) 8	1.000 EA
HW4500A17	317400 ALEMITE GREASE RELIEF	1.000 EA
HA4054	SHORT T-DRAIN FITTING, .125" N.P.T.	1.000 EA
51XB1214A20	12-14X1.25 HXWSSLD SERTYB	1.000 EA
HW2500A25	WOODRUFF KEY USA #1008 #BLOW CARBON STEE	1.000 EA
MG1025N19	WILKOFAS, 778.50, RELIANCE BLUE-GREEN	0.080 GA
85XU0407S04	4X1/4 U DRIVE PIN STAINLESS	4.000 EA
LB1119N	WARNING LABEL	1.000 EA
LC0181	CONNECTION LABEL	1.000 EA
NP3303L	SS VEC UL CSA CC (W/OUT DESIGN FIELD)	1.000 EA
NP0090L	NP BRG INFO LASER ETCHED	1.000 EA
10PA1010	PACKAGING GROUP, PRINT PK1151A06	1.000 EA
MN416A01	TAG-INSTAL-MAINT no wire (1200/bx) 5/18	1.000 EA



NP VOLTS	230/460	MAX SAFE RPM	2700	WYE CONN EQ.CKT OHMS PER PHASE (BASE RATING, 200)			
NP AMPS	116/58	Base Volt	460	R1	0.056	X1	0.352
HP	50HP	NL AMPS	19.8	R2	0.050	X2	0.440
BASE SPEED	1775	Slips	0.83			XM	11.900
PHASE/HZ	3/60	WK <sup>2</sup> (lb-ft <sup>2</sup> )	9.59				

**Rated Full Load Data**

	RPM	HP	Torque	Volts	Freq-Hz	Amps
Base Speed	1778	49.8	147.0	460	60	57.6
Max Speed	2665	49.8	98.1	460	90	56.0
Min Speed	0	0.0	147.0	14.88	0.83	57.6

**Load Performance at Base Speed**

	RPM	HP	Torque	Volts	Freq-Hz	Amps
No Load	1799	0.0	0.0	460	60	19.8
1/4	1795	12.3	36.1	460	60	24.2
1/2	1789	24.8	72.8	460	60	33.5
3/4	1784	37.4	110.0	460	60	44.7
Full Load	1778	49.8	147.0	460	60	57.6
O/L	1754	99.6	298.0	460	60	116.0

Blower Data	Volts	Pn/Hz	FL Amps	LR Amps	Frame	CFM

Remarks: Calculated Data  
Vector PWM Inverter Duty

 A MEMBER OF THE ABB GROUP	DR BY	BR	A-C MOTOR PERFORMANCE CURVES
	CK BY	BR	
	APP BY	BR	
	DATE	10/16/2015	

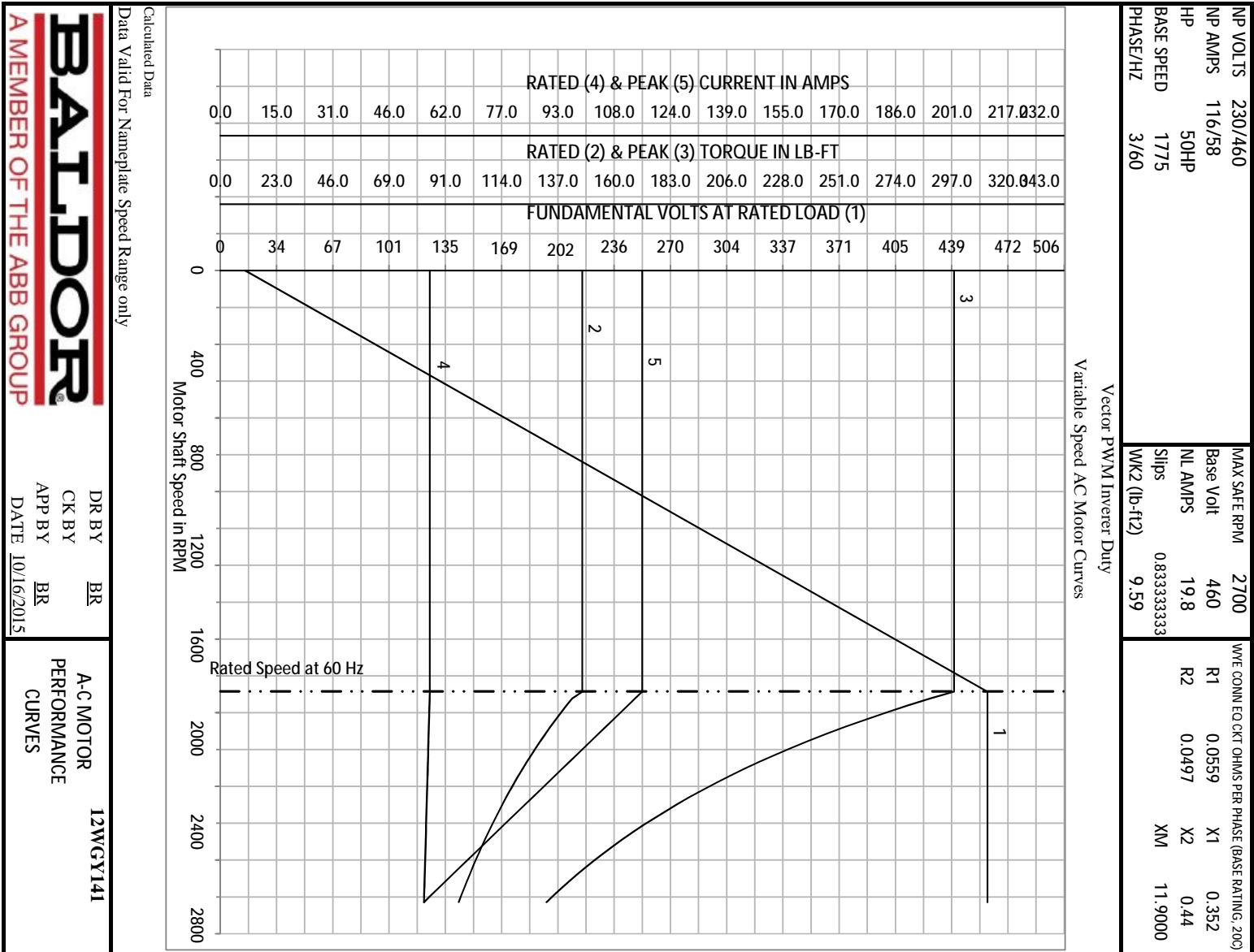

NP VOLTS	230/460	MAX SAFE RPM	2700	WYE CONN. EQ. CT. OHMS PER PHASE (BASE RATING, 200)			
NP AMPS	116/58	Base Volt	460	R1	0.0559	X1	0.352
HP	50HP	NL AMPS	19.8	R2	0.0497	X2	0.44
BASE SPEED	1775	Slips	0.833333333			XM	11.9
PHASE/HZ	3/60	WK2 (lb-ft <sup>2</sup> )	9.59				

Vector PWM Inverter Duty  
Variable Speed AC Motor Curves

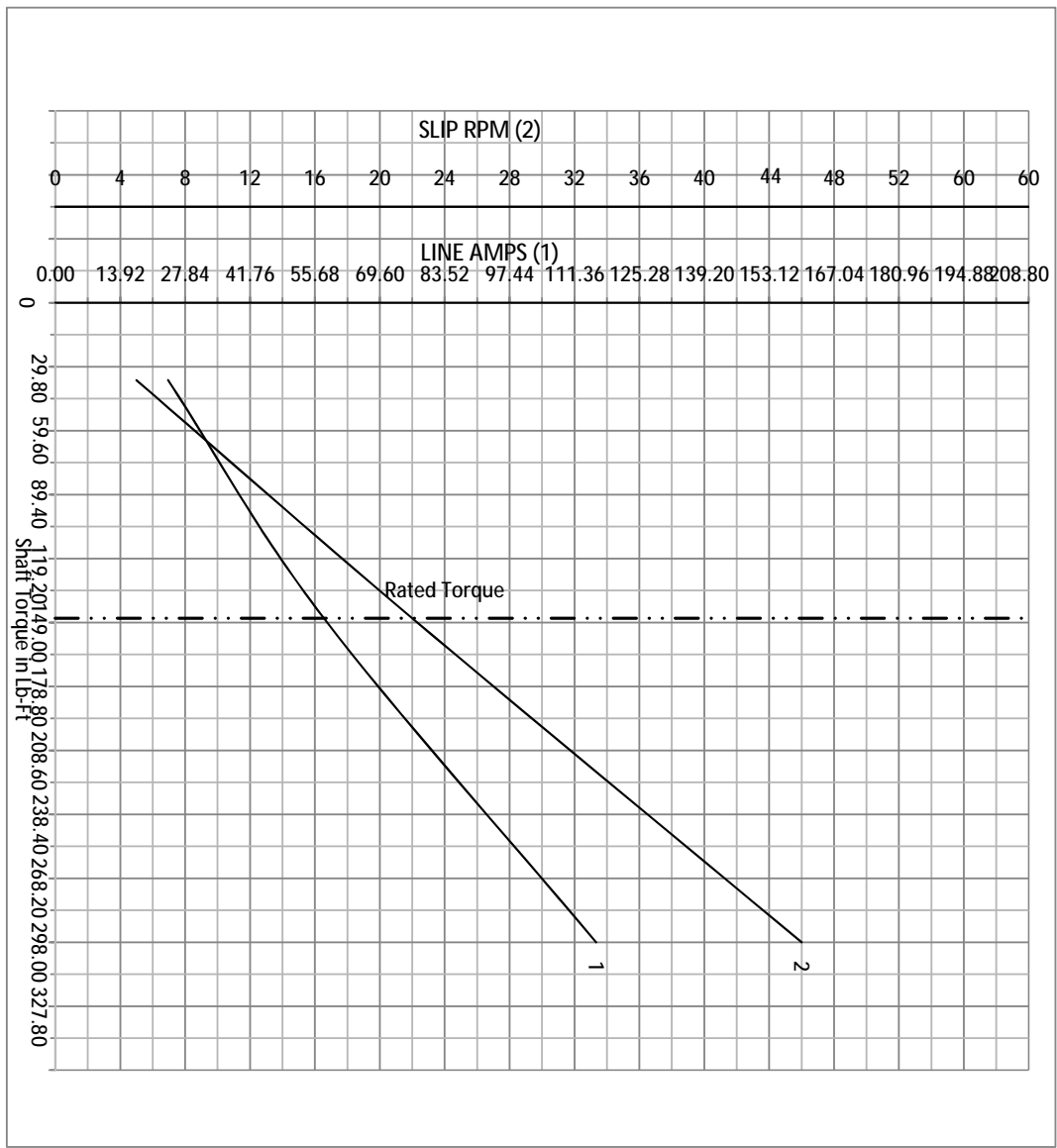

Calculated Data

Data Valid For Nameplate Speed Range only

**BALDOR**  
A MEMBER OF THE ABB GROUP

DR BY	BR	A-C MOTOR	12WG141
CK BY	BR	PERFORMANCE	
APP BY	BR	CURVES	
DATE	10/16/2015		

12LY6537

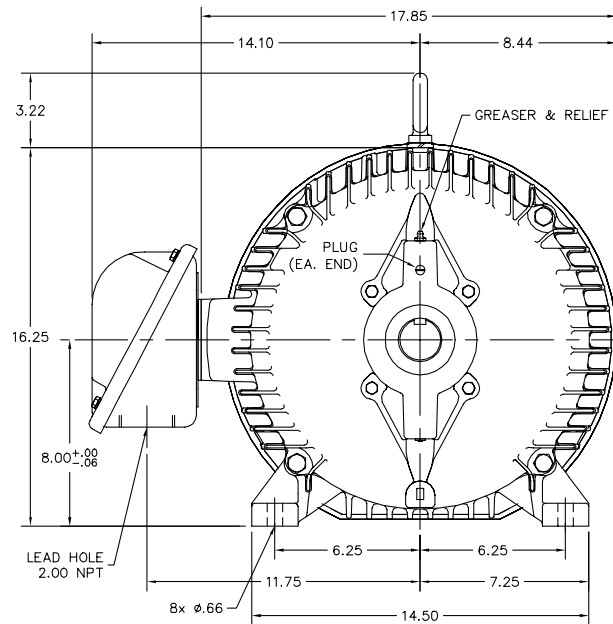
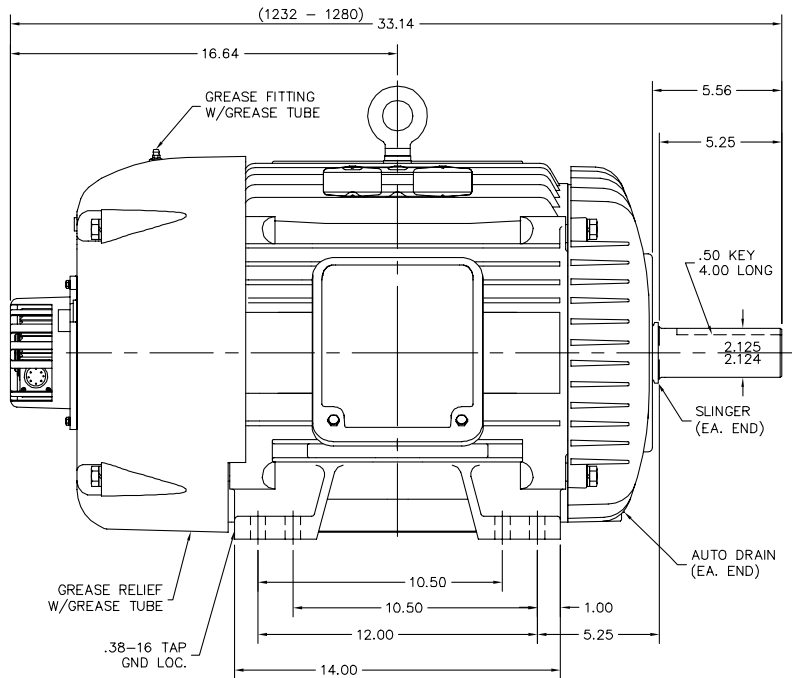

12LY6537

CUSTOMER IS RESPONSIBLE FOR DETERMINING THAT BALDOR'S PRODUCT WILL PERFORM SUITABLY IN THE INTENDED APPLICATION.

REV. DESC: ADDED GND HOLE TAP SIZE	VERSION: 02	TDR: 000000954909
REV. LTR: B	REVISD: 12:34:30 12/07/2015	BY: ENNINDO
FILE: \AAA\00193\374		
MTL: -		

**BALDOR**

HORZ TEFC 324-6T CP VECTOR W/312 BRGS, THRU SH ENC. & COVER  
SH 1 of 1

CD0180

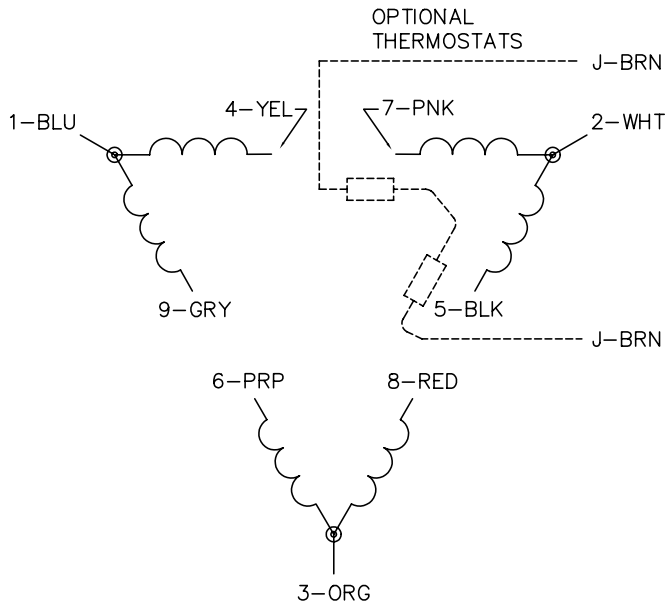

LOW VOLTAGE  
(2D)

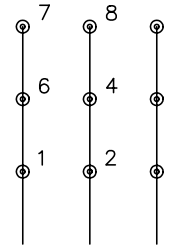

HIGH VOLTAGE  
(1D)

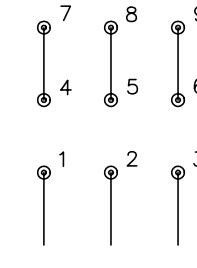

NOTES:

1. INTERCHANGE ANY TWO LINE LEADS TO REVERSE ROTATION.
2. OPTIONAL THERMOSTATS ARE PROVIDED WHEN SPECIFIED.
3. ACTUAL NUMBER OF INTERNAL PARALLEL CIRCUITS MAY BE A MULTIPLE OF THOSE SHOWN ABOVE.
4. LEAD COLORS ARE OPTIONAL. LEADS MUST ALWAYS BE NUMBERED AS SHOWN.

REV. DESC: REVISE TO SHOW OPTIONAL COLORS			
REV. LTR: C	BY: JLP	REVISED: 01/21/99 2:28	TDR: 0171435
0810D0		FILE: AAA00005148	MDL: -
		MTL: -	

**BALDOR ELECTRIC Co.**

3PH, DV, 9 LEADS, DELTA CONNECTION

CD0180

Marketing maintained PDF of MN416:

<http://www.baldor.com/support/Literature/Load.ashx/MN416?ManNumber=MN416>