

FPS

TRI-SEAL

SUBMERSIBLE PUMPS



CSA CERTIFIED
PUMP END ONLY



Drinking Water
NSF/ANSI 61

franklinwater.com



Franklin Electric

TRI-SEAL SUBMERSIBLE PUMPS

The FPS Tri-Seal 4" submersible pump features the Tri-Seal floating stage system. This new stage system improves efficiency and protects against wear when pumping abrasives. For details on how to become a registered dealer and receive a 5-year warranty, contact your local distributor.

FEATURES

- 300 Series stainless steel hub floats with the impeller maintaining a positive seal
- Phenolic washer provides downthrust protection
- Acetal impeller provides high efficiency performance and abrasion resistance
- Modified PPO diffuser and disc - proven abrasion-resistant material
- Floating stage design allows impeller to float independently
- Removable, spring-loaded check valve
- Maximum water temperature: 120 °F/49 °C
- Ceramic shaft sleeve and rubber discharge bearing protect shaft and eliminate sand wear
- Powered by Franklin Electric corrosion-resistant 4" submersible motor
- Patented impeller hub seal system seals radially and axially to prevent fluid recirculation, providing high performance in the harshest conditions

No.	Component
1	Phenolic washer provides axial sealing as impeller floats in the stage
2	Stainless steel hub seal is captured but not stationary, floating with the impeller for maximum sealing
3	Stainless steel impeller eye seal

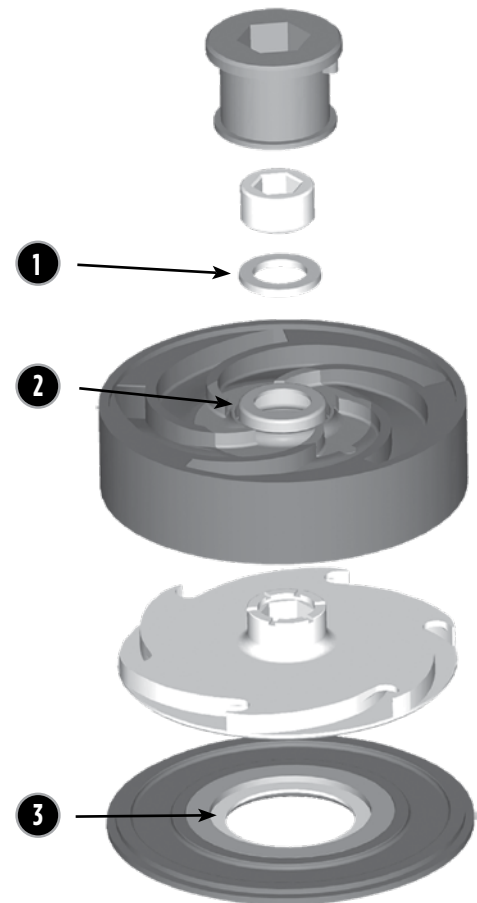

**Patented TRI-SEAL™
Floating Stage System**
U.S. Patent No. 7,290,984