

Please read and save these instructions. Read carefully before attempting to assemble, install, operate or maintain the product described. Protect yourself and others by observing all safety information. Failure to comply with instructions could result in personal injury and/or property damage! Retain instructions for future reference.

# Piston Drum Pump

## Stainless Steel Model

### Description

This drum pump handles many water base solutions, acids & corrosives, kersoene, light oils, detergents, waxes, disinfectants, gasoline, diesel fuel, Xylele, Freon, Acetone, and other liquids which are compatible with pump component materials\*. The pump is supplied with a 2 inch bung adapter and fits most 5, 6, 30, 45, and 55 gallon drums.

(\* Always refer to a chemical resistance chart to confirm compatibility. Not rated for food products. Do not use for free chlorine.

### Unpacking

When unpacking the unit, thoroughly inspect for any damage that may have occurred during transit.

Check for loose parts, missing parts or damaged parts. Transit damage claims should be made to the shipping company.

### Specifications

Flow . . . . . 8 oz. Per up-stroke  
 Maximum liquid temperature . . . 200° F  
 Mounting. . . . . 2" Bung adapter  
 Inlet. . . . . 1/2" I.D.  
 Outlet . . . . . 3/8" I.D.  
 Bung adapter. . . . . Polypropylene  
 Suction tube . . . . . Teflon  
 Pump Body . . . . . 304 SS  
 Seals & Gaskets . . . . . Teflon  
 Valve. . . . . Glass  
 Weight. . . . . 3 lbs.  
 SS Stainless Steel

### General Safety Information

**⚠ WARNING** *It is the responsibility of the user to operate the pump in conformance with OSHA rules for dispensing liquids. Pump containers should be grounded when using with flammable liquids to avoid static electricity. Pump should be washed out before usage since processing lubricants could contaminate the fluid.*

1. When using a hand pump (especially when pumping flammable, combustible or hazardous liquids) follow all electrical and safety codes, as well as the United States Occupational Safety and Health Act (OSHA), most recent National Electrical Code (NEC), National Fire Protection Association, Inc.\* (NFPA) Code 30 (Flammable and Combustible Code), NFPA 56 A (Standard for use of Inhalation Anesthetics), NFPA 77 (Static Electricity), NFPA 78 (Lighting Protection Code), NFPA 80 (Standard for Fire Doors and Windows), NFPA 251 (Standard Method of Fire Test of Building Construction), NFPA 704 (Identification of the Fire Hazards of Materials), other NFPA codes, local codes and ordinances, as needed in a particular application.

(\*Any of the NFPA Codes can be obtained from: National Fire Protection Association, Inc., 1 Battertymarch Park, Quincy, MA 02269, telephone 1-800-344-3555. Write or call for listing and prices.

2. Know the pump application, limitations, and potential hazards. The "WARNING" statements indicate potentially hazardous conditions for the operator or equipment. TAKE NECESSARY STEPS TO PROTECT PERSONNEL AND EQUIPMENT.

Pump should only be used with liquids compatible with pump component materials. Consult PUMP CHEMICAL COMPATIBILITY CHART and PUMP SPECIFICATIONS. Also, the chemical supplier should be consulted regarding any questions of chemical compatibility, proper and safe use and handling of chemicals.

Misapplication of pump or use of incompatible liquids will void warranty.

**⚠ WARNING** *In order to properly use this product familiarize yourself with this pump and also with the liquid (chemical, etc.) that is going to be pumped through the unit. Although this pump is suitable for many liquids, it is not suitable for all liquids!*

3. Pumping hazardous, flammable, or combustible liquids, should only be done in buildings, rooms, or areas suited for this purpose. (See NFPA 30, NFPA 78, NFPA 80, NFPA 251, NFPA 704, other suitable NFPA codes, OSHA, insurance companies, local codes and ordinances.)

**⚠ WARNING** *When filling cans, drums, etc. with combustible or flammable liquids, both container pumping from and container pumping to, should be bonded and grounded to dissipate possible accumulations of static electricity, and minimize sparks caused by static electricity (refer to NFPA 77 for specifics and further details).*

**⚠ WARNING** *Removal of outer garments in work areas where there may be flammable or explosive liquids, which are ignitable with low electrical energy, can be fatal and/or cause property damage (refer to NFPA 56A and NFPA 77 for further details).*

4. The "WARNING" and instructions for

# Piston Drum Pump

## Stainless Steel Model

### General Safety Information (Continued)

gasoline below pertain not only to gasoline, but to any flammable, combustible or hazardous fluid.

**⚠ WARNING** *Gasoline is a highly flammable fuel.*

*The improper use, handling, or storage of gasoline can be dangerous. Prevent accidents by following these safety rules:*

- a. Use gasoline only as fuel, never as a cleaning fluid.
- b. Use only an approved container to hold or store gasoline. Never store gasoline in familiar containers such as milk containers or soda pop bottles.
- c. Store gasoline in a cool location, out of the reach of children. Never store gasoline near heat or an open flame.
- d. Provide a fire extinguisher nearby when working with gasoline. Be sure extinguisher is in operating condition-check the pressure gauge or indication. Be familiar with its proper use. Consult local fire department for the correct type of extinguisher for your application. Extinguishers rated ABC by the National Fire Protection Association are appropriate for most applications.
- e. Provide positive shut-off valves on all permanent fuel supplies. Fuel lines must be of steel piping, adequately secured, and free from leaks.
- f. Provide adequate ventilation, and clean up any spills when handling or pumping flammable liquids.
- g. **POSITIVELY NO SMOKING!**
5. Do not use torches or apply fire or flame to this pump for any reason.
6. Secure the discharge line before starting the pump. An unsecured

discharge line will slip, possibly causing personal injury and/or property damage.

7. Do not overtighten threaded fittings. One full turn past hand tight is usually enough to prevent leakage. Teflon sealant tape is provided and should be used on all threaded joints, including the spout.
8. Check hoses for weak or worn condition before each use, making certain that all connections are secure.
9. Periodically inspect pump and system components. Perform routine maintenance as required.
10. Drain all liquids from the system before servicing.

**⚠ WARNING** *Any pump used to transfer flammable liquids must be stored in a well ventilated area after use.*

11. Personal Safety:
  - a. Wear safety glasses at all times when working with pump.
  - b. Wear a face shield, proper apparel and suitable respiratory equipment when pumping hazardous chemicals.
  - c. Keep work area clean, uncluttered, and properly lighted. Replace all unused tools and equipment.
  - d. Keep visitors at a safe distance from the work area.
  - e. Make workshop childproof with padlocks, master switches, and by removing starter keys.

**⚠ WARNING** *Failure to follow all General Safety Information can result in a fatality, personal injury and/or property damage!*

### Assembly and Installation

1. Slip tubing (Ref. No. 4) and clamp (Ref. No. 3) over the barb connector (Ref. No. 2) on the inlet end of the pump. Tighten clamp. To assure

priming of this pump the clamp must be tight to prevent air from leaking between the tubing and barb connector.

2. Lower pump assembly through bung adapter (Ref. No. 1) to desired depth. Tighten butterfly screw to hold unit in place. **DO NOT** use wrench or tool to tighten butterfly screw.

### Operation

1. Grasp handle and stroke plunger in and out of pump casing. This will prime pump.
2. To prevent siphoning after use, plunger/handle should be set in down position.

### Maintenance

**IMPORTANT:** Periodically inspect the pump assembly and suction tubes for weak or worn condition. Make certain that all connections and fasteners are tight and secure. Perform routine maintenance as required.

# Models 4840-98

## Troubleshooting Chart

| Symptom  | Possible Cause(s)  | Corrective Action  |
|--|--|--|
| Pump does not prime<br><b>NOTE:</b> For stubborn liquids, try filling pump through discharge port before operation. A filled casing primes quickly | 1. Suction line above liquid   | 1. Ensure that open end of suction line remains completely below surface of liquid   |
|  | 2. Pump speed too slow   | 2. Operate pump handle rapidly until pump primes (up to 30 cycles)   |
|  | * 3. Unsuitable suction line   | 3. Pumps are intended for use with suction line supplied. Longer or collapsible suction line may prohibit priming. Use short length rigid line similar in diameter to suction port. (Maximum pump height above liquid 36")   |
|  | 4. Clogged suction line and/or filter                                      | 4. Clean suction line and/or filter (where applicable)   |
|  | 5. Suction line air leakage  | 5. Verify that all suction line connections are sealed tightly. Use Teflon® tape or appropriate sealant if necessary   |
|  | 6. Cover air leakage   | 6. Inspect pump cover(s) for looseness and damaged or slipped gaskets. Replace damaged gaskets and snug-up cover(s)  |
|  | 7. Shaft air leakage   | 7. Verify shaft seal is properly seated and in good condition. Replace seal if worn or damaged   |
|  | 8. Housing air leakage   | 8. Inspect entire pump housing, cover(s), and shaft for cracks. Replace damaged parts  |
|  | Δ 9. Shifted or worn rotor   | 9. Loosen all cover bolts. View pump from side with suction/discharge ports in vertical position and on right hand side. Reposition rotor by grasping covers and sliding towards 3 o'clock position. Do not use excessive force. Hold in position and re-tighten cover bolts                                       |
|  | 10. Damaged/worn pump parts  | 10. Remove pump cover and inspect for broken pieces. Components should have smooth finish, no large grooves or voids. Replace damaged parts. Piston type pumps may include a poppet valve which is designed to prevent back-flow. If excessive leakage past valve is found, replace valve (some leakage is normal) |
| Handle difficult or impossible to move   | 1. Pump has not been used for some time                                    | 1. Remove pump cover and inspect for crystallized, solidified, or gummy remains. Clean parts. To prevent future occurrences, flush pump with appropriate solvent after pumping problem liquid  |
|  | 2. Damaged/worn pump parts   | 2. Remove pump cover and inspect internal parts. Components should have smooth finish, no large grooves or voids. Replace damaged parts  |
|  | 3. Corroded pump parts   | 3. Remove pump cover and inspect for corrosion. Clean parts and use pump only for liquids which are compatible with pump component materials   |
|  | † 4. Damaged/worn gear drive parts   | 4. a) Remove oil plug from gear case and verify oil level is correct, top-up if necessary. See "Maintenance" for proper lubricant<br>b) If pump is still difficult to turn, drain gear oil and inspect oil for contaminants indicating damaged gears. Replace damaged parts  |
| Insufficient flow  | 1. Clogged, collapsed, or undersized filter, suction and/or discharge line | 1. Pumps are intended for use with supplied rigid line and filter (where applicable). Verify line and filter are clean, not pinched closed, and of similar size of port connection   |
|  | 2. Also see above "Pump does not prime"                                    | 2. Check and repair as necessary   |

(\*) For pumps supplied without suction/discharge lines, see "Description" for appropriate line.

(Δ) Applies only to vane (not lobe or piston) type pumps.

(†) Applies only to lobe (not vane or piston) type pumps, which use a gear drive unit.

***For Repair Parts, contact dealer where pump was purchased.***

Please provide following information:

- Model number
- Serial number (if any)
- Part description and number as shown in parts list

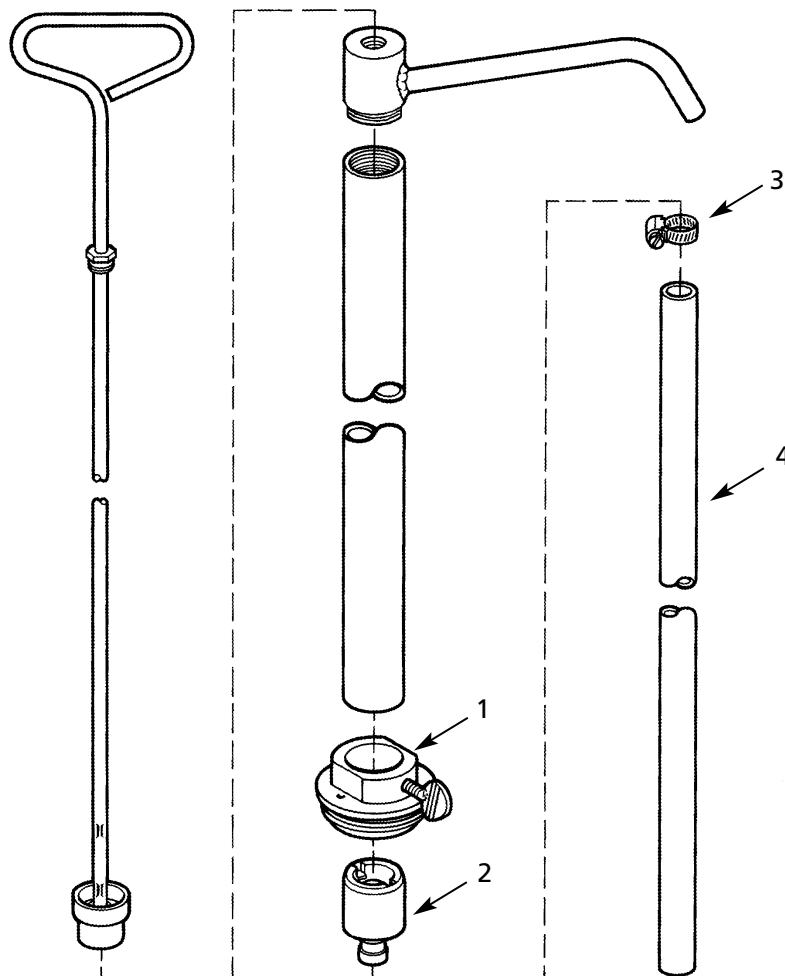

Figure 1 - Repair Parts Illustration

**Repair Parts List**

| Reference Number | Description                    | Part Number | Quantity |
|------------------|--------------------------------|-------------|----------|
| 1                | Bung Adapter w/Butterfly Screw | 4840-170-00 | 1        |
| 2                | Poppet Valve Assembly          | 4840-070-00 | 1        |
| 3                | Hose Clamp 5/16" to 7/8" SS    | *           | 1        |
| 4                | Inlet Tube                     | 4840-171-00 | 1        |

(\*) Standard hardware item, available locally.  
 (SS) Stainless steel.