

# Performance Data

S3S/S4S/ &  
SB3S/SB4S

Wholesale Products Page: 6520-1

Section: Performance Data

Dated: January 2001

RPM: **1570**

Discharge: **2"**

Solids: **2"**

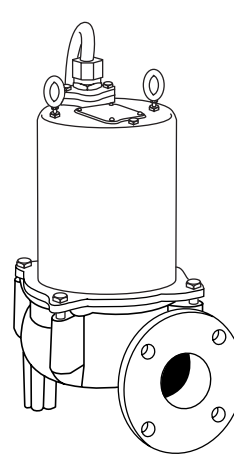

**S3S**

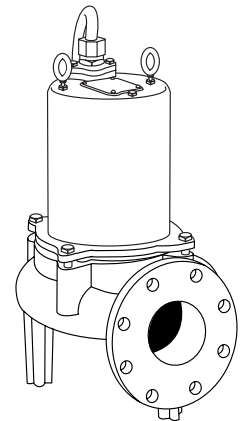

**S4S**

**MODEL NO. S3S & SB3S**

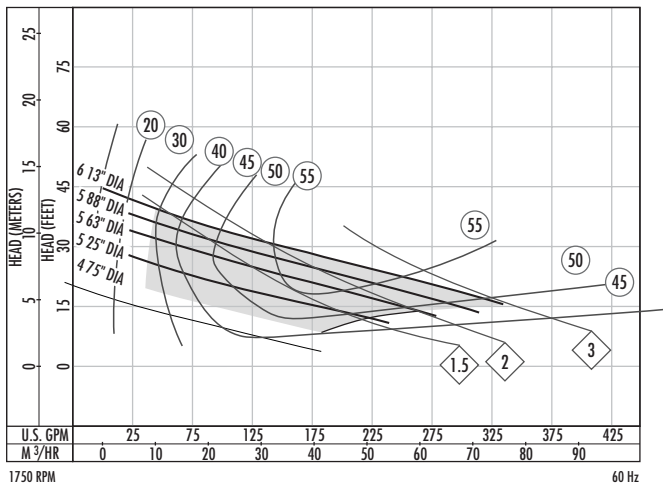

**MODEL NO. S4S & SB4S**

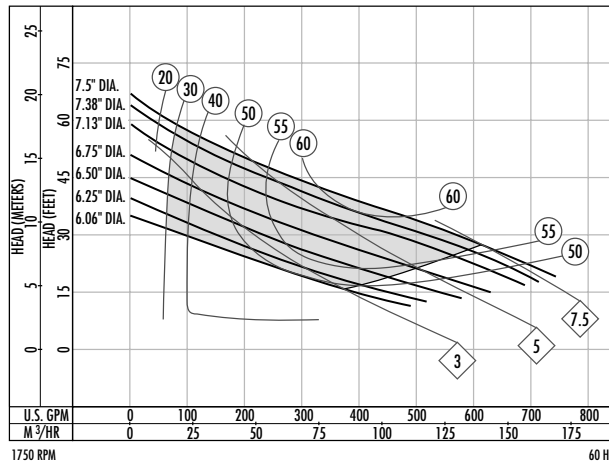

The curves reflect maximum performance characteristics without exceeding full load (Nameplate) horsepower. All pumps have a service factor of 1.2. Operation is recommended in the bounded area with operational point within the curve limit. Performance curves are based on actual tests with clear water at 70° F. and 1280 feet site elevation.

Conditions of Service:

GPM: \_\_\_\_\_ TDH: \_\_\_\_\_



**THIS PAGE LEFT INTENTIONALLY BLANK**

All dimensions in inches. Metric for international use. Component dimensions may vary  $\pm 1/8$  inch. Dimensional data not for construction purpose unless certified. Dimensions and weights are approximate. On/Off level adjustable. We reserve the right to make revisions to our product (s) and the product (s) specifications without notice.

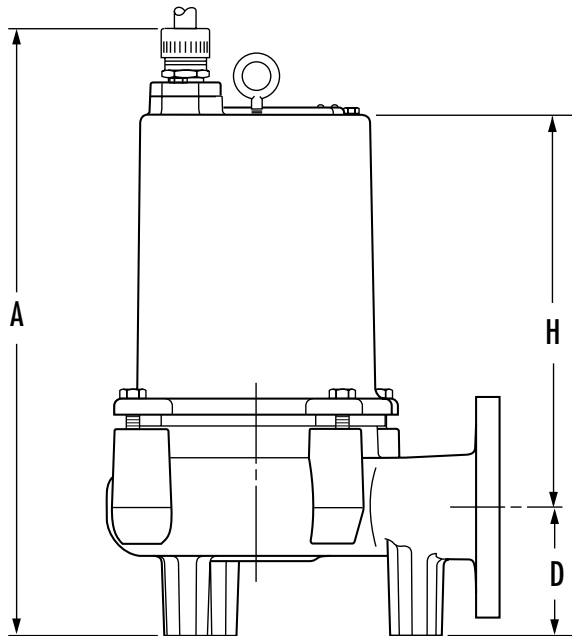
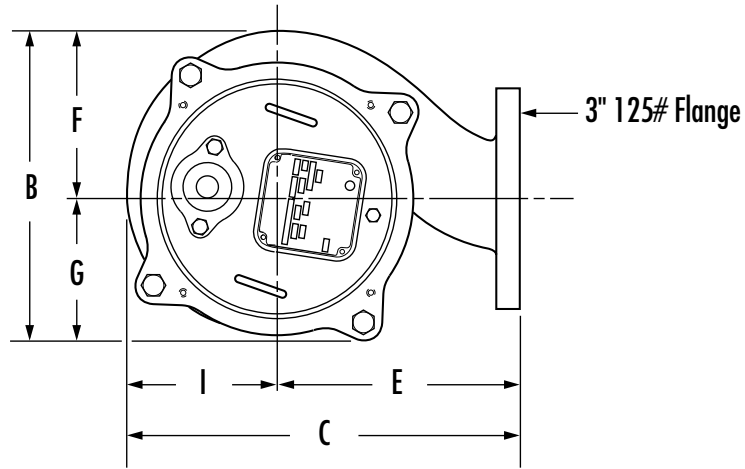

	<b>A</b>	<b>B</b>	<b>C</b>	<b>D</b>	<b>E</b>	<b>F</b>	<b>G</b>	<b>H</b>	<b>I</b>
<b>S3S</b>	20-5/8	10-1/2	13-3/8	4-3/8	8-1/4	5-5/8	4-7/8	13-3/8	5-1/8

ALL DIMENSIONS IN INCHES  
NOTE: CASTING DIMENSIONS MAY VARY ± 1/8"

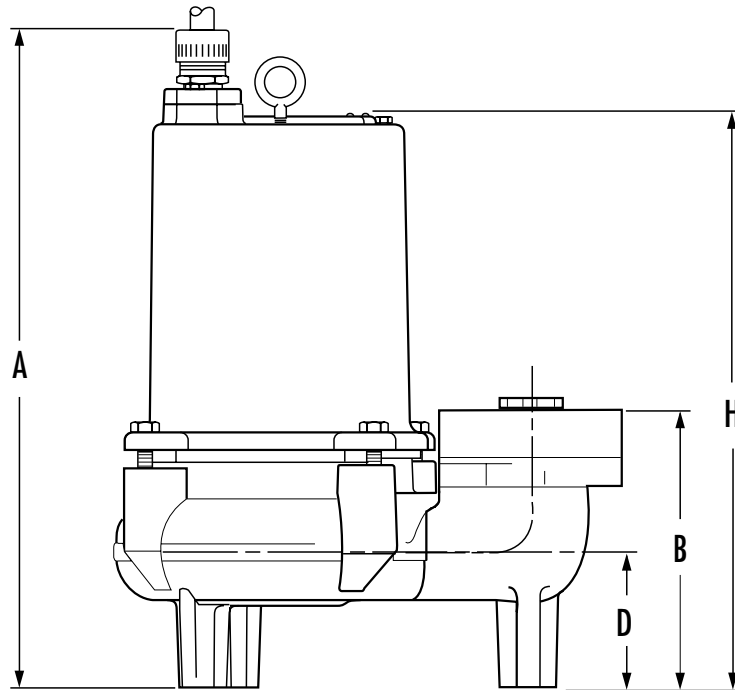
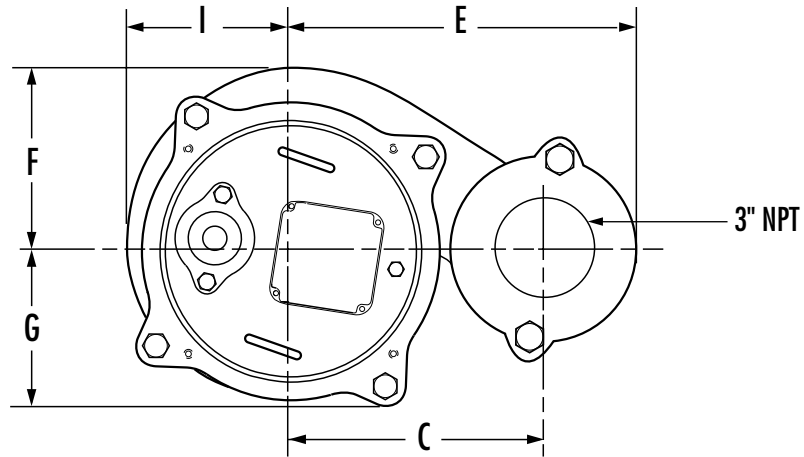

	<b>A</b>	<b>B</b>	<b>C</b>	<b>D</b>	<b>E</b>	<b>F</b>	<b>G</b>	<b>H</b>	<b>I</b>
<b>SB3S</b>	20-5/8	8-3/4	7-7/8	4-3/8	10-11/16	5-13/16	4-13/16	18-1/16	5-7/32

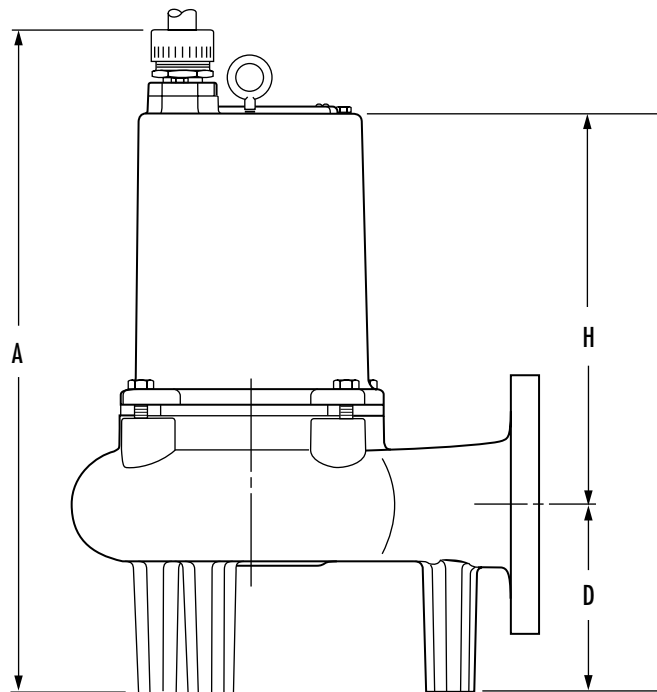
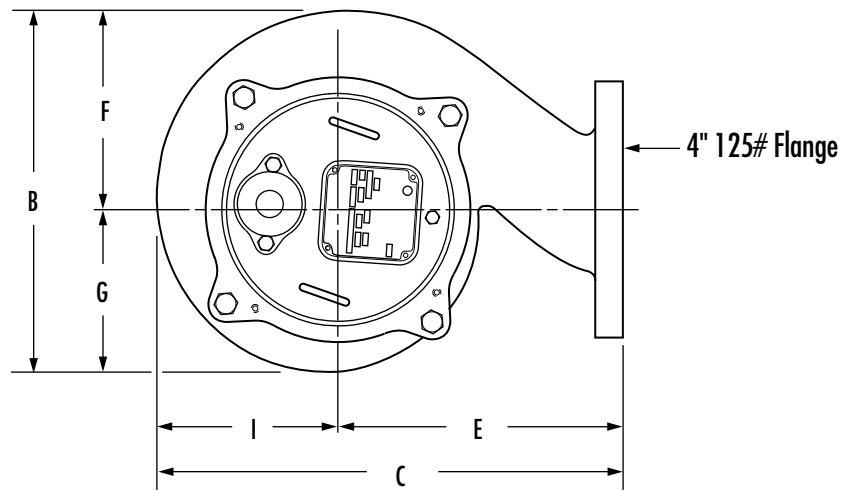

	<b>A</b>	<b>B</b>	<b>C</b>	<b>D</b>	<b>E</b>	<b>F</b>	<b>G</b>	<b>H</b>	<b>I</b>
<b>S4S</b>	23-1/8	12-3/4	16-3/8	6-1/2	10	7	5-3/4	20-3/16	6-3/8

ALL DIMENSIONS IN INCHES  
NOTE: CASTING DIMENSIONS MAY VARY ± 1/8"

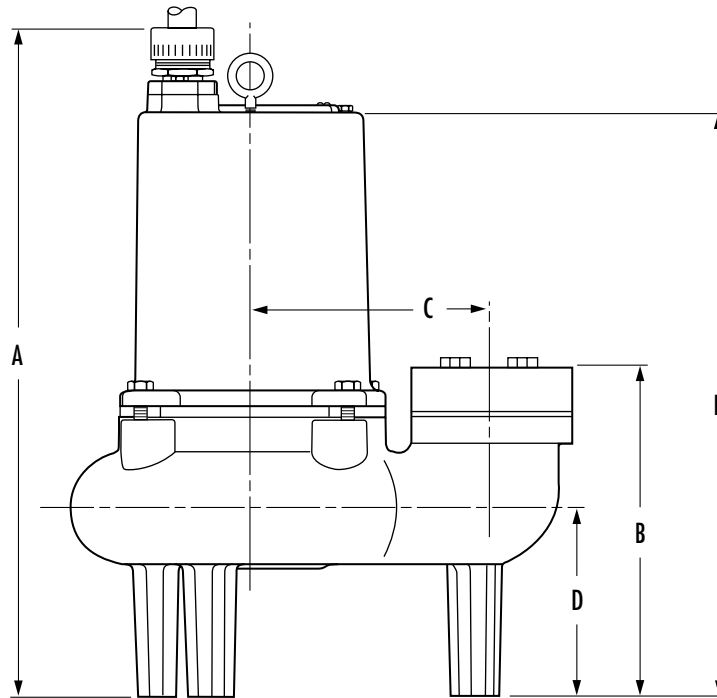
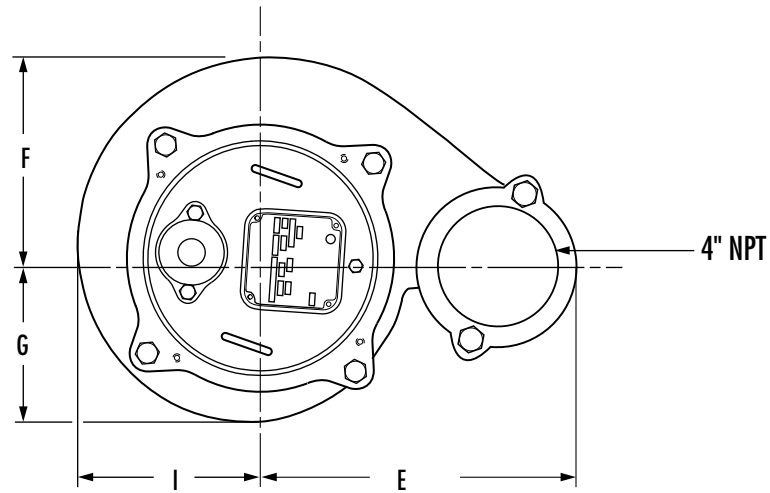

	<b>A</b>	<b>B</b>	<b>C</b>	<b>D</b>	<b>E</b>	<b>F</b>	<b>G</b>	<b>H</b>	<b>I</b>
<b>SB4S</b>	23-1/8	11-3/8	8-5/16	6-1/2	11-1/8	7-1/16	5-13/16	20-3/16	6-1/2

### MODEL: S3S/SB3S & S4S/SB4S — Sewage Pump

R.P.M.	1750
MOTOR TYPE	ENCLOSED, OIL COOLED INDUCTION, VFD SUITABLE
MOTOR DESIGN NEMA TYPE	B (3 $\phi$ ) L (1 $\phi$ )
GENERAL INSULATION CLASS	F
STATOR WINDING CLASS	F
MAXIMUM STATOR TEMPERATURE	311°F
MOTOR PROTECTION	N/A
VOLTAGE TOLERANCE	±10%

HP	VOLTAGE	PHASE	NEC CODE	SF	FULL LOAD AMPS	RUN KW	START AMPS	START KVA	RUN KVA	MTR. EFF. 100% FL	MTR. EFF. 75% FL	MTR. EFF. 50% FL	PMR. FACT. 100% FL	PMR. FACT. 75% FL	PMR. FACT. 50% FL
1.5	230	1	L	1.2	12.8	1.9	62	14.3	2.5	.60	.56	.48	.75	.68	.60
	200	3	P	1.2	6.6	1.6	46	15.9	2.3	.70	.65	.56	.70	.62	.52
	230				5.8	1.6	40	15.9	2.3						
	460				2.9	1.6	20	15.9	2.3						
575	2.3	1.6	16	15.9	2.3										
2.0	230	1	L	1.2	12.8	1.9	62	14.3	2.5	.60	.56	.48	.75	.68	.60
	200	3	L	1.2	6.6	1.6	46	15.9	2.3	.70	.65	.56	.70	.62	.52
	230				5.8	1.6	40	15.9	2.3						
	460				2.9	1.6	20	15.9	2.3						
575	2.3	1.6	16	15.9	2.3										
3.0	230	1	J	1.2	20.0	3.9	62	14.3	4.6	.58	.60	.57	.84	.81	.70
	200	3	J	1.2	10.9	3.1	64.5	22.3	3.8	.72	.70	.64	.82	.80	.72
	230				9.5	3.1	56	22.3	3.8						
	460				4.8	3.1	28	22.3	3.8						
575	3.8	3.1	22.5	22.3	3.8										
5.0	200	1	G	1.2	29.5	5.7	125	28.8	6.8	.66	.65	.60	.84	.77	.64
	200	3	L	1.2	17.6	4.8	108	37.4	6.1	.79	.77	.72	.78	.73	.62
	230				15.3	4.8	94	37.4	6.1						
	460				7.6	4.8	47	37.4	6.1						
575	6.1	4.8	37.6	37.4	6.1										
7.5	200	3	K	1.2	29.0	7.2	194	67.0	10.1	.78	.76	.71	.72	.66	.56
	230				25.2	7.2	168	67.0	10.1						
	460				12.6	7.2	84	67.0	10.1						
	575	10.1	7.2	67.2	67.0	10.1									

**THIS PAGE LEFT INTENTIONALLY BLANK**



**MODEL: S3S/SB3S — Standard Single Seal Sewage Ejector Pumps****Physical Data:**

DISCHARGE SIZE	3"
SOLIDS SIZE	2-1/2"
IMPELLER TYPE	BALANCED, SEMI OPEN, 2 VANE
CABLE LENGTH	30' STANDARD
PAINT	PAINTED AFTER ASSEMBLY. DARK GREEN, WATER REDUCIBLE ENAMEL, ONE COAT, AIR DRIED.

**Temperature:**

MAXIMUM LIQUID	140°F
MAXIMUM STATOR	311°F
OIL FLASH POINT	390°F
HEAT SENSOR	Open: 257°F MAX./239°F MIN. Closed: 194°F MAX./119°F MIN.

**Technical Data:**

POWER CORD TYPE	STW-A WATER RESISTANT 600V, 60°C	
MATERIALS OF CONSTRUCTION	MOTOR HOUSING	CAST IRON ASTM A-48 CLASS 30
	CASING	CAST IRON ASTM A-48 CLASS 30
	IMPELLER	CAST IRON ASTM A-48 CLASS 30
	MOTOR SHAFT	400 STAINLESS STEEL
	HARDWARE	300 SERIES STAINLESS STEEL
	"O" RINGS	BUNA N
MECHANICAL SEALS Standard:	CARBON/CERAMIC, TYPE 21, BF1C1	
UPPER BEARING	(RADIAL) SINGLE ROW — BALL	
LOWER BEARING	(THRUST) SINGLE ROW — BALL	

**MODEL: S4S/SB4S — Standard Single Seal Sewage Ejector Pumps**
**Physical Data:**

DISCHARGE SIZE	4"
SOLIDS SIZE	3"
IMPELLER TYPE	BALANCED, SEMI OPEN, 2 VANE
CABLE LENGTH	15' STANDARD 30' OPTIONAL
PAINT	PAINTED AFTER ASSEMBLY. DARK GREEN, WATER REDUCIBLE ENAMEL, ONE COAT, AIR DRIED.

**Temperature:**

MAXIMUM LIQUID	140°F
MAXIMUM STATOR	311°F
OIL FLASH POINT	390°F
HEAT SENSOR	Open: 257°F MAX./239°F MIN. Closed: 194°F MAX./119°F MIN.

**Technical Data:**

POWER CORD TYPE	STW-A WATER RESISTANT 600V, 60°C	
MATERIALS OF CONSTRUCTION	MOTOR HOUSING	CAST IRON ASTM A-48 CLASS 30
	CASING	CAST IRON ASTM A-48 CLASS 30
	IMPELLER	CAST IRON ASTM A-48 CLASS 30
	MOTOR SHAFT	400 STAINLESS STEEL
	HARDWARE	300 SERIES STAINLESS STEEL
	"O" RINGS	BUNA N
MECHANICAL SEALS Standard:	CARBON/CERAMIC, TYPE 21, BF1C1	
UPPER BEARING	(RADIAL) SINGLE ROW — BALL	
LOWER BEARING	(THRUST) SINGLE ROW — BALL	

**MODELS: S3S/S4S & SB3S/SB4S, Sewage Pumps****1.01 GENERAL**

Contractor shall furnish all labor, materials, equipment and incidentals required to provide (Qty.) submersible centrifugal non clog sewage pump(s) as specified herein. The pump models covered in this specification are the S3S/S4S and SB3S/SB4S. The pump furnished for this application shall be MODEL \_\_\_\_\_ as manufactured by Hydromatic Pump.

**2.01 DESIGN CONDITIONS**

Each pump shall be rated \_\_\_\_\_ H.P., \_\_\_\_\_ volts, \_\_\_\_\_ phase, \_\_\_\_\_ hertz and operate at \_\_\_\_\_ RPM.

**3.01 OPERATING CONDITIONS**

The pump shall deliver \_\_\_\_\_ U.S. GPM/LPS at \_\_\_\_\_ feet/meters TDH., and handle a \_\_\_\_\_ inch solid. The curve submitted for approval shall state, in addition to head and capacity performance, solid handling capability, amp rating, and design impeller diameter.

**4.01 CONSTRUCTION**

Each pump shall be of the sealed submersible type, incorporating features normally found in pumps furnished for the heavy duty industrial or municipal markets.

These features include:

1. The seal housing for the S3S/S4S and SB3S/SB4S is corrosion resistant high density thermoplastic.
2. The pump inlet shall be open and clear, without screening to provide access for sewage and solids.
3. All external mating parts shall be machined and Buna N, O-Ring sealed.
4. All fasteners exposed to the pumped liquid shall be 300 series stainless steel.
5. All power cords shall be water resistant UL or CSA approved, with double insulation, and sized as a function of Amp. draw.

**5.01 MOTOR AND SHAFT:** The stator, rotor and bearings shall be mounted in a sealed submersible type housing. Single phase motors shall be split phase or capacitor start with centrifugal switch. Three phase motors shall be Polyphase. Full Load and Locked Rotor Amps. as well as Start and Run winding resistance shall be tabulated for each pump.

**6.01 BEARINGS, SHAFT AND MECHANICAL SEAL**

An upper radial and lower thrust bearing shall be required. These shall be heavy duty single row ball bearings which are permanently and continuously lubricated and cooled by the dielectric oil which fills the motor housing. The motor shaft shall be stainless steel and sealed from the pumped liquid with a carbon ceramic mechanical seal.

**7.01 IMPELLER**

The Impeller shall be high capacity, two vane, non clog design with pump out vanes on the back side. These vanes wash out grit and stringy material that will damage the shaft and mechanical seal.

**8.01 AUTOMATIC CONTROL**

All single phase pumps should be capable of automatic operation.

**9.01 PRESSURE SWITCH**

The Single Phase pumps are furnished with a pressure diaphragm switch that features a piggy-back plug that allows the pump to be operated manually without removal from the sump.

**10.01 FLOAT SWITCH**

The Single Phase pump is supplied with a tilt-sensitive wide-angle float switch is sealed in a non-corrosive PVC enclosure. The unit is UL listed for water and sewage and CSA certified. The float switch shall also be fitted with a piggy-back plug that allows the pump to be operated manually without removal from the sump.

**11.01 MANUAL CONTROL**

The Single Phase pumps are not supplied with any type of automatic control. A super or double wide angle piggy-back float switch can be supplied and fitted to these pumps.

**12.01 PAINTING**

All cast iron parts shall be painted before assembly with a water reducible alkyd air dried enamel. The paint shall be applied in one coat with a minimum thickness of 3 to 4 mils.

**13.01 TESTING**

All pumps shall be individually tested to include the following:

1. The pump and power cord shall be visually inspected for imperfections, cuts or nicks.
2. The pump shall have a ground continuity check and the motor chamber shall be Hi-potted to test for moisture content and/or insulation defects.
3. The motor and volute housing shall be pressurized and a 10 second air leak decay test run.
4. Oil is added, and the pump is run. Voltage and current are monitored visually, electronically, and the tester listens for any noise or malfunction.