

# VIP-XR

## 3 Phase Duplex Pump Control Panel (Level Transmitter Based) Quick Start Guide

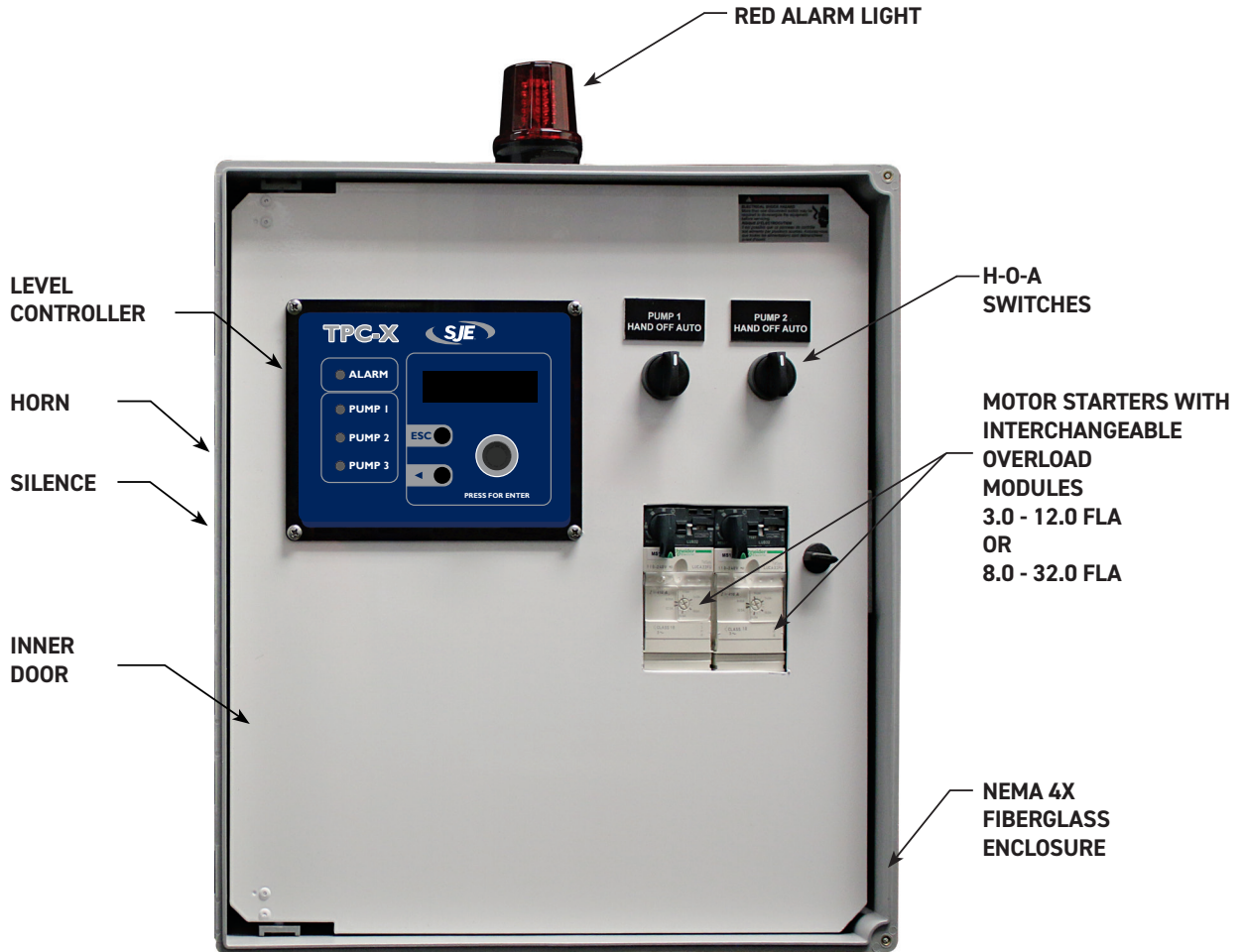

	<b>WARNING!</b> <b>AVERTISSEMENT!</b> <b>ADVERTENCIA!</b>	
<b>ARC FLASH &amp; SHOCK HAZARD</b> Appropriate PPE required. More than one disconnect switch may be required to de-energize the equipment before servicing.		
<b>RISQUE D'ARC ÉLECTRIQUE ET DE CHOC</b> EPI adéquat requis. Il est possible que ce panneau de contrôle soit alimenté par plusieurs sources. Assurez-vous que toutes les alimentations sont débranchées avant d'ouvrir.		
<b>RIESGO DE ARCO ELÉCTRICO Y ELECTROCUCIÓN</b> Se requiere equipo de protección personal adecuado. Más de un interruptor de desconexión se puede requerir o necesitar para poder desenergizar el equipo antes de proceder con algún tipo de servicio o mantenimiento.		

This control panel must be installed and serviced by a licensed electrician in accordance with the National Electric Code NFPA-70, state and local electrical codes.

All conduit running from the tank to the control panel must be sealed with conduit sealant to prevent moisture or gases from entering the panel. NEMA 4X enclosures are for indoor or outdoor use, primarily to provide a degree of protection against corrosion, windblown dust and rain, splashing water and hose-directed water. **Cable connectors must be liquid-tight in NEMA 4X enclosures.**

Check the incoming power: voltage, amperage, and phase to meet requirements of the pump motor being installed. Always check the pump nameplate for electrical requirements.

# INSTALLATION INSTRUCTIONS

Dimensions: 18" x 16" x 10"

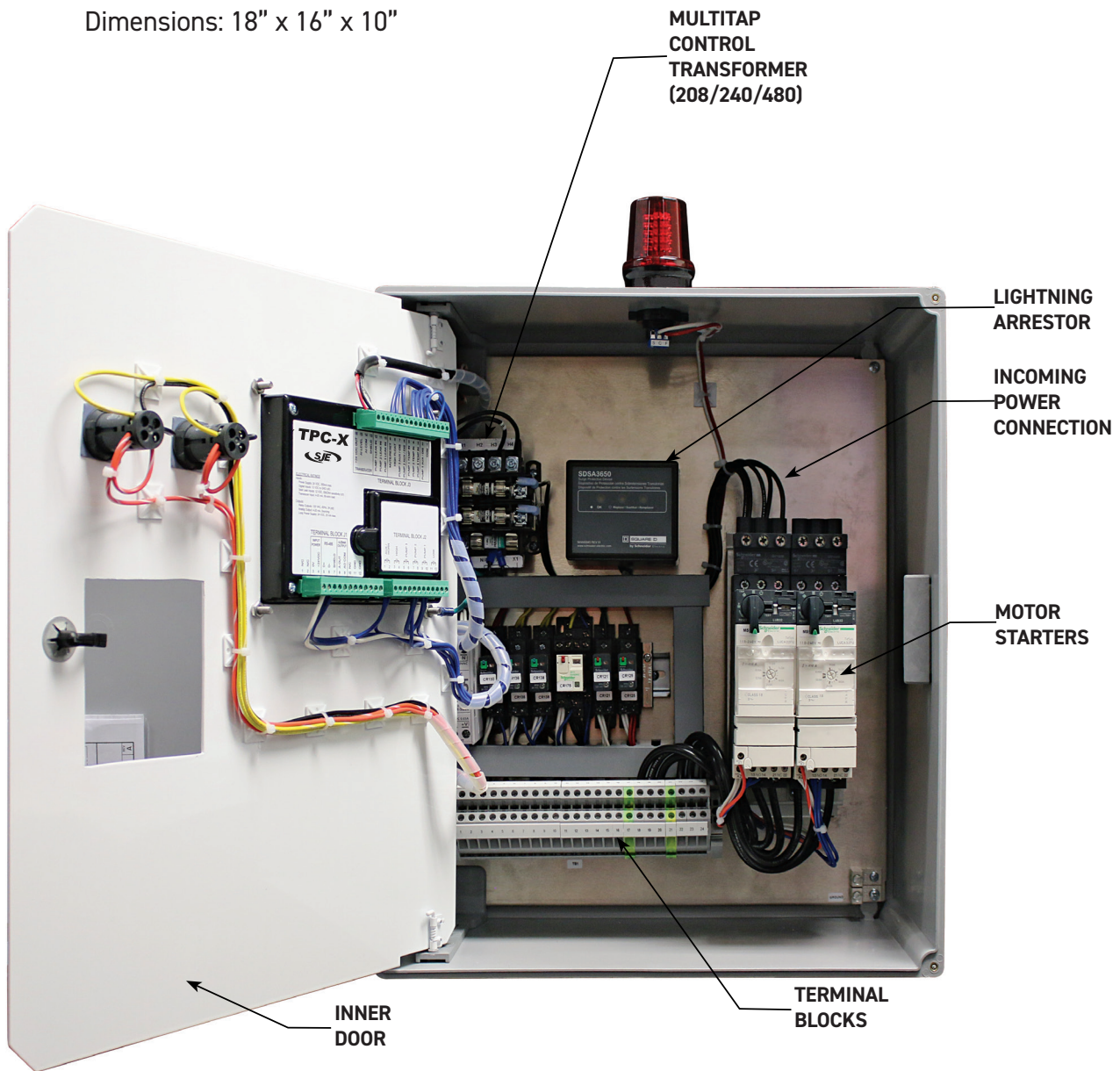

1. With power disconnected, insert the appropriate overload modules in the motor starters.

**These overload modules must be ordered separately.  
The control panel will not operate without overload modules.**

- a) Adjust the dials to match motor full load amps.
- b) Turn motor starter switch to the ON position.

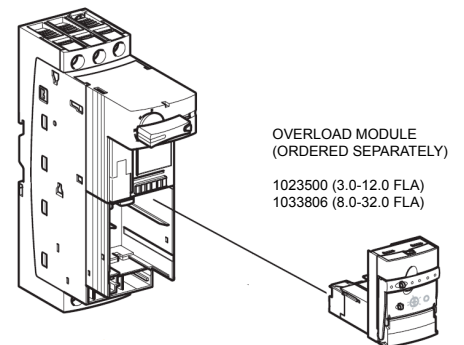

2. Connect pump power wires and sensors to terminal blocks as indicated on the provided electrical schematics below.
3. Connect incoming power (208/230/460 VAC, 3 phase) to the terminal block as indicated below. Connect the labeled wire on the transformer primary to match the incoming voltage.

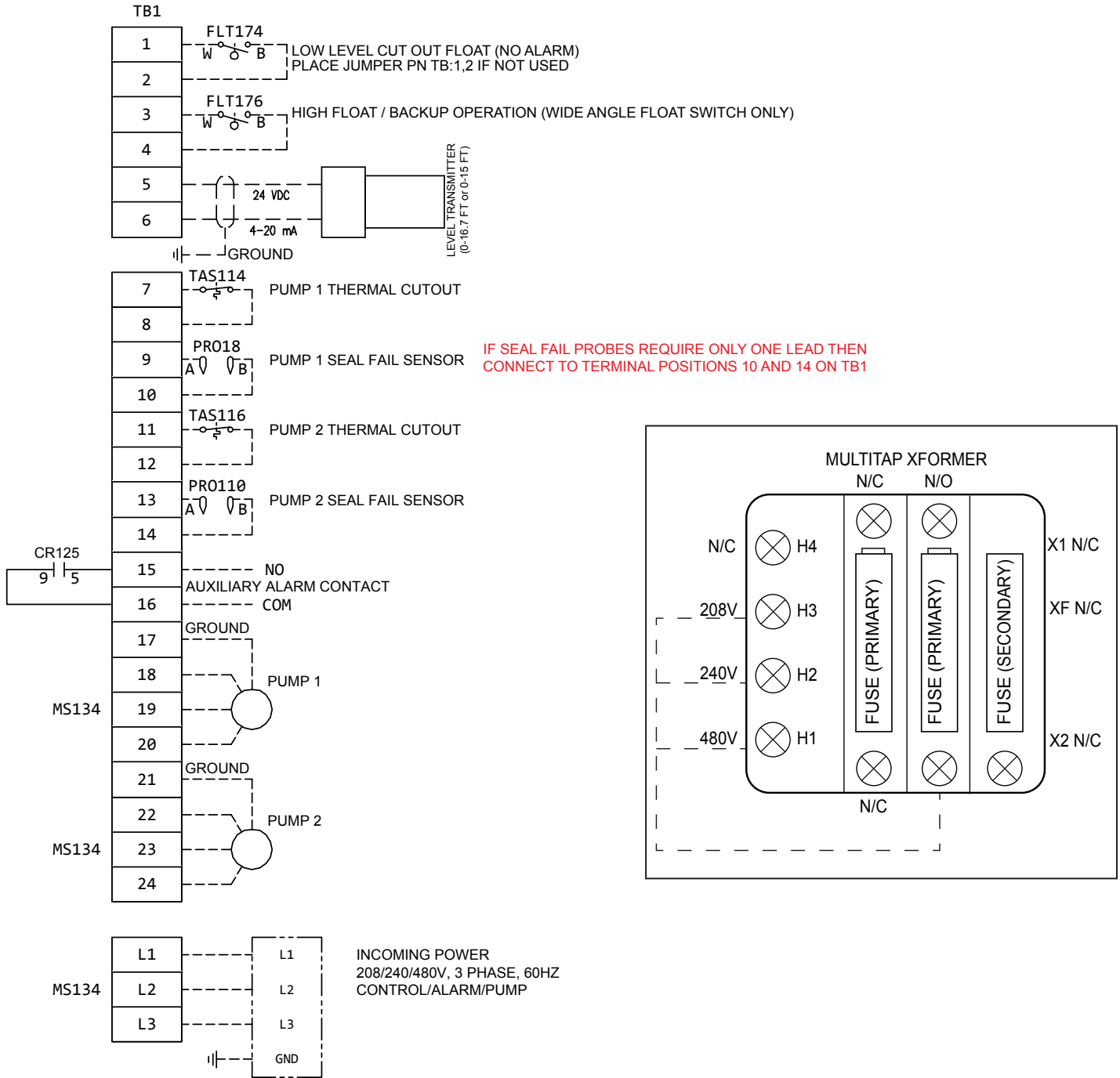

## **TRANSMITTER OPERATION (IN AUTO MODE)**

As the liquid level rises above the LEAD PUMP OFF set point the pumps will remain inactive. As the level rises above the LEAD PUMP ON set point, the lead pump will start and remain ON until the level drops below the LEAD PUMP OFF level. If the level continues to rise past the LEAD PUMP ON and above the LAG PUMP ON set point, the second pump will start and both pumps will remain ON until the level drops below the LAG PUMP OFF set point.

## **HIGH LEVEL BACK UP FLOAT (IN AUTO MODE)**

Use a wide angle high level float switch as a transmitter and controller back up. When the float is up, both pumps will run. If the controller is still working, the pump will remain ON for the time set in "Backup Float Run Time" after the float drops. If the controller is not working both pumps will be operated by this float switch. The alarm beacon and horn will turn ON when this float is activated.

## **LOW LEVEL CUT-OUT FLOAT (IN AUTO MODE)**

A low level cut out float switch may be used to stop the pump operation if the level is too low.

NOTE: This float switch does not have an indication nor does it sound the alarm. Ensure it is mounted well below the LEAD PUMP OFF and LAG PUMP OFF levels set in the controller. If this float switch fails, the pump will not operate.

## **ALARM LEVELS**

The alarm beacon and the horn will activate on the following level conditions:

- If the level rises above the back up HIGH LEVEL float switch
- If the level rises above the HIGH LEVEL set point (transmitter)

***VERIFY CORRECT OPERATION OF CONTROL PANEL  
AFTER INSTALLATION IS COMPLETE.***

## LEVEL SENSORS INSTALLATION

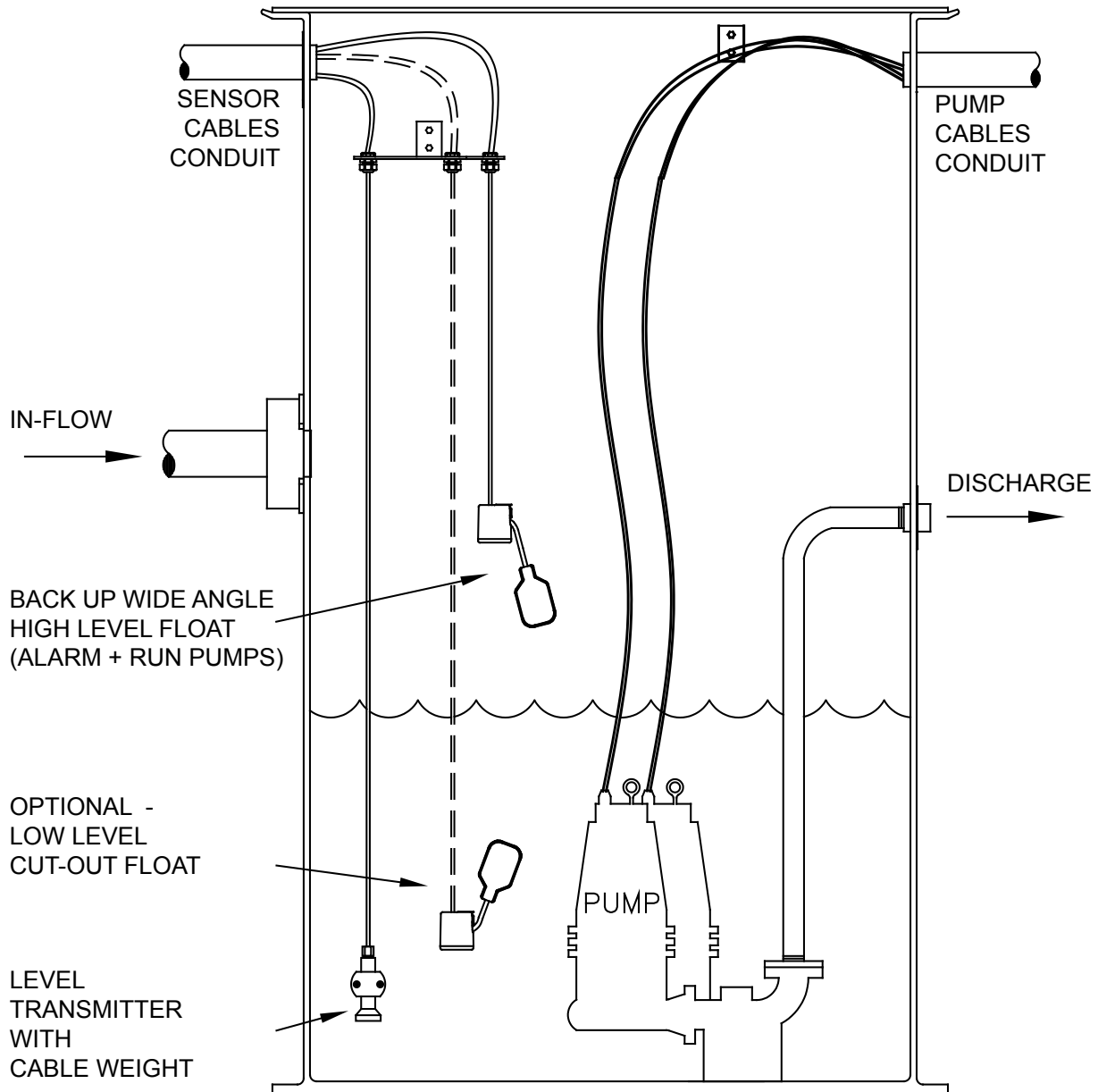

Typical transmitter (with high level float back up) setup for a duplex lift station

**WARNING:**  
Keep sensors clear of pumps, pipes, and motor cables.  
Ensure that floats cannot reach pump suction.  
Do not run pump and float cables in the same conduit.

# SETTING UP THE TPC-X CONTROLLER

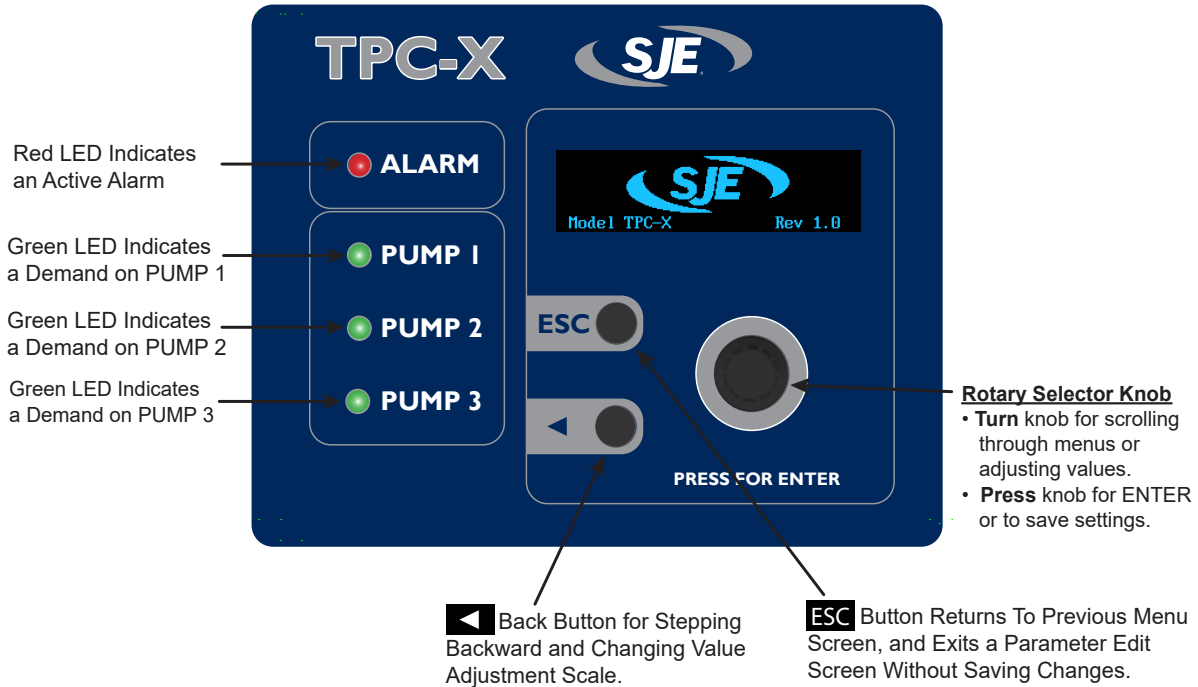

## MAIN SCREEN

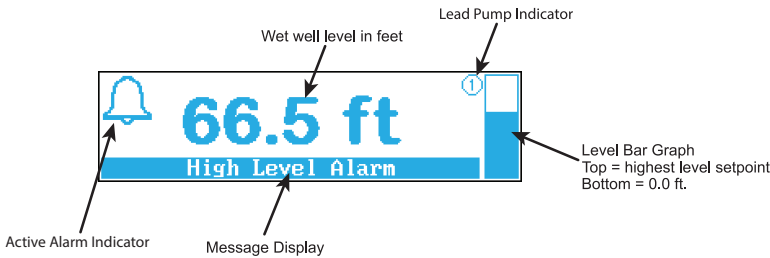

The main screen displays the set well level and any active alarms. The controller will return to the main screen automatically after 3 minutes of inactivity.

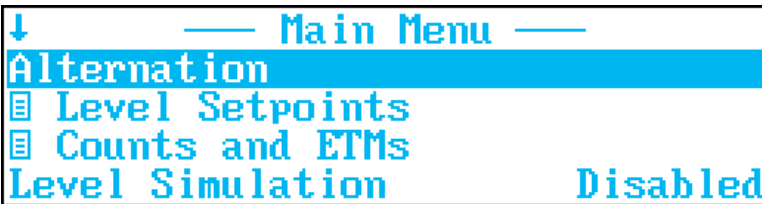

From the main screen, press the selector wheel to reach the main menu. All menu items can be seen by turning the selector wheel to access the highlighted menu item.

**Alternation:** Select the pump operation sequence

**Level Setpoints:** Select Lead, Lag, and Alarm wet well level setpoints. Rotate the selector wheel to highlight the level to be adjusted and press the wheel to access the adjustment. Rotate the selector wheel to change to the desired set point and press the wheel to store the new level.

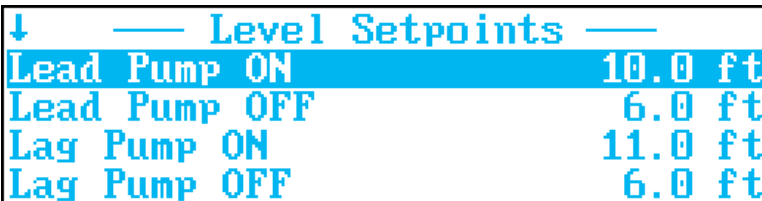

**NOTE:** Consult the TPC-X manual for detail information on the controller setup and operation.

Download at [www.csicontrols.com](http://www.csicontrols.com)

## ALARMS

ALARM TEXT	DEFINITION	FIX
<b>HIGH LEVEL ALARM</b>	The level is at or above the High Level setpoint	Check pump operation, check in-flow, check level transmitter
<b>HIGH LEVEL FLOAT</b>	The high level (backup) float is closed	Check pump operation, check in-flow, check level transmitter
<b>HIGH LEVEL FLOAT (LATCHED)</b>	The high level (backup) float had closed in the past, but is now open	Press ESC to reset, check pump operation, check in-flow, check level transmitter
<b>LOW LEVEL ALARM</b>	The level is at or below the Low Level setpoint	Check wet well, check level transmitter
<b>PUMP 1 DISABLED</b>	The Pump 1 Disable input is closed	Open the Pump 1 Disable input
<b>PUMP 1 FAILED TO START</b>	Pump 1 was called to run but the Pump 1 Aux input did not close within the user-specified time	Press ESC to reset, check pump operation, check overload trip
<b>PUMP 1 SEAL FAIL</b>	The Pump 1 seal probe input resistance to ground has dropped below 50k $\Omega$ (or above 75k $\Omega$ if Seal Fail Polarity is set to INVERTED)	Check pump seal
<b>PUMP 1 TEMP FAIL</b>	The Pump 1 temp input is open	Check voltage, pump clogging, or wear
<b>PUMP 1 TEMP FAIL (LATCHED)</b>	The Pump 1 temp input had opened in the past, but is now closed again	Press ESC to reset, check voltage, pump clogging, or wear
<b>PUMP 2 DISABLED</b>	The Pump 2 Disable input is closed	Open the Pump 2 Disable input
<b>PUMP 2 FAILED TO START</b>	Pump 2 was called to run but the Pump 2 Aux input did not close within the user-specified time	Press ESC to reset, check pump operation, check overload trip
<b>PUMP 2 SEAL FAIL</b>	The Pump 2 seal probe input resistance to ground has dropped below 50k $\Omega$ (or above 75k $\Omega$ if Seal Fail Polarity is set to INVERTED)	Check pump seal
<b>PUMP 2 TEMP FAIL</b>	The Pump 2 temp input is open	Check voltage, pump clogging, or wear
<b>PUMP 2 TEMP FAIL (LATCHED)</b>	The Pump 2 temp input had opened in the past, but is now closed again	Press ESC to reset, check voltage, pump clogging, or wear
<b>TRANSDUCER SHORT CIRCUIT</b>	The 4-20mA level input signal is greater than 20.25 mA	Check level transmitter operation, wiring, and vent tube.
<b>TRANSDUCER OPEN CIRCUIT</b>	The 4-20mA level input signal is less than 3.75 mA	Check level transmitter operation, wiring, and vent tube.

## TPC-X CONTROLLER SETPOINTS LIST

<b>STATION NAME:</b>					
<b>START UP DATE:</b>					
<b>CONTROLLER REV:</b>					
	<b>MIN</b>	<b>MAX</b>	<b>DEFAULT VALUE</b>	<b>USER SETTING</b>	
<b>LEVEL SETPOINTS</b>					
	Lead Pump ON	0	999.9	<b>7.0</b>	
	Lead Pump OFF	0	999.9	<b>4.0</b>	
	Lag Pump ON	0	999.9	<b>8.0</b>	
	Lag Pump OFF	0	999.9	<b>4.0</b>	
	Lag2 Pump ON	0	999.9	<b>9.0</b>	
	Lag2 Pump OFF	0	999.9	<b>4.0</b>	
	High Level Alarm	0	999.9	<b>10.0</b>	
	Low Level Alarm	0	999.9	<b>3.0</b>	
<b>ADVANCED SETTINGS</b>					
	Transducer Range	1.0	999.9	<b>15.0</b>	
	Level Offset	0	999.9	<b>1.0</b>	
	Number Of Pumps	1	3	<b>2</b>	
	Pump ON Delay	0	250	<b>5 sec</b>	
	Pump OFF Delay	0	250	<b>5 sec</b>	
	Setpoint Dwell Time	0	99	<b>2 sec</b>	
	Backup Float Run Time	0	999	<b>0 sec</b>	
	Aux/Dis Input Function	List		<b>Feedback</b>	
	Starter Run Feedback Time	1	99	<b>2 sec</b>	
	Seal Fail Polarity	List		<b>Normal</b>	
	Temp Fail Reset Mode	List		<b>Auto-Reset</b>	
	Aux Relay Function	List		<b>Horn</b>	
	Max Pumps On At Once	1	3	<b>2</b>	
	Analog Out Low Level	0	999.9	<b>0.0</b>	
	Analog Out High Level	0	999.9	<b>16.0</b>	
	Level Units	List		<b>Feet</b>	
	Pumping Direction	List		<b>Down</b>	
<b>STATION DATA</b>					
	Pump Horsepower	0	999	<b>10</b>	
	Pump Voltage	0	999	<b>460</b>	
	Pump FLA	0	999.9	<b>15.0</b>	
	Tank Diameter	0	999.9	<b>6.0</b>	
<p><b>Warning: Users must read this manual and understand controller operation before changing any settings. Entering incorrect settings may result in damage to equipment.</b></p> <p><b>If the TPC-X controller was shipped pre-installed in a control panel, some default values may have been changed at the factory in order to properly test the control panel operation. The user must adjust the settings to the requirements of their particular installation</b></p> <p><b>The user should always keep a record of the settings before making changes, in case there is a need to revert to previous settings. The user should also record all settings changed for use in programming a new controller in case a replacement is ever needed.</b></p> <p><b>Always thoroughly test controller operation in the installed configuration to verify user settings.</b></p>					







# CSI Controls™

Technical support: +1-800-746-6287

[techsupport@sjeinc.com](mailto:techsupport@sjeinc.com)

[www.csicontrols.com](http://www.csicontrols.com)

Technical Support Hours: Monday-Friday, 7 A.M. to 6 P.M. Central Time

PN 1051956B 01/20

© 2020 SJE, Inc. All Rights Reserved.  
CSI CONTROLS is a trademark of SJE, Inc.