



Duplex Model Shown

## RK Series™ Control Panel 4-20mA Transmitter Models

### Installation and Operation Manual



#### Parts included



\*Quantity = 1



\*Quantity = 1 or 2

\*Control panel may be ordered with or without these items.



### WARNING!



#### ELECTRICAL SHOCK HAZARD

Disconnect all power sources before servicing. Failure to do so could result in serious injury or death.

This control panel must be installed and serviced by a licensed electrician in accordance with the National Electric Code NFPA-70, state and local electrical codes. UL Type 4X enclosures are for indoor or outdoor use.

**Warranty void if panel is modified.**

CSI Controls® offers a five-year limited warranty on most standard catalog products. For complete terms and conditions, please visit [www.csicontrols.com](http://www.csicontrols.com).

Products returned must be cleaned, sanitized, or decontaminated as necessary prior to shipment to ensure that employees will not be exposed to health hazards in handling said material. All applicable laws and regulations shall apply.

For technical support:  
email: [techsupport@sjeinc.com](mailto:techsupport@sjeinc.com)  
phone: +1-800-746-6287  
[www.csicontrols.com](http://www.csicontrols.com)

## Installing the Transmitter and Float Switches

The RK Series™ Single Phase control panel operates with one 4-20mA submersible level transmitter and one or two backup float switches.

### 1 ⚠️ WARNING!

Ensure all power is turned OFF before installing floats in tank. Failure to do so could result in serious or fatal shock.

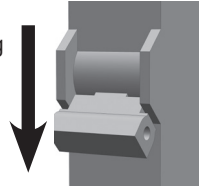

### 2 ⚠️ CAUTION!

If the floats are not properly mounted and connected in the correct order, the pumps will not function properly.

Floats require free range of motion.

**⚠️ WARNING:** To prevent erroneous measurements, do not allow the sensor diaphragm to come into contact with solid objects or sludge. Do not use level measurements less than 4" (10.2 cm) for control or alarm purposes (dead band).

**Caution:** Do not overtighten clamp or tie straps.

### 2-Float & Transmitter Installation

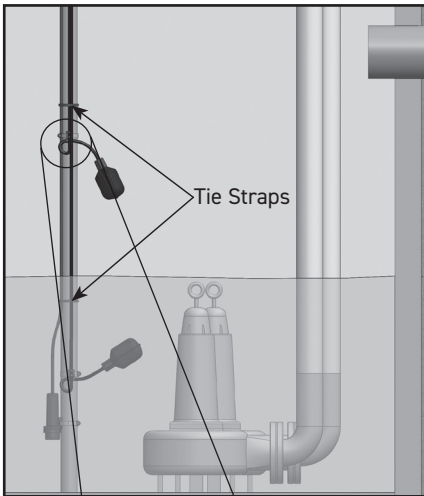

**⚠️ WARNING:** DO NOT support transmitter by the cable.

**⚠️ WARNING:** DO NOT kink or place cable under hose clamp. Doing so may cause failure.

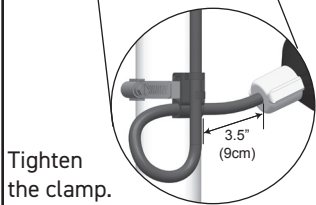
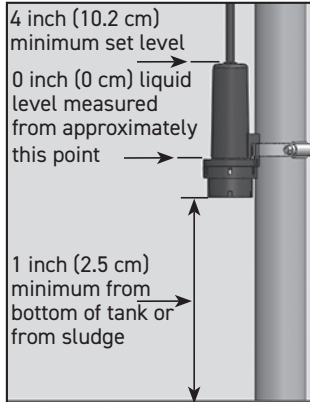

Tighten the clamp.

Hose clamp is 18-8 stainless steel. Contact your CSI Controls supplier for replacements.

Make sure hose clamp band does not interfere with float operation.

Do not install cord under hose clamp.

Replace product immediately if switch, cable weight or cable is damaged or cracked.

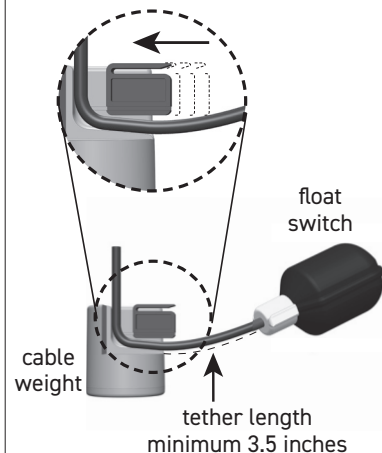

## Mounting the Control Panel

Mount control panel using integrated mounting flange.

### NOTE

If the distance to the control panel exceeds the length of the float switch cords or the pump power cord, splicing in a liquid-tight junction box will be required. For outdoor or wet installation, we recommend a UL Type 4X junction box.

## Wiring the Control Panel

1 Determine conduit entrance locations on control panel as shown. Check local codes and wiring diagram on the inside cover of the panel for the number of power circuits required.

### ⚠️ CAUTION!

Be sure the pump power voltage and phase are the same as the pump motor being installed.

Use of separate pump and control/alarm power sources is recommended.

2 Connect the following wires to the proper terminal positions:

- incoming power for each pump circuit
- incoming power for control/alarm circuit
- pump 1
- pump 2 (Duplex)
- backup float switches
- 4-20mA transmitter

### ⚠️ CAUTION!

You must use conduit sealant to prevent moisture or gases from entering the panel.

Type 4X conduit must be used to maintain a Type 4X rating of the control panel.

3 Verify correct operation of control panel after installation is complete.

## Operations

This RK Series™ control panel uses a 4-20mA level transmitter.

**Hand Operation** - If the level is above the "Pump Off Setpnt" and the Low level back up Float Switch is UP, press the "HAND" switch momentarily and the pump will run until the level drops below the "Pump Off Setpnt" or the float opens, or press the "HAND" switch again to stop the pump. For Time dose operation, the HAND pump operation is limited by the "Pump On Time".

Press and hold the "HAND" switch to operate the pump if the Low Level Backup float is OPEN or the level is below the "Pump Off Setpnt".

Off Operation - Turn corresponding breaker off to be in Off operation.

**Auto Operation** - In timed dose mode, the timer controls the pump ON and OFF time as long as the well level is above the "Lead ON Setpoint" and the Low Level backup float is CLOSED. If the level drops below the "Off Setpoint", the timer will stop the pump and end the dose prematurely.

In demand mode, the level transmitter controls the pumps. The lead pump will start when the level rises above the "Lead ON Setpoint" and run until the level drops below "Off Setpoint".

### Power and Blown Fuse Indicators

The Control and Alarm circuits each have a green LED indicator when power is applied.

If a fuse is blown, the red fuse blown LED indicator above the fuse will turn ON.

# Controller Navigation and Setup

**Depth**  
**100.5 inches**



Menu/Enter Button



Set/Change Button

## Viewing or Changing Parameters:

Press the Menu/Enter button to advance to the next menu.

Press and hold the Menu/Enter button for 3 seconds to access setting Menus.

Press Set/Change button to access Setting Menus and to edit/view parameters/function.

After 60 seconds of no activity in the Settings Menu the controller will go back to Main Display Menus.

## Screen Navigation (Duplex Demand) - Complete Navigation found on the back of this Manual.

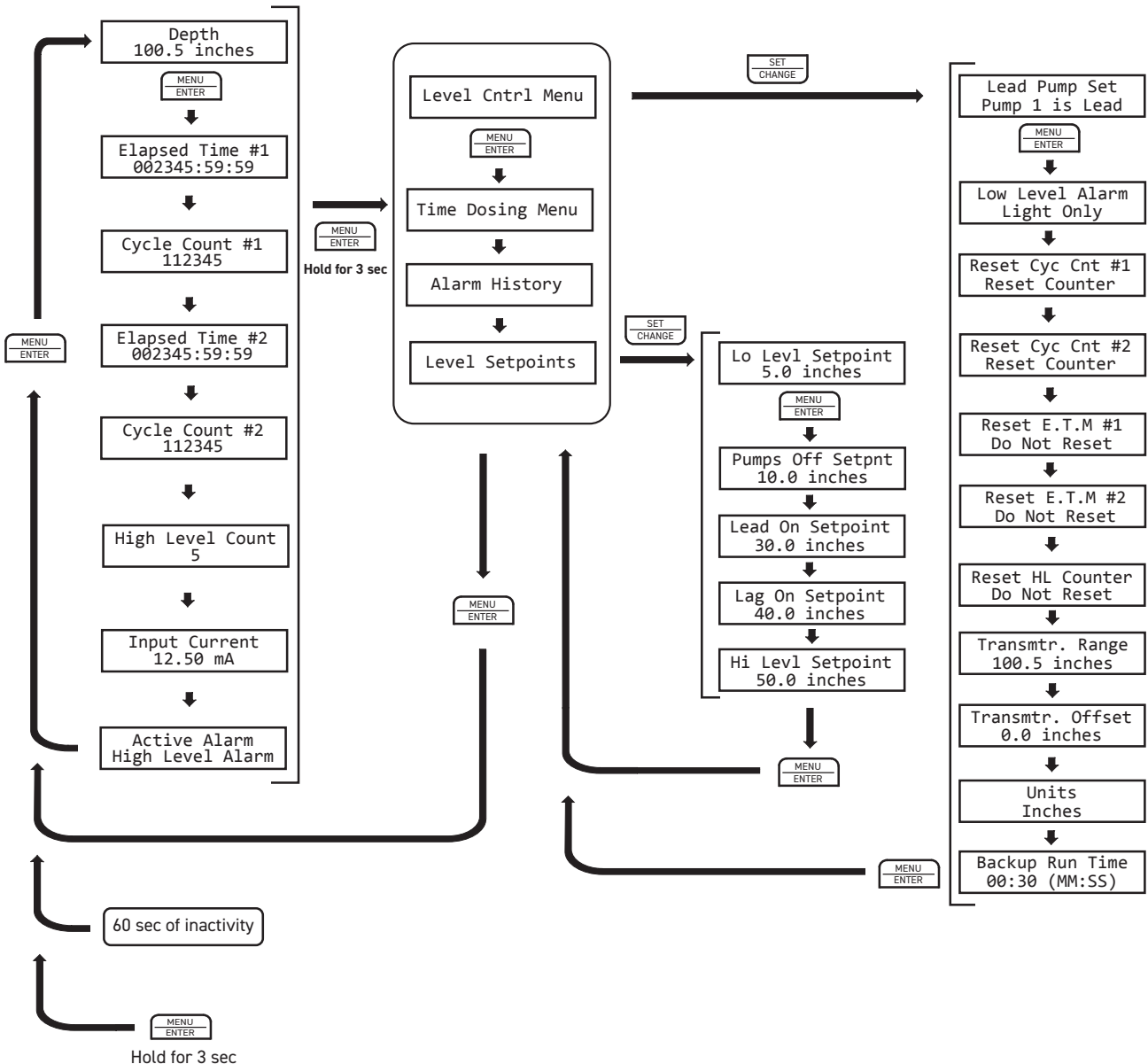

## Editing Parameters

Example: Changing the **Pumps Off Setpoint** from 10.0 inches to 12.5 inches.

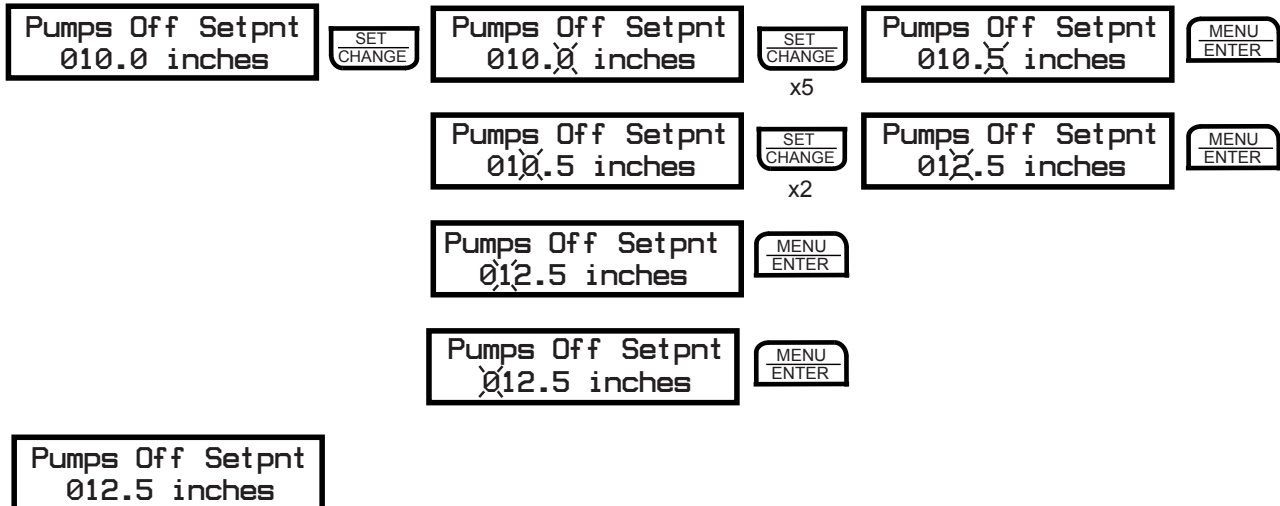

## Parameters

Level Cntrl Menu	Default Value	Min	Max	User
Lead Pump Set	Alternate	Alternate, Pump 1 is Lead, Pump 2 is Lead		
Low Level Alarm	Light Only	Alarm Off, Light Only, Light & Audible		
Reset Cyc Cnt #1	Do Not Reset	Do Not Reset, Reset Counter		
Reset Cyc Cnt #2	Do Not Reset	Do Not Reset, Reset Counter		
Reset E.T.M. #1	Do Not Reset	Do Not Reset, Reset Counter		
Reset E.T.M. #2	Do Not Reset	Do Not Reset, Reset Counter		
Reset HL Counter	Do Not Reset	Do Not Reset, Reset Counter		
Reset Ovr. Cnt.	Do Not Reset	Do Not Reset, Reset Counter		
Transmtr. Range	100.5 inches	1.0 inches	999.9 inches	
Transmtr. Offset	000.0 inches	0.0 inches	999.9 inches	
Units	Inches	Inches, Feet, Meters, Centimeters		
Backup Run Time	00:30 (MM:SS)	00:00	99:59	
Time Dosing Menu	Default Value	Min	Max	User
Pump 1 Time On	01:00 (MM:SS)	00:01	99:59	
Pump 1 Time Off	00:00 (HH:MM)	00:01 (00:00=demand operation)	99:59	
Pump 1 Ovrriid On	02:00 (MM:SS)	00:01	99:59	
Pmp 1 Ovrriid Off	06:00 (HH:MM)	00:01	99:59	
Pump 2 Time On	01:00 (MM:SS)	00:01	99:59	
Pump 2 Time Off	06:00 (HH:MM)	00:01	99:59	
Pump 2 Ovrriid On	02:00 (MM: SS)	00:01	99:59	
Pmp 2 Ovrriid Off	06:00 (HH:MM)	00:01	99:59	
Alarm/Override	Override-No Warn	Override-No Warn, No Override, Override On		
High Level Delay	00:10 (MM:SS)	00:00	99:59	
Number of Fields	One Field	One Field	Two Fields	
Level Setpoints	Default Value	Min	Max	User
Lo Levl Set point	005.0 inches	000.0	999.9	
Pumps Off Setpnt	010.0 inches	000.0	999.9	
Lead On Setpoint	030.0 inches	Pumps Off Setpoint	999.9	
Lag On Setpoint	040.0 inches	Lead On Setpoint	999.9	
Hi Levl Setpoint	050.0 inches	000.0	999.9	

# Field Wiring Connections

Terminal Strip example for duplex single phase pumps with no overload.

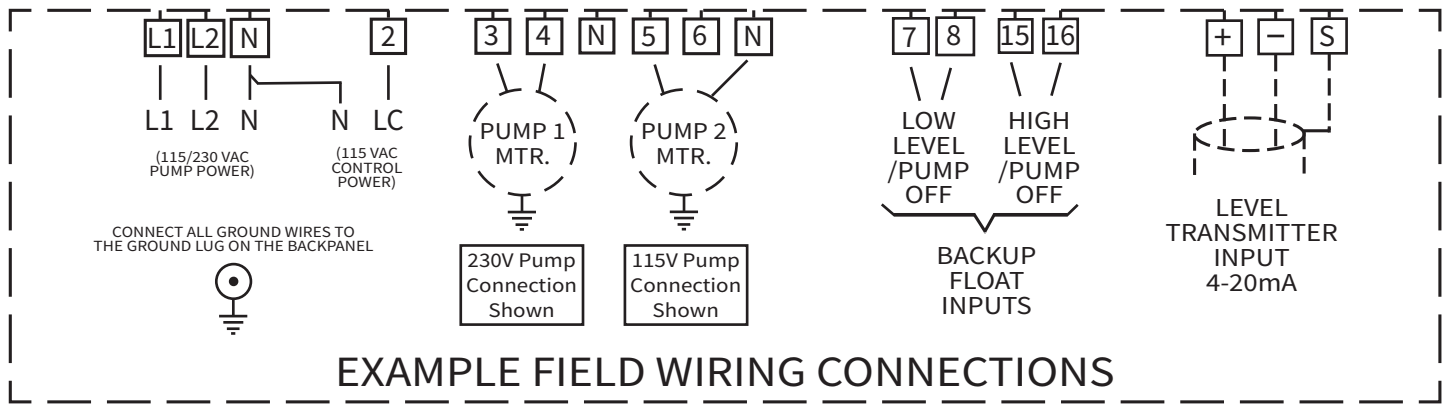

Note: This is only a sample, please follow the specific connection instructions located inside your panel.

## Connecting the Level Transmitter:

Terminal Label	Description	Wire Color for CSI Controls Transmitters
<b>+</b>	+24VDC	Black
<b>-</b>	Analog 4-20mA Input	White
<b>S</b>	Shield	Bare

Terminate transmitter cable in the control panel and connect wires to proper terminals as shown on the control panel schematic. The vent tube opening must be kept in a clean and dry environment. Run the level transmitter cable all the way to the control panel. Ensure proper sealing of conduits as to prevent gases and moisture from entering the control panel. Do not terminate in the wet well, even in a junction box.

**Caution:** If the level transmitter wires are not connected properly, the 4-20mA signal output will not be correct. Level transmitter and float cables need to run in separate conduit from pump and power cables.

**Do not splice in the wet well.**

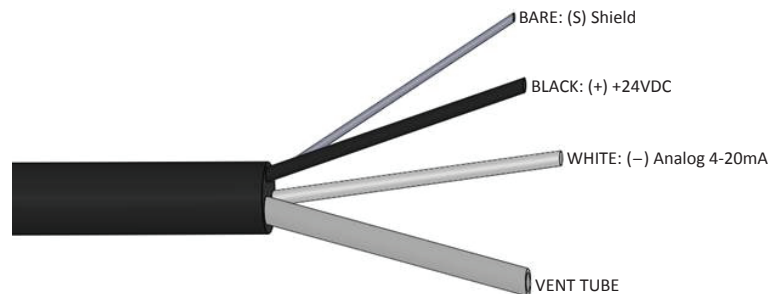

## Troubleshooting

Alarm Light Flash Pattern	Audible Alarm Pattern	Alarm Description	Active Alarm Screen Text	Other Indications
2 per second	2 per second	High Level	High Level Alarm	Aux Contact Closed Alarm LED flashing
1 every 4 sec.	1 every 4 sec.	Control Fuse Fail	Cntrl Power Fail	Control Power LED Off Control Fuse LED On
None	1 every 4 sec.	Alarm Fuse Fail	Alarm Power Fail	Alarm Power LED Off Alarm Fuse LED On
1 every 4 sec.	1 every 4 sec.	Control Power Fail	Cntrl Power Fail	Control Power LED Off Control Fuse LED Off
None	1 every 4 sec.	Alarm Power Fail	Alarm Power Fail	Alarm Power LED Off Alarm Fuse LED Off
1 every 4 sec.	1 every 4 sec.	Timer Override Warning	Override Warning	
1 every 16 sec.	1 every 16 sec.	Backup Mode Warning	In Backup Mode	In Backup Mode LED On
1 long flash every 2 sec.	1 per second (if enabled)	Low Level	Low Level Alarm	Alarm LED flashing

# Complete Screen Navigation

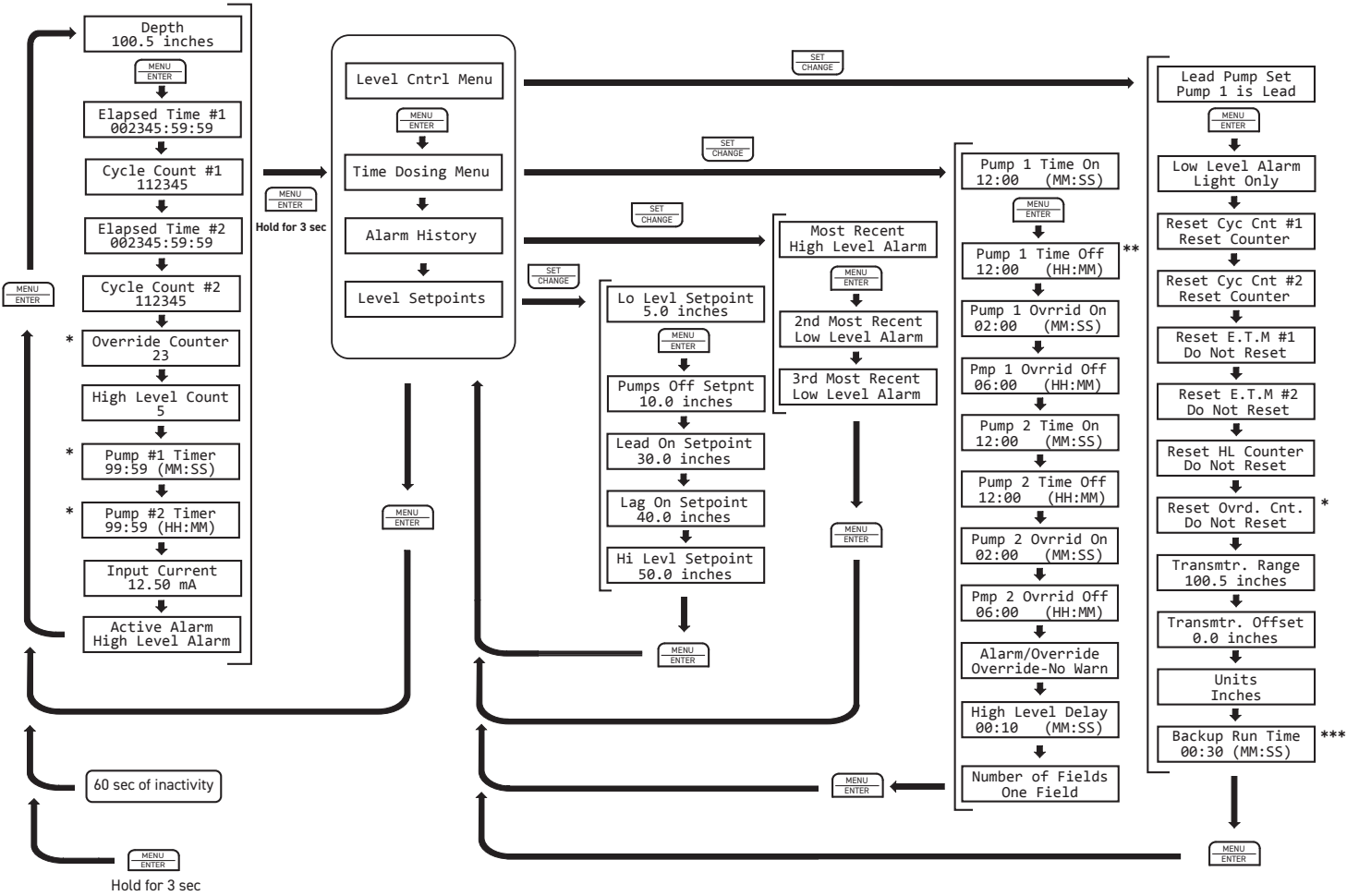

\* Only appears in Time Dose Mode  
 \*\* Set to 00:00 for Demand Mode Operation  
 \*\*\* Only appears in Demand Mode



+1-800-746-6287  
 techsupport@sjeinc.com  
 www.csicontrols.com  
 Technical Support Hours: Monday - Friday, 7 A.M. to 6 P.M. Central Time