

SpecPAK

INLINE 1100 COMPACT, MULTI-PUMP SYSTEM

The Franklin Electric Inline 1100 SpecPAK™ Pressure Boosting System connects easily to nearly any commercial, industrial, or multi-residential plumbing configuration to provide an easy to size water pressure boosting solution. Contractors simply determine how much water is required to be boosted to the desired constant pressure output and the system comes properly packaged. The pump itself, the Franklin Electric Inline 1100, is a quiet, all-in-one constant water pressure system that contains the pump, motor, and drive in a compact package. As water volume needs increase, the pump instantly accelerates to the proper speed to ensure the water pressure stays constant throughout the application.



Meets the Requirements of NSF 372





INLINE 1100 SPECPAK

FEATURES

- All stainless components for corrosion resistance and uncompromised water quality
- Electrical design with multiple fuses to prevent surge damage to control electronics
- Manifold and pump circuit piping sized to accommodate a full range of flows with minimal losses from hydraulic friction
- Grooved plumbing connections reduce set-up time and minimize external stress transfers between piping connections
- Full port ball valves used to reduce pressure loss through fittings and maintain smooth, consistent water velocities through the system

EASE OF INSTALLATION

- Flexibility to add pump modules to the base package so the system can grow to accommodate new or unexpected water demands (PATENT PENDING)
- Quick connections within the individual pump circuit piping allowing service/installations to be performed with minimal labor and tools
- Wall-hung unit minimizes the required installation space, preserving critical floor space while allowing for easier, eye-level system maintenance
- Compact footprint
- 44-3/16" vertical distance between inlet/outlet manifolds
- 64.25-68.25" total height including the control panel
- 14.5" total depth
- 30.125-52.125" wide
- UL508A panel with lockable electrical disconnects
- Prewired electrical quick connectors between each pump and the control panel
- Complete package system provides pressure and flow in a simple, single unit

CONTROL PANEL

- Color-touchscreen, Programmable Logic Control (PLC) allows for system control without opening the panel
- Modbus, ethernet, or cell radio communication capable (requires optional card) allowing for remote monitoring and control
- Lead/lag or parallel pump operation can be easily selected through system settings
- Allows for various lead pump rotation balancing schemes, providing choices for a multitude of setup configurations
- Allowance for operation in a commissioning mode within the control sequence
- Lockable fused branch disconnects allow offline pump to receive maintenance while remaining pumps stay online
- Field programmable to allow for firmware updates



Meets the Requirements of NSF 372

INLINE 1100 SPECPAK

MODEL NOMENCLATURE

2 | L - 2 3 0 3 3 - G 1 T - C

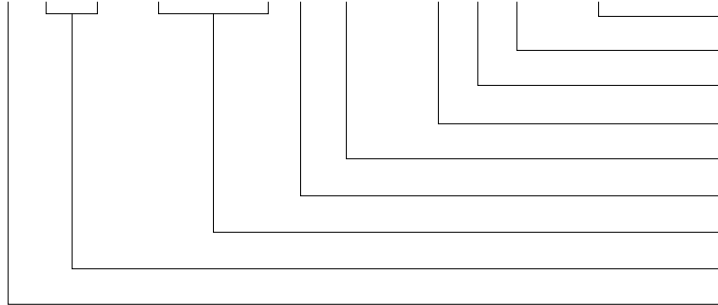

- (C) Suction-Side Check Valve (Blank: No Check Valve)
- (T) Transducer, (S) Switch
- (I) with Tank, (O) without Tank
- (G) Grooved (T) Threaded Connection Style
- Outlet Plumbing side in Inches (14, 1-1/4"; 3, 3.0")
- Inlet Plumbing Size in Inches (14, 1-1/4"; 3, 3.0")
- Input Voltage
- Product Family Type (Inline 1100)
- Number of Pumps in Package (1, 2, 3, 4)

DIMENSIONS & SPECIFICATIONS

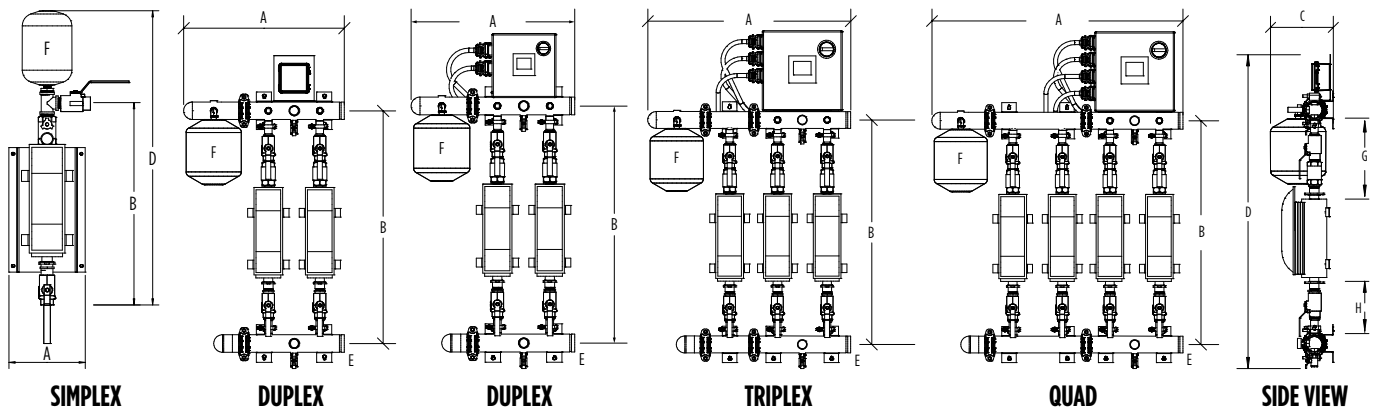

Standard Version															
Description	Order No.	Model No.	Width	Manifold Distance	Depth	Overall Height	Site Connection	Tank Capacity	Discharge Circuit	Suction Circuit	No. of Pumps	Max. Flow (GPM)	Max. Boost (PSI)	Volts	Max. Amps
			A	B	C	D	E	F	G	H					
Simplex	574705900	1IL-2301414-TIS	12-1/8"	32-1/2"	14-1/2"	47-1/4"	1-1/2" FNPT	2.0 Gal	1-1/2"	1-1/2"	1	40	60	230 V	12.0
Duplex w/ alternator	574705901	2IL-23033-GIS	32-1/8"	44-3/16"	14-1/2"	64-1/2"	3" Groove	4.8 Gal	13.41"	8.25"	2	80	60	230 V	26.5
Duplex w/ CP and pressure transducer	574705902	2IL-23033-GIT	32-1/8"	44-3/16"	14-1/2"	64-1/2"	3" Groove	4.8 Gal	13.41"	8.25"	2	80	60	230 V	26.5
Triplex w/ CP and pressure transducer	574705903	3IL-23033-GIT	42-1/8"	44-3/16"	14-1/2"	68-1/2"	3" Groove	4.8 Gal	13.41"	8.25"	3	120	60	230 V	38.5
Quad w/ CP and pressure transducer	574705904	4IL-23033-GIT	51-1/8"	44-3/16"	14-1/2"	68-1/2"	3" Groove	4.8 Gal	13.41"	8.25"	4	160	60	230 V	50.5

With Suction-Side Check Valve Included															
Description	Order No.	Model No.	Width	Manifold Distance	Depth	Overall Height	Site Connection	Tank Capacity	Discharge Circuit	Suction Circuit	No. of Pumps	Max. Flow (GPM)	Max. Boost (PSI)	Volts	Max. Amps
			A	B	C	D	E	F	G	H					
Simplex	574705900C	1IL-2301414-TIS-C	12-1/8"	37-13/16"	14-1/2"	52-9/16"	1-1/2" FNPT	2.0 Gal	1-1/2"	1-1/2"	1	40	60	230 V	12.0
Duplex w/ alternator	574705901C	2IL-23033-GIS-C	32-1/8"	49-1/2"	14-1/2"	67-1/8"	3" Groove	4.8 Gal	13.41"	8.25"	2	80	60	230 V	26.5
Duplex w/ CP and pressure transducer	574705902C	2IL-23033-GIT-C	32-1/8"	49-1/2"	14-1/2"	69-7/8"	3" Groove	4.8 Gal	13.41"	8.25"	2	80	60	230 V	26.5
Triplex w/ CP and pressure transducer	574705903C	3IL-23033-GIT-C	42-1/8"	49-1/2"	14-1/2"	73-7/8"	3" Groove	4.8 Gal	13.41"	8.25"	3	120	60	230 V	38.5
Quad w/ CP and pressure transducer	574705904C	4IL-23033-GIT-C	51-1/8"	49-1/2"	14-1/2"	73-7/8"	3" Groove	4.8 Gal	13.41"	8.25"	4	160	60	230 V	50.5



INLINE 1100 SPECPAK

FAMILY CURVE

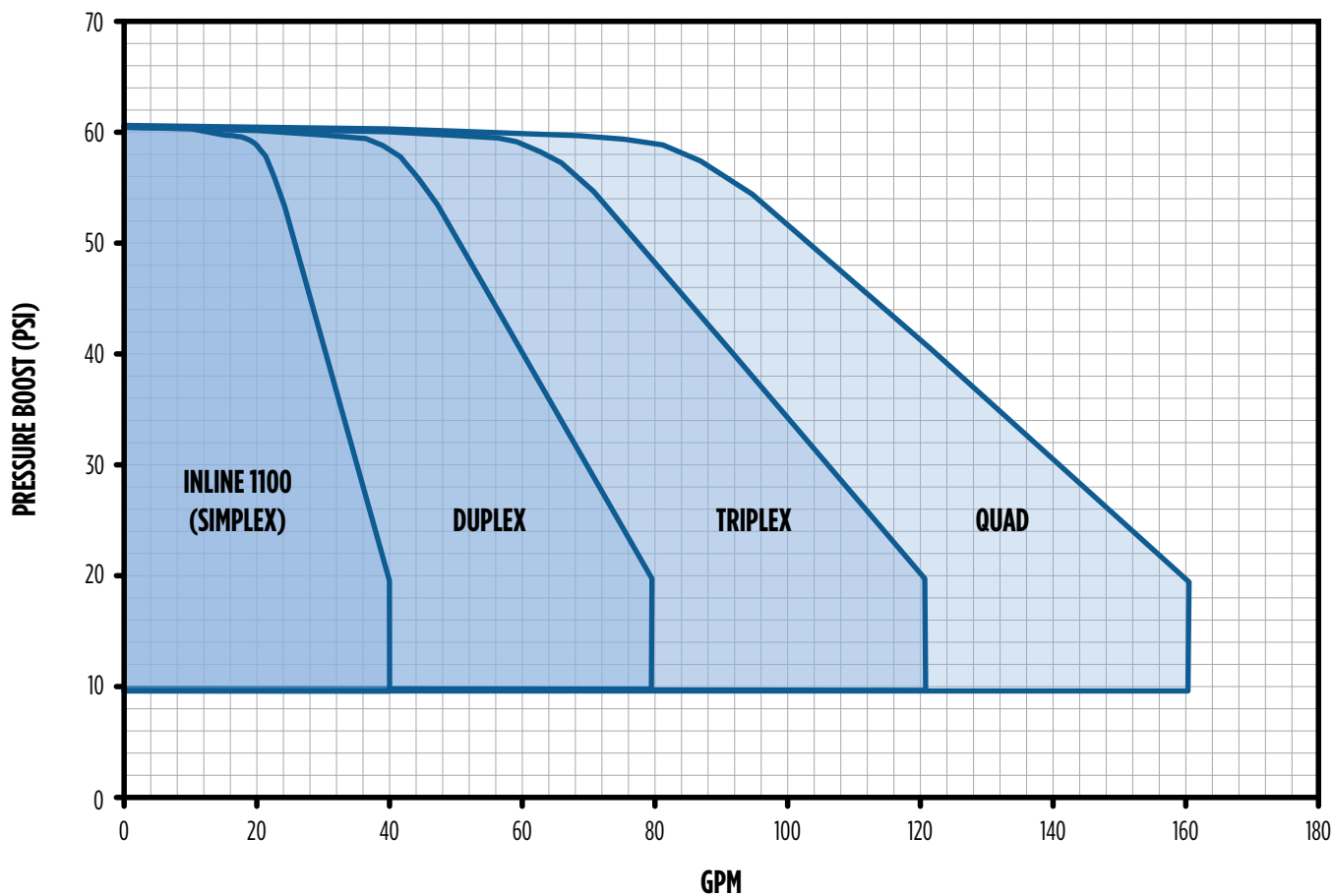

INLINE 1100 SPECPAK

TYPICAL SITE PLUMBING CONFIGURATION

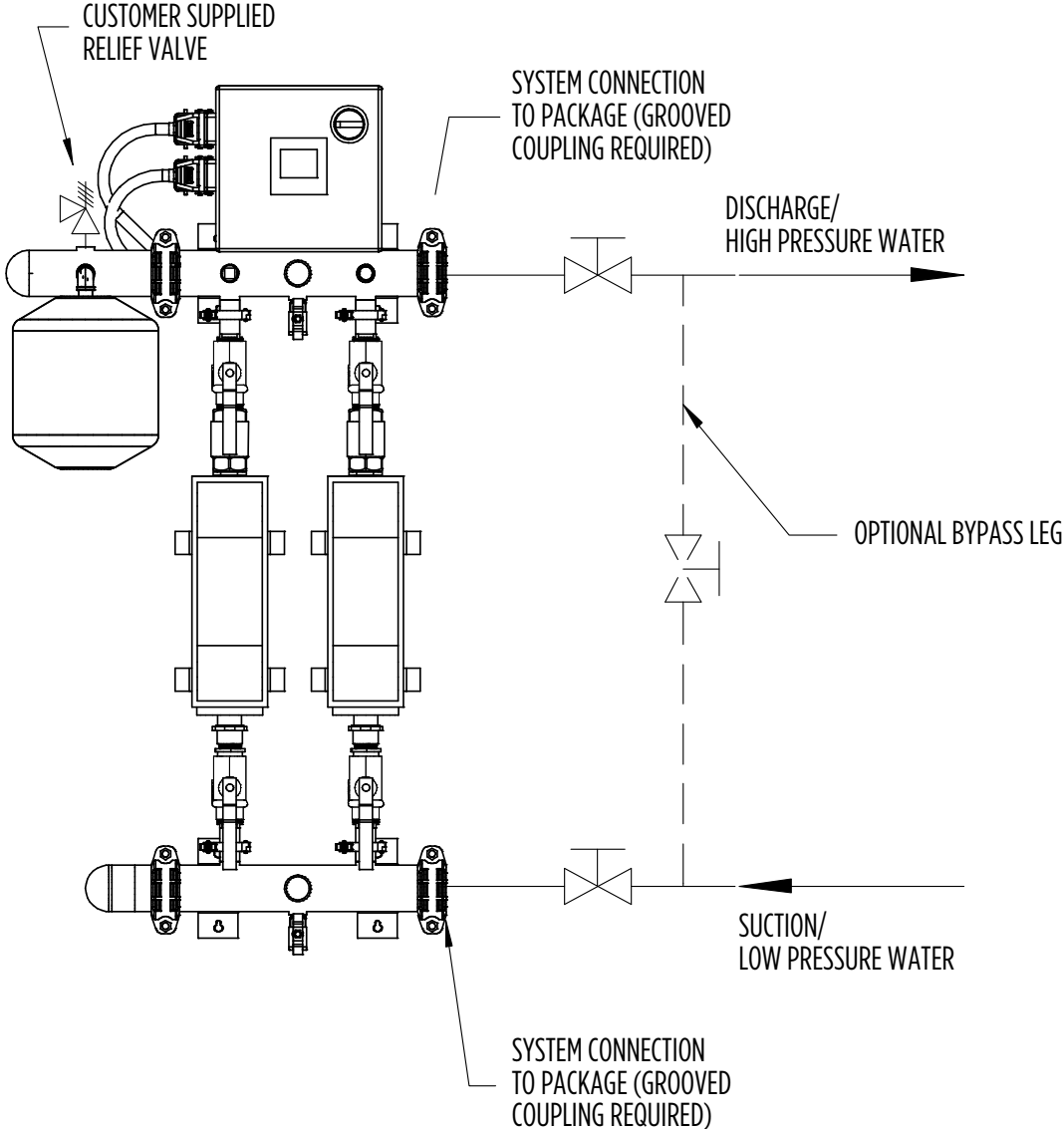



INLINE 1100

DIMENSIONS & SPECIFICATIONS

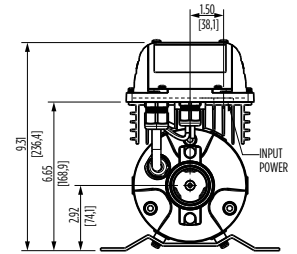
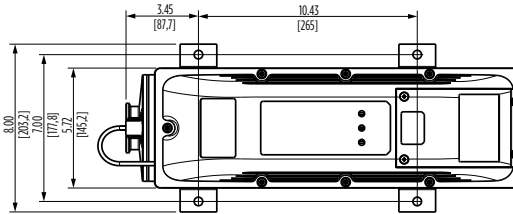
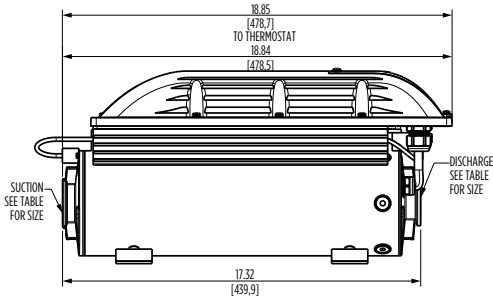

Ratings, Capacities, and Electric Details	
Flow Range	0-40 GPM
Required Inlet Pressure	2-5 PSI
Discharge Pressure	Up to 60 PSI boost. Standard max. outlet 80 PSI, optional high press outlet 100 PSI.
Electrical Requirements	240 V, 1-PH, 60 Hz
Max. Operating Amps	12A
Max. Water Temperature	104 °F (40 °C)
Control Panel Items	NEMA 4 rated electrical termination housing. Pump includes motor, variable speed drive, pressure switch, and overtemp switch.

Model Description	Order No.
25SDIL1100N4* (Complete pump w/NPT)	90401101
25SDIL1100N4-B* (Complete pump w/BSP)	90401102
Electronic Drive Assembly	305707901
Pump & Motor Assembly w/NPT	305707902
Pump & Motor Assembly w/BSP	305707911
Mounting Feet	305707903
Pressure Switch	305707906
Pressure Tank (2 gallon)	305707910
Fastener Kit	305707904
Pressure Switch Cable	305707905
Overpressure Switch**	305707909
Overpressure Switch Cable**	305707908
Overpressure Switch & Cable Combo**	305707912
Thermostat Kit	305707917

* Includes pump, motor, drive, pressure switch, and all cables.

** Overpressure switch is sold as an accessory and is not required for normal operation.

SYSTEM COMPONENTS

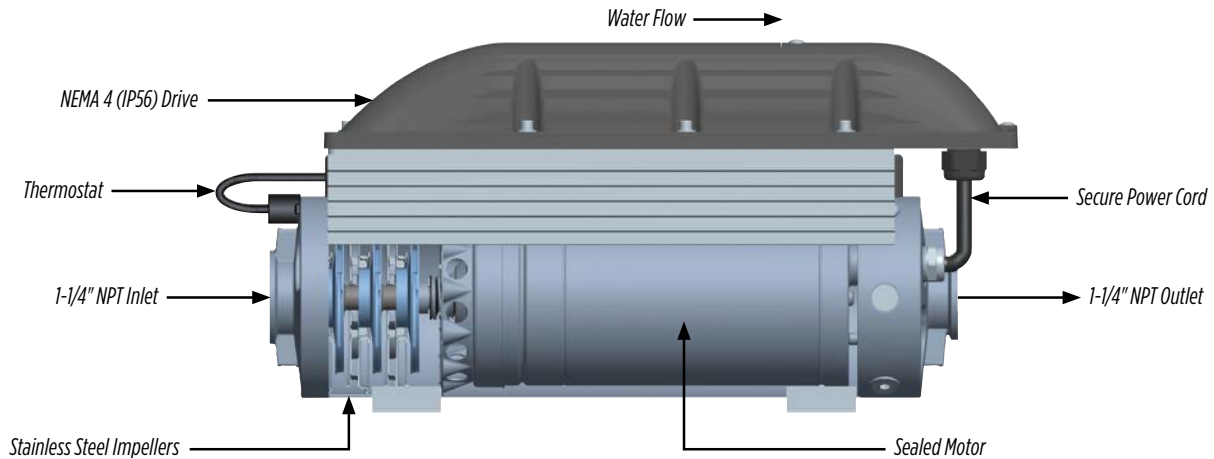

INLINE 1100 SIMPLEX SPECPAK

DIMENSIONS & SPECIFICATIONS

FRONT VIEW

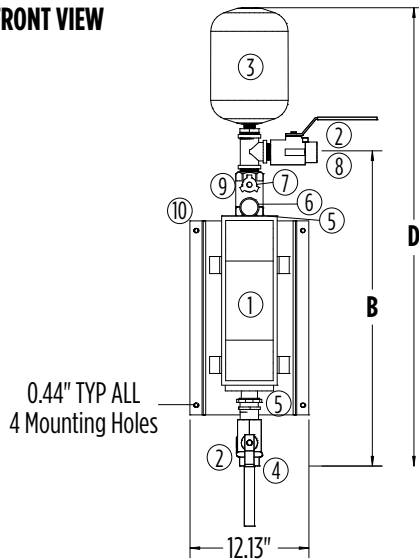

Version (see pg. 3)	Manifold Distance - B	Overall Height - D
Standard	32-1/2"	47-1/4"
With Suction-Side Check Valve Included	37-13/16"	52-9/16"

Connections and Major Component List		
No.	Part Name	Description
1	Franklin Electric Inline 1100 Variable Speed Pump	304 SS/316 SS
2	Isolation Valve	304 SS, 2 Piece, 200 WOG, THD ball valve
3	Pressure Tank	2 gal tank with rubber bladder 150 PSI rated
4	Suction Side Connection	1-1/2" NPT female threaded connection to isolation valve
5	Pump Connections	1-1/4" 304 SS oval flange
6	Pressure Switch	0-80 PSI 1/4" NPT
7	Pressure Gauge	Liquid filled pressure gauge 0-100 PSI scale
8	Discharge Connection	1-1/2" NPT female threaded connection to isolation valve
9	Check Valve	1-1/2" SS inline spring check valve
10	Frame	304 SS 10 gauge mounting frame with six mounting holes

Ratings, Capacities, and Electric Details	
Flow Range	0-40 GPM
Required Inlet Pressure	5 PSI
Pressure Boost	Up to 60 PSI boost. Standard Max. outlet 80 PSI, optional high pressure outlet 100 PSI.
Electrical Requirements	230 V, 1-PH, 60 Hz
Max. Operating Amps	12
Electric/Control	NEMA 4 rated electrical termination housing. Pump includes, motor, variable speed drive, pressure switch, and overtemp switch.

PERFORMANCE

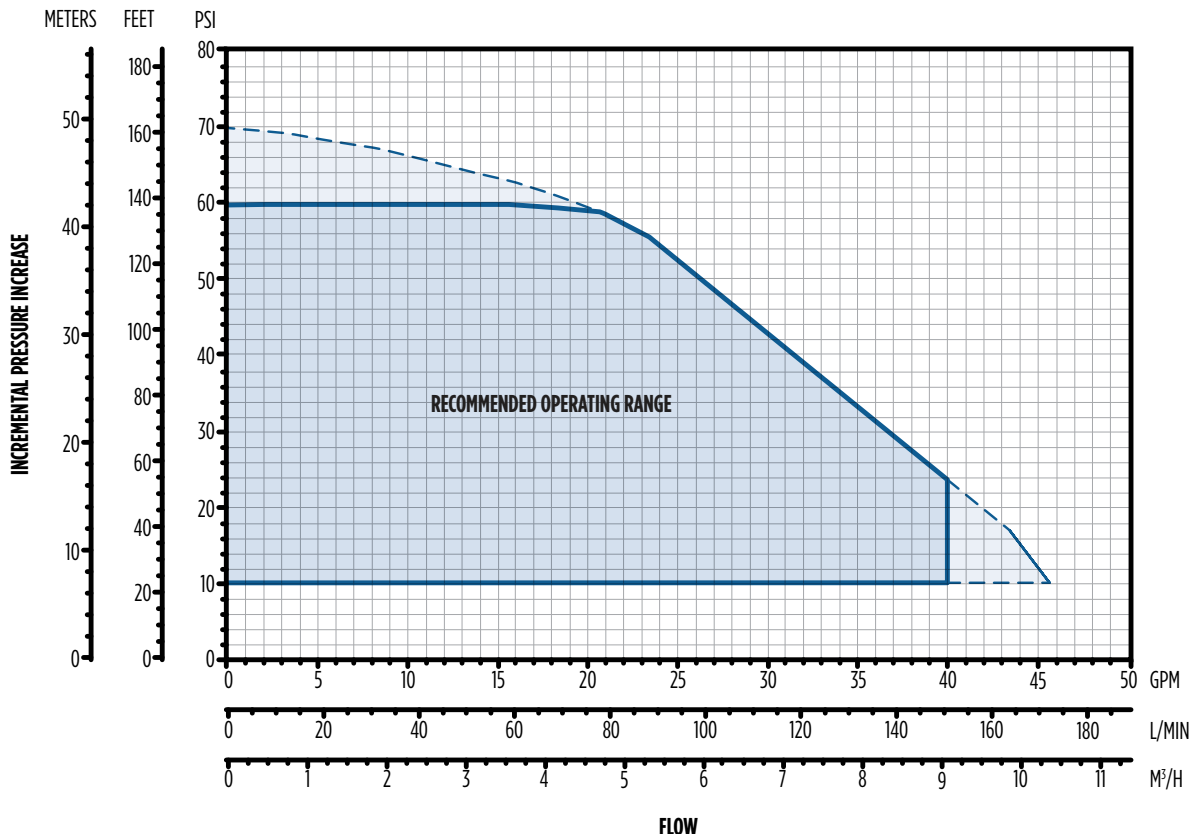

NOTE: Running outside of 'Recommended Operating Range' for short periods of time is permissible



INLINE 1100 DUPLEX W/ALTERNATOR SPECPAK

DIMENSIONS & SPECIFICATIONS

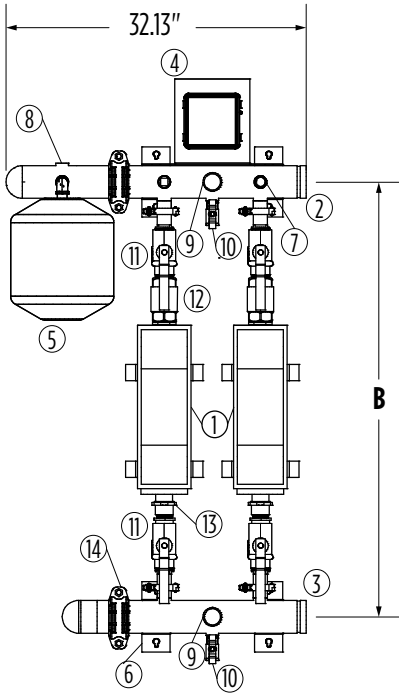

FRONT VIEW

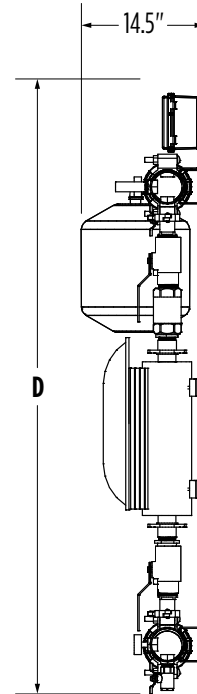

SIDE VIEW

Version (see pg. 3)	Manifold Distance - B	Overall Height - D
Standard	44-3/16"	64-1/2"
With Suction-Side Check Valve Included	49-1/2"	67-1/8"

Ratings, Capacities, and Electric Details	
Flow Range	0-80 GPM
Required Inlet Pressure	2-5 PSI
Discharge Pressure	Up to 60 PSI boost (Max. Output of 80 PSI total)
Electrical Requirements	230 V, 1-PH, 60 Hz
Max. Operating Amps	24
Control Panel Items	SubDrive duplex alternator panel equipped with transformer and 120 V electrical cord (for power control)

Connections and Major Component List		
No.	Part Name	Description
1	Franklin Electric Inline 1100 Variable Speed Pump	304 SS/316 SS
2	Discharge Connection	3" grooved DIA. threaded male connection - 304 SS
3	Inlet Connection	3" grooved DIA. threaded male connection - 304 SS
4	Control/Electrical Panel 5.80" x 7.35" x 3.60"	SubDrive Duplex Alternator
5	Pressure Tank	4.8 gal tank with rubber bladder
6	Mounting Frame	304 SS 12 gauge, 4-frame pieces welded to manifolds
7	Pressure Switch	-
8	1-1/4" NPT Plugged Connection	304 SS, options include 2x2x1 and 2x2x 1-1/2 female THD tees
9	Pressure Gauge	-
10	Drain Valve	3/4" SS drain valve
11	Isolation Valve	1-1/2" SS full port ball valve
12	Check Valve	1-1/2" SS inline spring check valve
13	Pump Connection	1-1/4" 150# oval flange - 304 SS
14	Header Couplings	3" Grooved couplings

INLINE 1100 DUPLEX SPECPAK

DIMENSIONS & SPECIFICATIONS

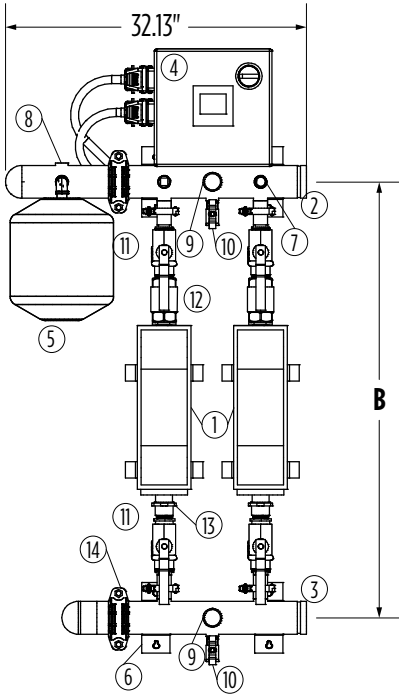

FRONT VIEW

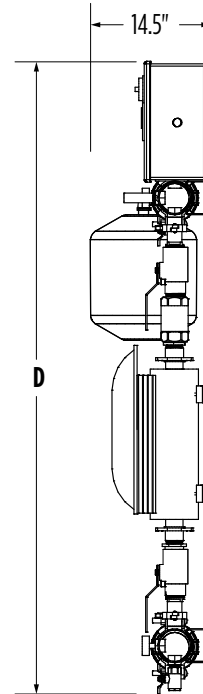

SIDE VIEW

Version (see pg. 3)	Manifold Distance - B	Overall Height - D
Standard	44-3/16"	64-1/2"
With Suction-Side Check Valve Included	49-1/2"	69-7/8"

Ratings, Capacities, and Electric Details	
Flow Range	0-80 GPM
Required Inlet Pressure	2-5 PSI
Discharge Pressure	Up to 60 PSI boost (Max. Output of 100 PSI total)
Electrical Requirements	230 V, 1-PH, 60 Hz
Max. Operating Amps	26.5A
Control Panel Items	Lockable disconnect switch for entire package. Individual lockable disconnects for each pump. Color touchscreen plc. Fuses on incoming power, on power to each pump, and on plc.

Connections and Major Component List		
No.	Part Name	Description
1	Franklin Electric Inline 1100 Variable Speed Pump	304 SS/316 SS
2	Discharge Connection/HDR	Grooved connection 3" DIA. 3" DIA. SCH 10 304 SS
3	Inlet Connection/HDR	Grooved connection 3" DIA. 3" DIA. SCH 10 304 SS
4	Control/Electrical Panel 12" x 12" x 6"	Touch-screen HMI, lead/lag, alternating pump control
5	Pressure Tank	4.8 gal tank with rubber bladder
6	Mounting Frame	304 SS 12 gauge, 4 frame pieces welded to manifolds
7	Pressure Transducer	-
8	Capped 1-1/4" NPT Connection	For optional RV (provided by others)
9	Pressure Gauge	-
10	Drain Valve	3/4" SS drain valve
11	Isolation Valve	1-1/2" SS full port ball valve
12	Check Valve	1-1/2" SS inline spring check valve
13	Pump Connections	1-1/4" 150# oval flange - 304 SS
14	Header Couplings	3" Grooved couplings

INLINE 1100 TRIPLEX SPECPAK

DIMENSIONS & SPECIFICATIONS

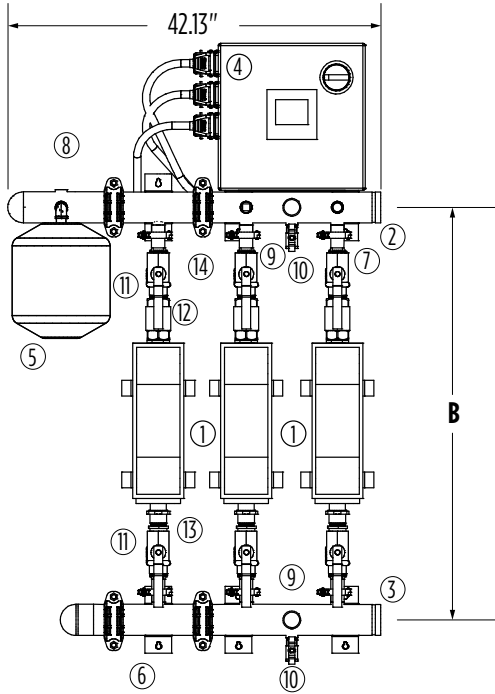

FRONT VIEW

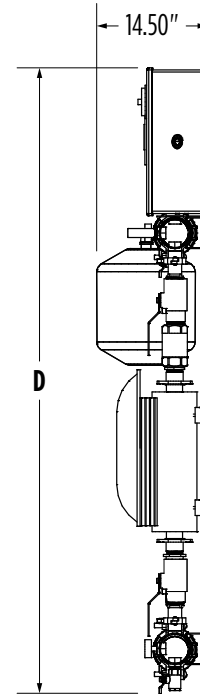

SIDE VIEW

Version (see pg. 3)	Manifold Distance - B	Overall Height - D
Standard	44-3/16"	68-1/2"
With Suction-Side Check Valve Included	49-1/2"	73-7/8"

Ratings, Capacities, and Electric Details	
Flow Range	0-120 GPM
Required Inlet Pressure	2-5 PSI
Discharge Pressure	Up to 60 PSI boost (Max. Output of 100 PSI total)
Electrical Requirements	230 V, 1-PH, 60 Hz
Max. Operating Amps	38.5A
Control Panel Items	Lockable disconnect switch for entire package. Individual lockable disconnects for each pump. Color touchscreen plc. Fuses on incoming power, on power to each pump, and on plc.

Connections and Major Component List		
No.	Part Name	Description
1	Franklin Electric Inline 1100 Variable Speed Pump	304 SS/316 SS
2	Discharge Connection	3" grooved 150# flange - 304 SS
3	Inlet Connection	3" grooved connection 150# flange - 304 SS
4	Control/Electrical Panel 16" x 16" x 6"	Touch-screen HMI, lead/lag, alternating pump control
5	Pressure Tank	4.8 gal tank with rubber bladder
6	Mounting Frame	304 SS 12 gauge, 6 frame pieces welded to manifolds
7	Pressure Switch	-
8	1-1/2" NPT Male Connection	For optional RV (provided by others)
9	Pressure Gauge	-
10	Drain Valve	3/4" SS drain valve
11	Isolation Valve	1-1/2" SS full port ball valve
12	Check Valve	1-1/2" SS inline spring check valve
13	Pump Connection	1-1/4" 150# flange - 304 SS
14	Header Couplings	3" Grooved couplings

INLINE 1100 QUAD SPECPAK

DIMENSIONS & SPECIFICATIONS

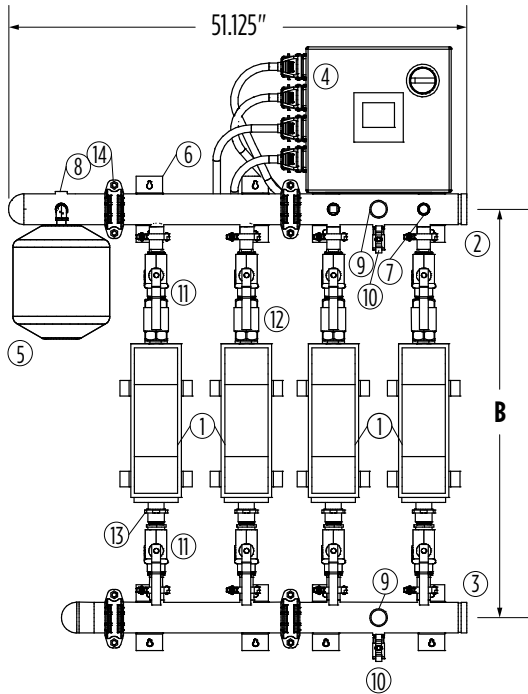

FRONT VIEW

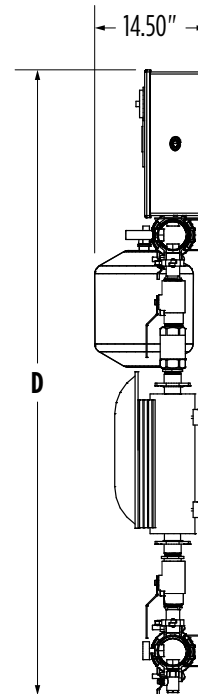

SIDE VIEW

Package ships in three different pieces (left side manifolds, right side manifolds, and control panel). The manifolds must be bolted together in the field as part of the installation process.

Version (see pg. 3)	Manifold Distance - B	Overall Height - D
Standard	44-3/16"	68-1/2"
With Suction-Side Check Valve Included	49-1/2"	73-7/8"

Ratings, Capacities, and Electric Details	
Flow Range	0-160 GPM
Required Inlet Pressure	2-5 PSI
Discharge Pressure	Up to 60 PSI boost (Max. Output of 100 PSI total)
Electrical Requirements	230 V, 1-PH, 60 Hz
Max. Operating Amps	50.5A
Control Panel Items	Lockable disconnect switch for entire package. Individual lockable disconnects for each pump. Color touchscreen plc. Fuses on incoming power, on power to each pump, and on plc.

Connections and Major Component List		
No.	Part Name	Description
1	Franklin Electric Inline 1100 Variable Speed Pump	304 SS/316 SS
2	Discharge Connection	3" grooved 150# flange - 304 SS
3	Inlet Connection	3" grooved 150# flange - 304 SS
4	Control/Electrical Panel 16" x 16" x 6"	Touch-screen HMI, lead/lag, alternating pump control
5	Pressure Tank	4.8 gal tank with rubber bladder
6	Mounting Frame	304 SS 12 gauge, 8 frame pieces welded to manifolds
7	Pressure Switch	-
8	Capped 1-1/2" NPT Male Connection	For optional RV (provided by others)
9	Pressure Gauge	-
10	Drain Valve	3/4" SS drain valve
11	Isolation Valve	1-1/2" SS full port ball valve
12	Check Valve	1-1/2" SS inline spring check valve
13	Pump Connection	1-1/4" 150# flange - 304 SS
14	Header Couplings	3" Grooved couplings



ACCESSORIES - INLINE 1100 SPECPAK

TRANSFORMERS

Order No.	Application	Type	Primary / Secondary	kVA	Taps	Temp Rise (°C)	Electrostatic Shield	Dimensions (in)			Wt. (lbs)	Wall Mount Bracket	Wiring Diagram
								H	W	D			
305619011	480 V Supply to 240 V for Simplex/Duplex	Encapsulated	240x480 V- 120/240 V	7.5	None	115	No	15.00	13.19	13.13	150	Built-in	A
305619012	480 V Supply to 240 V for Triplex	Encapsulated	240x480 V- 120/240 V	10	None	115	No	17.00	13.19	13.13	175	Built-in	A
305619013	480 V Supply to 240 V for Quad	Encapsulated	240x480 V- 120/240 V	15	None	115	No	17.00	13.19	13.13	270	Built-in	A
305619014	208 V Supply to 240 V for Simplex/Duplex	Encapsulated	208 V - 120/240 V	7.5	-2@5%	115	No	15.00	10.19	10.63	150	Built-in	B
305619015	208 V Supply to 240 V for Triplex	Encapsulated	208 V - 120/240 V	10	-2@5%	115	No	17.00	13.19	13.13	175	Built-in	B
305619016	208 V Supply to 240 V for Quad	Encapsulated	208 V - 120/240 V	15	-2@5%	115	No	17.00	13.19	13.13	270	Built-in	B

Diagram A		
Primary Voltage	Secondary Voltage	Taps
240 x 480	120/240	None
Primary		
Secondary		
Volts	Connections	Line Leads
480	H2 - H3	H1, H4
240	H1 - H3, H2 - H4	H1, H4
240	X2 - X3	X1, X4
240/120	X2 - X3	X1, X2, X4
120	X1 - X3, X2 - X4	X1, X4

Diagram B		
Primary Voltage	Secondary Voltage	Taps
208	120/240	-2@5%
Primary		
Secondary		
Volts	Connections	Line Leads
208	-	H1, H4
198	-	H1, H3
187	-	H1, H2
240	X2 - X3	X1, X4
240/120	X2 - X3	X1, X2, X4
120	X1 - X3, X2 - X4	X1, X4

PLUMBING & PRODUCT EXTENSIONS

Order No.	Description
305619000	Duplex Discharge Header
305619001	Duplex Suction Header
305619002	Assembled Bladder Header
305619003	Assembled Suction Header End Cap
305619004	3" Victaulic #107N Rigid Coupling, Galvanized with E Gasket (NSF 61 Certified)
305619005	Pump Piping Circuit
305619007	Triplex Header Suction and Discharge (Adds 1 Pump Circuit to Duplex)
305619008	III100 Triplex Pump Package Control Panel, Pressure Transducer Control - NEMA 1
305619009	Quad Header Suction and Discharge (Adds 2 Pump Circuits to Duplex)
305619010	III100 Quad Pump Package Control Panel, Pressure Transducer Control - NEMA 1
305619022	3" Victaulic Flange Adapter, Black

COMMUNICATION CARDS

Order No.	Description
305619017	Modbus Card
305619018	Ethernet Card

MOUNTING & ISOLATION SYSTEM FOR WALLS

Order No.	Description
305619020	Duplex/Triplex Kinetics Isolator Kit (Includes (4) 3' Long Furring Strips, (8) Isolator Clips, (8) 1/4X1" Tek Screws)
305619021	Quadruplex Kinetics Isolator Kit (Includes (8) 3' Long Furring Strips, (16) Isolator Clips, (16) 1/4X1" Tek Screws)

