

**MYERS®****MWH50 - MW200 Series****ME50 - ME150 Series****Single and double seal. Single and three phase power.**

**Single Seal Pump**  
**ME50S, ME75S**  
**ME100S, ME150S,**  
**MWH50, MW100,**  
**MW150, MW200**

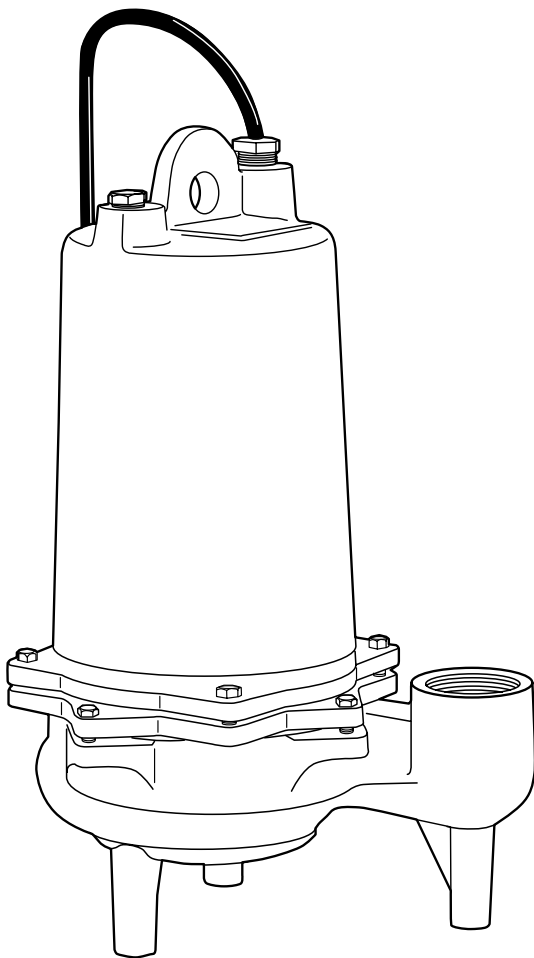
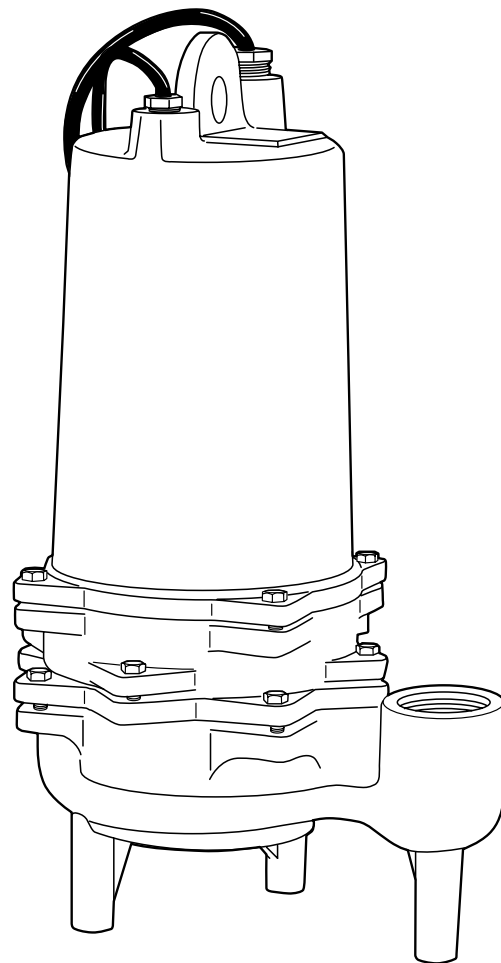

**Double Seal Pump**  
**ME50D, ME75D**  
**ME100D, ME150D,**  
**MWH50D, MW100D,**  
**MW150D, MW200D**

# Typical Section Drawing For ME/MW50-200 Single Seal Pumps

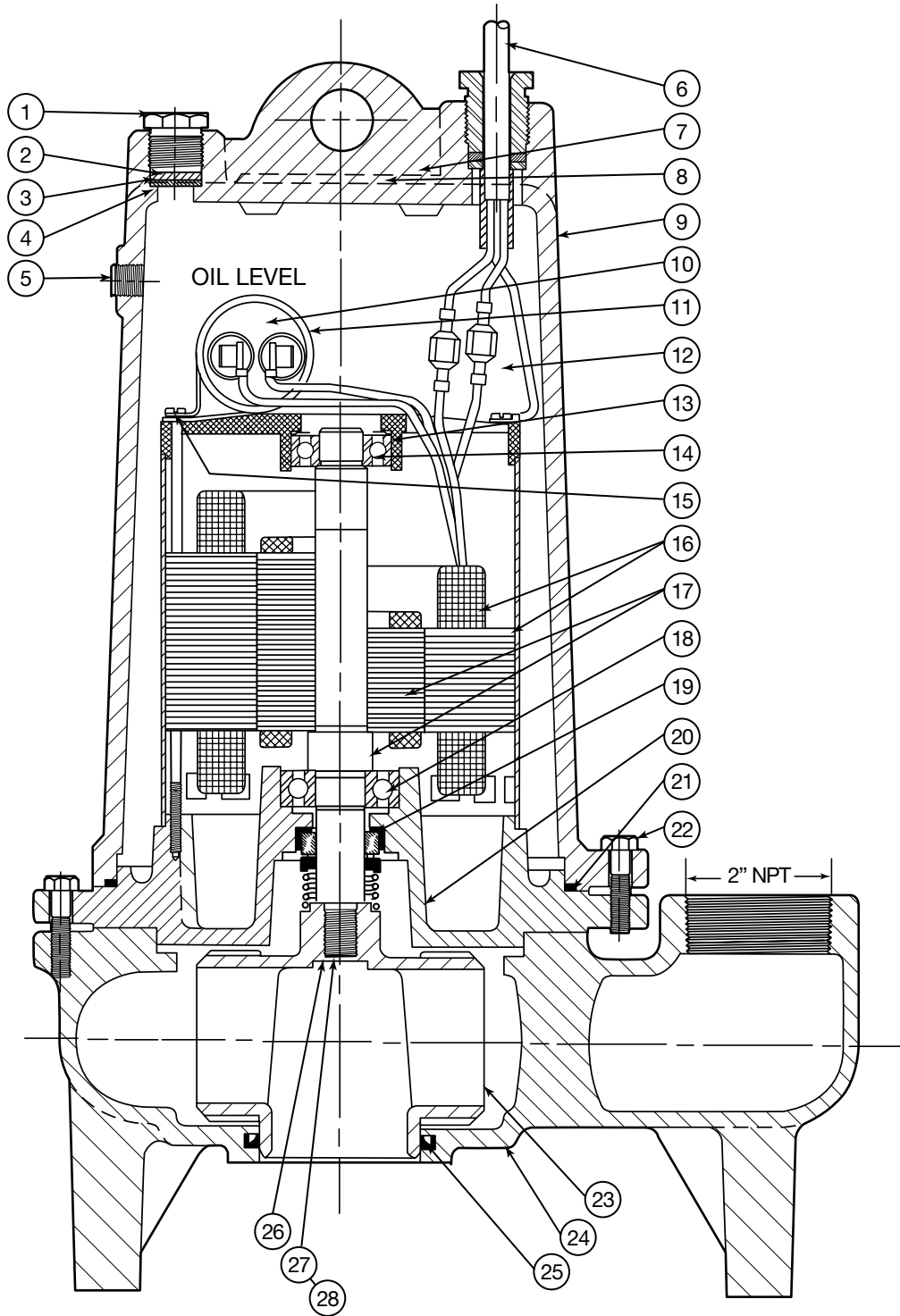

## Single Seal Repair Parts List

Ref.	Description	Qty.	Part Numbers
1	Nut, cord plug, solid	1	25341A002
2	Washer, 1/32" Thk.	1	05030A234
3	Gasket, Rubber	1	05014A193
4	Washer, 3/32" Thk.	1	05030A235
5	Plug, 1/4" pipe	1	05022A009
6	Cord, Power	1	See Chart
7	Screw, drive	2	05160A004
8	Name Plate	1	N/A
9	Housing, Motor	1	25327D000
10	Capacitor (1Ph only)	1	See Chart
11	Clip, capacitor (1 Ph only)	1	See Chart
12	Oil, Transformer	.8-1 gal	11009A006
12A	Connectors (3 Ph only)	3-6	15781A001
13	Washer, bearing	1	19331A005
14	Bearing, ball, upper	1	08565A013
15	Screw, st, #10 x 3/8	2	09822A032

Ref.	Description	Qty.	Part Number
16 & 17	Stator, Rotor shaft with shell	1	See Chart
18	Bearing, ball, lower	1	08565A022
19	Seal, shaft	1	25370A000
20	Plate, brg & seal	1	25367D000
21	Gasket, tetraseal, 7x6-3/4x1/8	1	05014A181
22	Screw, cap, 5/16 x 1-1/4	8	19100A012
23	Impeller	1	See Chart
24	Case, volute (ME50)	1	25357D000
	Case, volute (ME75-150)	1	25331D000
	Case, volute (MWH5-200)	1	26057D000
25	Cup, U, HUVA (ME50-150)	1	22835A005
	Cup, U, HUVA (MWH50-200)	1	22835A009
26	Washer, Impeller Retainer	1	05030A242
27	Screw, Machine #10 x 3/8	1	06106A042
28	Sealant	1	14550A001

Unit manufactured prior to Aug-2007 contact factory for repair parts.

Item Number			6		10	11	16 & 17	23			
HP	Volts	PH	Power Cord W/Plug	Power Cord No Plug	Capacitor	Capacitor Clip	Stator Rotor & Shaft Ass'y	ME Impeller Plastic	ME Impeller Brass	MWH Impeller DI	MWH Impeller Brass
1/2	115	1	25338B004	25338B006	23839A000	20333A006	25484D100	25333B025	25348B121	26029B013	26029B113
	208	1									
	230	1	25338B005								
	208	3									
	230	3									
	460	3									
3/4	115	1	25338B000	25338B002	23839A000	20333A006	25484D100	25348B020	25348B120		
	208	1									
	230	1	25338B001								
	208	3									
	230	3									
	460	3									
1	208	1		25338A002	23838A000	20333A004	25484D104	25348B010	25348B110	26029B012	26029B112
	230	1	25338B001								
	208	3									
	230	3									
	460	3									
	575	3									
1-1/2	208	1		25338B002	23838A000	20333A004	25484D104	25348B000	25348B100	26029B011	26029B111
	230	1	25338B001								
	208	3									
	230	3									
	460	3									
	575	3									
2	208	1		25338B009	23839A000	20333A006	25484D108			26029B000	26029B100
	230	1			26520A000						
	208	3									
	230	3									
	460	3									
	575	3									

# Typical Section Drawing For ME/MW50-200 Double Seal Pumps

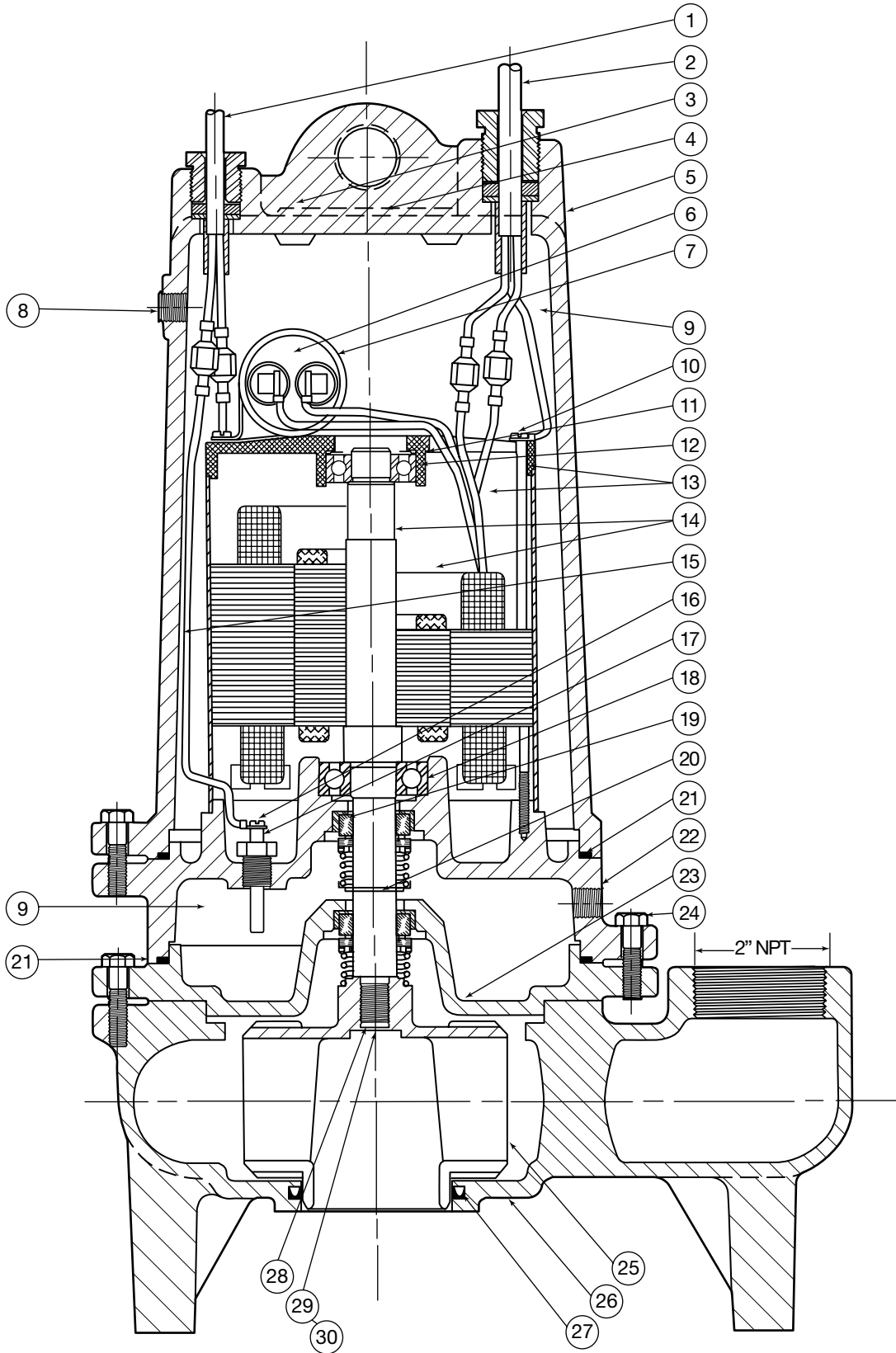

## Double Seal Repair Parts List

Ref.	Description	Qty.	Part Number
1	Cord, Sensor	1	25339B000
2	Cord, Power	1	See Chart
3	Screw, drive	2	05160A004
4	Name Plate	1	N/A
5	Housing, Motor	1	25327D000
6	Capacitor (1Ph only)	1	See Chart
7	Clip, capacitor (1 Ph only)	1	See Chart
8	Plug, 1/4" pipe	1	05022A009
9	Oil, Transformer	1.12 gal	11009A006
9A	Connectors (3 Ph only)	3-6	15781A001
10	Screw, st, #10 x 3/8	2	09822A032
11	Washer, bearing	1	19331A005
12	Bearing, ball, upper	1	08565A013
13 & 14	Stator, Rotor shaft with shell	1	See Chart
15	Wire, electrode	2	21792A004
16	Screw, #6 x 1/4	2	05434A025
17	Seal Probe	2	25343A000

Ref.	Description	Qty.	Part Number
18	Bearing, ball, lower	1	08565A022
19	Seal, shaft	1	25370A000
20	Ring, retaining	2	12558A021
	Ring, retaining	1	12558A033
21	Gasket, tetraseal, 7x6-3/4x1/8	2	05014A181
22	Housing seal	1	25369D000
23	Plate, bottom	1	25368D000
24	Screw, cap 5/16 x 1-1/4	12	19100A012
25	Impeller	1	See Chart
26	Case, volute (ME50)	1	25357D000
	Case, volute (ME75-150)	1	25331D000
	Case, volute (MWH50-200)	1	26057D000
27	Cup, U, HUVA (ME50-150)	1	22835A005
	Cup, U, HUVA (MWH50-200)	1	22835A009
28	Washer, Impeller Retainer	1	05030A242
29	Screw, Machine #10 x 3/8	1	06106A042
30	Sealant	1	14550A001

Unit manufactured prior to Aug-2007 contact factory for repair parts.

Item Number			2	6	7	13 & 14	25					
HP	Volts	PH	Power Cord W/Plug	Power Cord No Plug	Capacitor	Capacitor Clip	Stator Rotor & Shaft Ass'y	ME Impeller Plastic	ME Impeller Brass	MWH Impeller DI	MWH Impeller Brass	
1/2	115	1	25338B004	25338B006	23839A000	20333A006	25484D200	25333B025	25348B121	26029B013	26029B113	
	208	1					25484D201					
	230	1	25338B005									
	208	3		25484D202								
	230	3	25338B003									
	460	3										
575	3											
3/4	115	1	25338B002	25338B002	23839A000	20333A006	25484D200	25348B020	25348B120			
	208	1					25484D201					
	230	1	25338B001									
	208	3		25484D202								
	230	3	25338B003									
	460	3										
575	3											
1	208	1		25338B002	23838A000	20333A004	25484D204	25348B010	25348B110	26029B012	26029B112	
	230	1	25338B001				25484D205					
	208	3					25484D206					
	230	3	25338B003									
	460	3										
	575	3										
1-1/2	208	1		25338B002	23838A000	20333A004	25484D204	25348B000	25348B100	26029B011	26029B111	
	230	1	25338B001				25484D205					
	208	3					25484D206					
	230	3	25338B003									
	460	3										
	575	3										
2	208	1		25338B009	23839A000	20333A006	25484D208			26029B000	26029B100	
	230	1			26520A000		25484D209					
	208	3		25338B008								25484D210
	230	3										25484D211
	460	3	25338B003									
	575	3										

---

## Important Safety Instructions

**SAVE THESE INSTRUCTIONS** - This manual contains important instructions that should be followed during installation, operation, and maintenance of the product. Save this manual for future reference.

**▲** This is the safety alert symbol. When you see this symbol on your pump or in this manual, look for one of the following signal words and be alert to the potential for personal injury!

**▲ DANGER** indicates a hazard which, if not avoided, *will* result in death or serious injury.

**▲ WARNING** indicates a hazard which, if not avoided, *could* result in death or serious injury.

**▲ CAUTION** indicates a hazard which, if not avoided, *could* result in minor or moderate injury.

**NOTICE** addresses practices not related to personal injury.

**▲ WARNING Risk of electric shock.** Pumps with a single seal are supplied with a grounding conductor and grounding-type attachment plug on the power cord. To reduce the risk of electric shock:

- Be certain that it is connected only to a properly grounded, grounding-type receptacle.
- DO NOT cut off ground pin or use an adapter fitting.
- DO NOT use an extension cord with this pump.
- Entire plug may be cut off if a control panel is used.
- All double seal pumps, all duplex installations and all three phase pumps require a control box.
- When wiring this pump follow all local electrical and safety codes and ordinances as well as the most recent National Electric Code (NEC-ANSI/NFPA 70).

All pumps have a GROUND WIRE that is connected to a screw in the metal motor housing. This wire goes to the receptacle or control box which must be connected to a good outside GROUND such as a metal water pipe or GROUND STAKE driven at least 8 feet into the ground.

**When overload current protection is provided by installer:**

USE WITH APPROVED MOTOR CONTROL THAT MATCHES MOTOR INPUT IN FULL LOAD AMPERES WITH OVERLOAD ELEMENT(S) SELECTED OR ADJUSTED IN ACCORDANCE WITH CONTROL INSTRUCTIONS.

**When motor has built-in overload protection:**

USE WITH APPROVED MOTOR CONTROL THAT MATCHES MOTOR INPUT IN FULL LOAD AMPERES.

**California Proposition 65 Warning**

**▲ WARNING** This product and related accessories contain chemicals known to the State of California to cause cancer, birth defects or other reproductive harm.

## General Description and Application

Myers ME and MW series pumps are available in both a single seal design and double seal design with leak detector. The ME50-ME150 models are designed for Effluent dosing, Septic Tank Effluent Pumping (S.T.E.P.) or normal sump and general dewatering applications where higher pressure is required. These units are designed to handle ¾" spherical solids. The MWH50-MW200 models are designed for raw sewage applications and can pass 2" spherical solids. These units can also be used for sump and general dewatering applications where larger solids capabilities are required.

When used in Effluent dosing or S.T.E.P. applications, the pump must be installed in a separate tank or compartment at the discharger side of the septic tank.

**Never install pump in tank where sludge collects.**

These pumps are available in single phase and three phase, and either in single seal or double seal with seal leak detector. All three phase units, all double seal units and all duplex installations must be used with a control box. All power cords and seal leak detector cords are 20 feet long.

The ME model impellers are enclosed two vane type to handle ¾" spherical solids and are available made of engineered thermoplastic or cast brass. All pumps have a 2" NPT discharge tapping.

The MW model impellers are enclosed two vane non-clog style, designed to handle 2" spherical solids. The MW pumps are available with standard cast iron or optional cast brass impellers.

These pumps are NOT for use in swimming pools or fountains.

### Air Locking

A sump pump is said to be air locked if water traps air in the pump and it cannot get out, thus preventing the pump from operating.

In installation of this type a 1/8" hole should be drilled in the discharge pipe just above the pump discharge. The check valve should be 12 to 18 inches above pump discharge. Do not put check valve directly into pump discharge opening. - follow local code.

### Packaging

Each pump is packaged separately in a carton marked with a catalog number and Myers engineering number.

### Level Controls

All pumps must use sealed level control switches for automatic operation. MLC and MFLC controls have sealed switches that are 1 HP rated at 230 volts. ALC and AWS-1 controls have sealed mechanical switches that are rated 2 HP at 230 volts.

---

Simplex single phase pumps can be made automatic by attaching MFLC or MLC controls to the pump. These switches have a fixed draw off level of 8 to 10 inches and can be used up to 1 HP. For higher horsepower ratings two mercury switches (or SMNO) controls with a magnetic starter can be used. Simplex systems may also use on/off pilot mercury control switches (when permitted by code) with control box and magnetic starter. The ALC and AWS-1 controls can be used for simplex single phase pumps with ratings up to 2 HP. All duplex systems must use pilot mercury control switches with control box and magnetic starters. Plug-in cords can be used on all the single phase pumps with a single seal (does not have a seal leak detector). This cord has a GROUND pin that plugs into a grounded receptacle. The grounded receptacle cannot be used in the wet sump or basin due to DANGER of current leakage. Sealed junction boxes must be used in wet sumps or basins to make connections to motor cord. The AWS-1 control also acts as a sealed junction box for connecting power cord to pump cord.

### **Double Seal Pumps**

All pumps in this series “ME—D” or “MW—D” have two seals with an oil chamber between the seals so that the seal faces of both the lower and upper seals are oil lubricated for longer life and greater protection against water leaking into the motor windings. These double seal units are all made with a seal leak detector.

The leak detector in the oil seal chamber detects any water leakage into the chamber and turns on a red signal light in the control panel. Pumps should be removed from the sump and seals replaced after the seal light shows in the panel. Control panels must be used for pumps having the seal leak detectors, and seal leak detectors must be wired as illustrated in these instructions.

### **Design Of Pressure Sewer Systems**

MYERS has available complete computer SOFTWARE for designing PRESSURE SEWER SYSTEMS. This gives pipe sizes to use and gives exact flow from any pump or group of pumps in the system when operating simultaneously. This design DISK for IBM or COMPATIBLE computers is available to engineers on request.

### **Motor Type**

Motors are ¾ frame, 1/3 – 2HP single or three phase, 60 Hertz, 3450 R.P.M. with class B insulation. All single phase motors are permanent split-capacitor (PSC) type with built-in on-winding overload protection and do not require a start switch or start relay. The three phase pump motors require a magnetic starter with 3 leg overload protection. All motors have upper and lower ball bearings and all are oil-cooled and lubricated.

## **Installation**

**▲ WARNING Breathing hazard.** Basin or tank must be vented in accordance with local plumbing codes. These pumps are not designed for and CANNOT be installed in locations classified as hazardous in accordance with the National Electric Code ANSI/NFPA 70.

- Never enter pump chamber after sewage or effluent has been in basin. Sewage water can give off methane, hydrogen sulfide and other gases which are highly poisonous.

Myers recommends installing ME series effluent pumps with a quick removal system. The quick removal system may be a union or quick-release coupling if the pipe or discharge hose is within reach from the surface, or a rail system type quick disconnect on deeper installations. See installation drawings for suggested installation.

The dosing tank or pumping chamber must be constructed of corrosion resistant materials and must be capable of withstanding all anticipated internal and external loads. It also must not allow infiltration or exfiltration. The tank must have provisions for anti-buoyancy. Access holes or covers must be of adequate size and be accessible from the surface to allow for installation and maintenance of the system. Access covers must be lockable or heavy enough to prevent easy access by unauthorized personnel. The pumping chamber holding capacity should be selected to allow for emergency conditions.

The discharge pipe must be the same size as the pump discharge (2 inches) or larger. In order to insure sufficient fluid velocity to prevent any residual solids from collecting in the discharge pipe, it is recommended that a minimum flow of 2 feet per second be maintained. (21 GPM through 2” pipe and 46 GPM through 3” pipe). It is recommended that PVC or equal pipe is used for corrosion resistance. A full flow (ball or gate) shut off valve must be installed to prevent back flow of effluent if the pump must be removed for service. A check valve must be installed on pressure sewer systems and on other systems where conditions allow to prevent backflow and to reduce wear on the pump system.

A high water alarm must be installed on a separate circuit from the pump circuit. The alarm should have the ability to be tested for proper operation.

---

## Special Instructions For Three Phase Pumps

- (1) Myers recommends three phase pumps to be installed by qualified personnel.  
**⚠ WARNING Risk of electric shock.** Do not remove cord and strain relief. Do not connect conduit to pump.
- (2) Three phase pumps are always installed with control boxes having magnetic starters with 3 leg overload protection. **DO NOT TRY TO RUN THREE PHASE PUMPS DIRECTLY ACROSS THE LINE.**
- (3) **To Connect Pump:** Run wire from pump to the bottom of control box or appropriate junction box suitable for enclosing splice connections. A hole must be cut into the control box for the wires. With power to control box off, connect green (ground) line to ground lug. Connect black (power) wires to power lead terminals. **Note:** for a typical CE style control box, these terminals are marked M1, M2 and M3. Make sure that all wires are inside control box and not in a position to be pinched or shorted when the door is closed.
- (4) All three phase motors can run either direction. **ROTATION** can be changed by interchanging any two line leads at magnetic starter. **BE SURE CIRCUIT BREAKER IS OFF BEFORE MAKING THIS CHANGE.** To find if rotation is correct operate pumps and check delivery operation. If flow and head is low (refer to pump curves shown in this manual) the rotation is wrong. With duplex pumps, check operation of both pumps.
- (5) All pump impellers, either single or three phase, must turn counterclockwise when looking into pump inlet. If uncertain of rotation, **TURN OFF POWER** and lift pump from basin with cord connected and lay pump on side so impeller can be seen. Turn on power and start pump using hand position of H-O-A switch. Turn on and off fast so that coast of impeller can be seen. **NEVER PUT HAND OR FINGERS ON THE IMPELLER.** Interchange any two I line leads at the magnetic starter to change rotation.

## Points To Check If Pump Does Not Run Or Does Not Run Properly

- (1) Pump does not run or start when water is up in tank.
  - (a) Check for blown fuse or tripped circuit breaker.
  - (b) Check for defective level switch.
  - (c) Where control panel is used be sure H-O-A switch is in the AUTO position. If it does not run, turn switch to the HAND position and if the pump runs then the trouble is in the automatic electrical system. Have an **ELECTRICIAN** make electrical checks.
  - (d) Check for burned out motor. Occasionally lightning can damage a motor even with lightning protection.
  - (e) Where plug-in cords are used, be sure contact blades are clean and making good contact. **DO NOT USE PLUG-IN CORDS INSIDE A SUMP OR WET WELL.**
  - (f) Level control ball or weight may be stuck on side of basin. Be sure it floats freely.
- (2) Pump runs but does not deliver flow.
  - (a) Check air lock. Start and stop pump several times; if this does not help it may be necessary to loosen a union in the discharge line to relieve air lock.
  - (b) Check valve may be installed backwards. Check flow arrow on valve body. Check shut-off valve. It may be closed.
  - (c) Check vertical elevation. It may be higher than pump can develop. (See pump curve).
  - (d) Pump inlet may be plugged. Remove pump to check.

**⚠ WARNING Risk of electric shock.** Always unplug power cords or turn off all main and branch circuit breakers before doing any work on the pump. If control panel is remote from pump, disconnect lead wires to motor so that no one can turn the circuit breaker back on. If motor is three phase, mark the leads so they can be replaced in the same order.

## Before Dismantling Pump For Replacement Of Parts

Clean pump thoroughly. Knock off all scale and deposits. Use sandblast if possible. Submerge complete unit in dilute bleach solution for one hour before disassembly.



## 30" Diameter Simplex ME/MW 1/3 - 2 HP

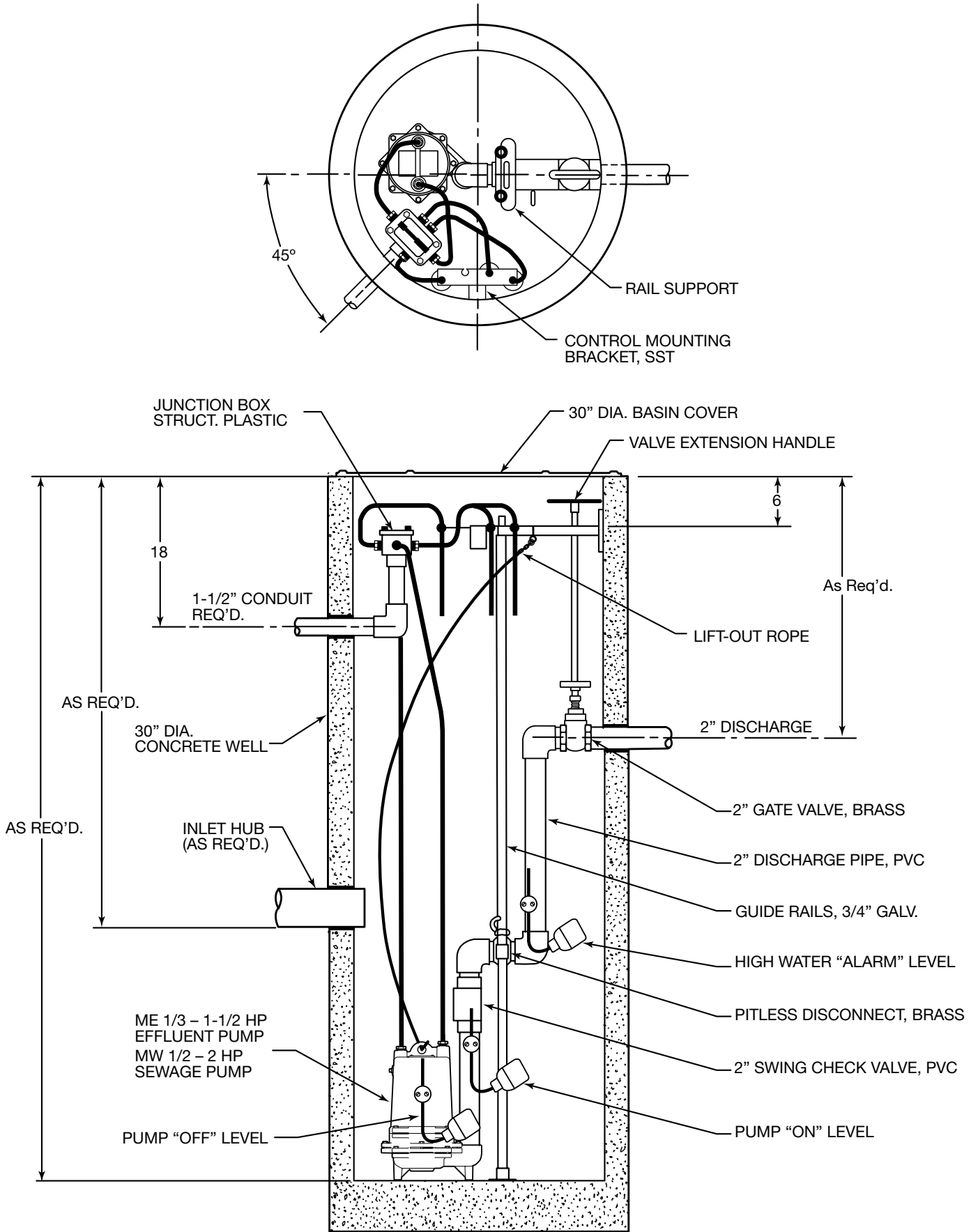

# 30" Diameter Simplex Union System ME/MW 1/3 - 2 HP

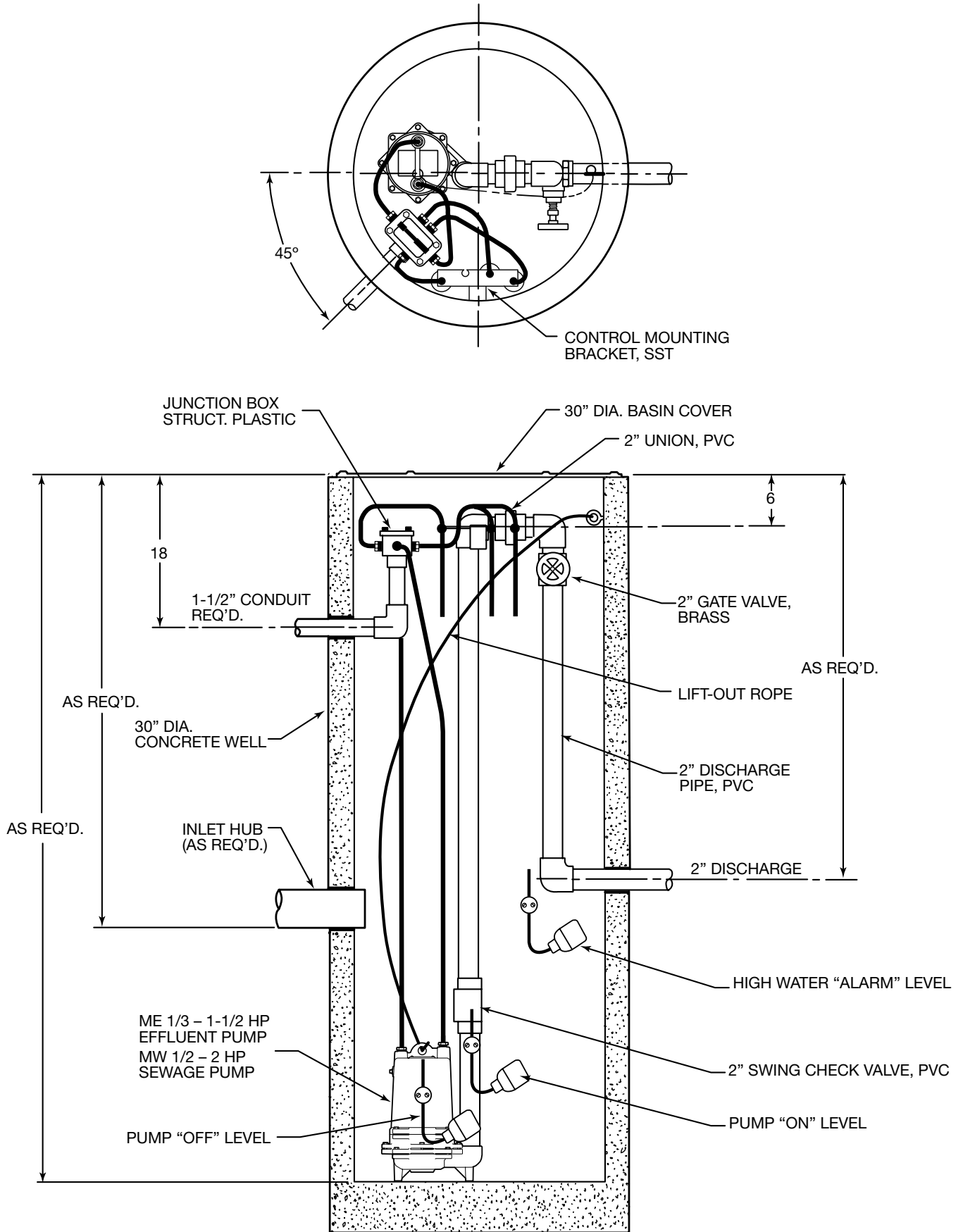

## 48" Diameter Duplex ME/MW 1/3 - 2 HP

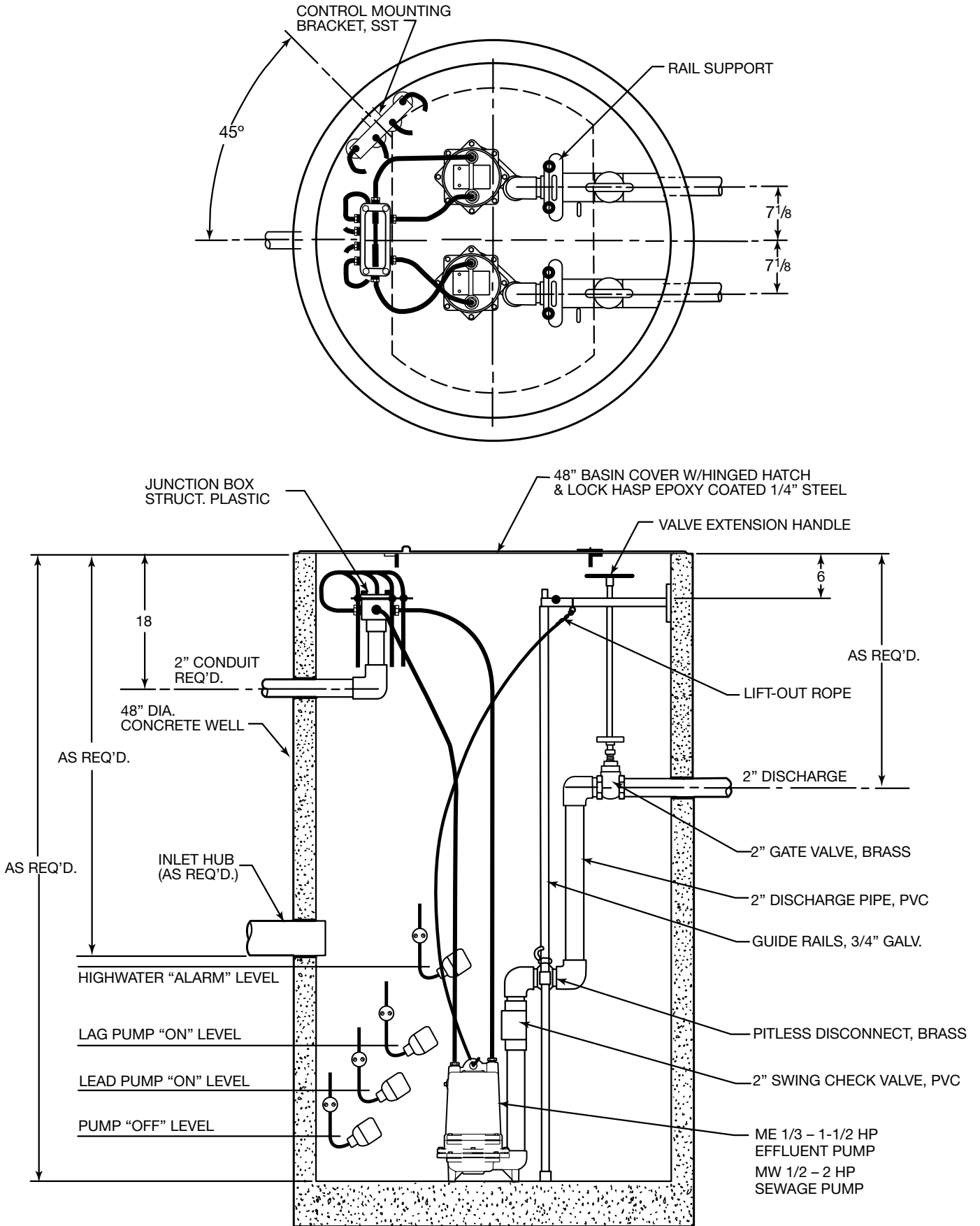

## To Replace Capacitors Only

All of the single phase motors are of the permanent split capacitor type and have no relays or starting switch. They have only a starting capacitor that is in the circuit for both starting and running conditions.

- (1) Remove oil fill plug near the top of the motor and pour the oil out.
- (2) Loosen the pug nuts around the cords until they are loose enough to push the cords down inside of the motor housing.
- (3) Remove the four bolts from the motor housing and bump the housing with a plastic hammer to loosen. Lay the pump on its side.
- (4) Remove the housing carefully to be sure that enough cord is pushed into the housing to create no tension on the cords.
- (5) Slide motor housing up far enough to expose the capacitor and to be able to lay the housing down.

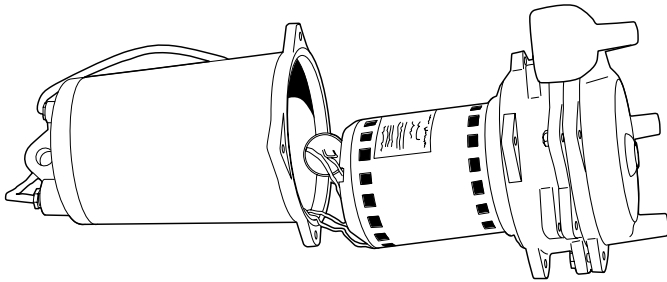

- (6) Disconnect wiring from capacitor and loosen capacitor clamp and slide out capacitor. Replace with new capacitor, tighten and re-connect. Wiring diagram is given in these instructions.
- (7) Check all wiring connectors to be sure they are secure.
- (8) Be sure tetraseal gasket is in place.
- (9) Slide motor housing back onto pump while pulling the cords out slowly. Assemble the motor housing with the four bolts.
- (10) Re-assemble cord nuts. Be sure washers are seated and cords are pulled up to stop against the washers. Tighten nuts securely.
- (11) Put pump upright and refill motor with refined paraffinic transformer oil, <sup>1</sup>Shellflex™ 2210 or equivalent. DO NOT OVER FILL WITH OIL. With pump upright fill oil to bottom of oil fill tapping. Replace oil fill plug.

<sup>1</sup> Shell Oil Company, Texas

- (12) Be sure pump turns freely before connecting to power. Turn pump on side and turn impeller, using screwdriver in slotted shaft. Plug pump into receptacle to test operation. Pump must run quiet and free of vibration.

## To Replace Power Cord And/Or Seal Leak Detector Cord

- (1) Remove motor housing as described above. Disconnect the push-together terminals and remove the ground screw from the power cord if being replaced.
- (2) Completely unscrew cord bushing to be replaced and remove cord assembly from housing. Be sure remaining terminals are secure on the wires.
- (3) Replace with proper cord with fittings. Push cord into the motor housing far enough to make proper connections. Reconnect ground wire if replacing power cord and securely connect the wires correctly. See wiring diagram in these instructions.
- (4) Assemble cords and motor housing as described in *Capacitor Replacement*. Fill with oil as noted and be sure pump turns freely before connecting to power.

## To Replace Motor Stator And Shell

- (1) Remove motor housing as described above.
- (2) Disconnect all leads from power and seal leak cords and ground wire and set pump upright.
- (3) Loosen the four long screw holding the motor and remove slowly. If unit has seal leak probes, be sure to feed the wires through the slots as the motor is being removed.
- (4) Either remove previous capacitor and clamp from old motor and assemble onto new stator and shell or replace with a new capacitor and assemble the two capacitor leads per wiring diagram.
- (5) Position bearing spring washer on top of upper ball bearing. (Fig. 1 -3 HP as shown in Figure 1).
- (6) Tighten terminal screws of seal leak probes and feed wires through the motor slots.

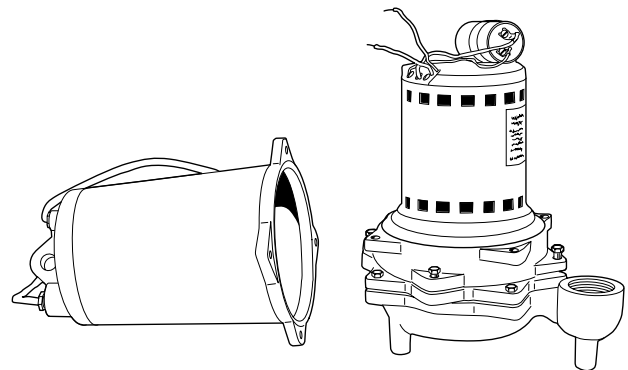

- (7) Position the "stator with shell" into place and line up screws with the bosses and tighten the (4) long screws. Extend probe wires out through the slots. Lay unit down in line with motor housing.
- (8) Be sure pump turns freely with screwdriver in impeller end of shaft.

- (9) Reconnect all terminals securely per wiring diagram.
- (10) Be sure tetraseal gasket is in place.
- (11) Reassemble motor housing and fill with oil as noted above in capacitor replacement.

**NOTICE** On three phase motors always check unit for proper rotation. With pump on its side apply power by turning on, then off, quickly. Impeller must turn counterclockwise when looking into the impeller inlet. If not, interchange any two leads in the control box.

## Shaft Seal Replacement

- (1) Remove plugs in motor housing and in seal housing (for double seal units) and drain oil.
- (2) Remove four bolts holding the volute case and bump with a plastic hammer to loosen and remove case.

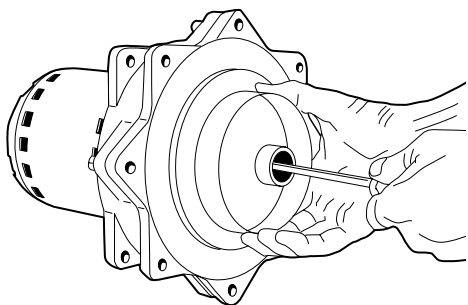

- (3) Hold impeller and unscrew impeller locking screw. Turn counterclockwise to loosen.
- (4) Pry off seal bellows and ceramic seat. Break seats if necessary to get out since they must be replaced with new parts.
- (5) NEVER USE OLD SEAL PARTS - USE ONLY COMPLETELY NEW SEALS. (Do not use seal spring retainer plate on single seal pump or lower seal of double seal pump.)
- (6) For single seal pumps or if only replacing the lower seal of a double seal pump, it is not necessary to disassemble further. On a double seal pump, it is not necessary to drain oil out of the motor housing, just the seal housing.
- (7) On a double seal pump, to remove the upper seal, remove four bolts holding the bottom plate and remove bottom plate.

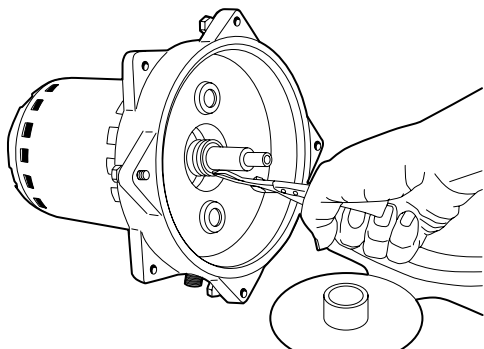

- (8) Remove snap ring with snap ring pliers. Pry off upper seal bellows and ceramic seat.
- (9) If no water has entered motor housing (check winding with ohmmeter or megger) wipe seal chambers thoroughly and replace seals. (Use seal retainer plate on upper seal only; do not use on lower seal.) Clean seal faces and use light on face before installing bellows part of seal.
- (10) Check HUVA cup seal in volute case inlet. If worn, replace.
- (11) Be sure tetraseal gasket is in position (replace if worn) and reassemble.
- (12) Replace oil in motor housing and seal chamber. Use only Myers submersible oil.
- (13) Be sure pump turns freely before connecting to power. After connecting, check for proper rotation noted under *Stator Replacement*.

## Wiring Diagram

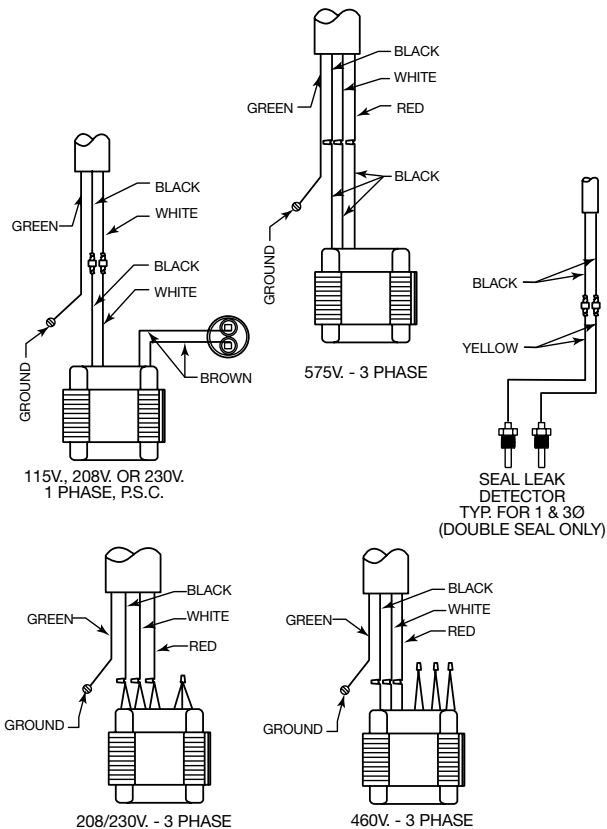

## 3 Phase Dual Voltage Winding

Voltage	Leads			
	Black	White	Red	Together
208 & 230	1 & 7	2 & 8	3 & 9	4 & 5 & 6
460	1	2	3	4 & 7, 5 & 8, 6 & 9

## Moisture Sensor Seal Probe Circuit

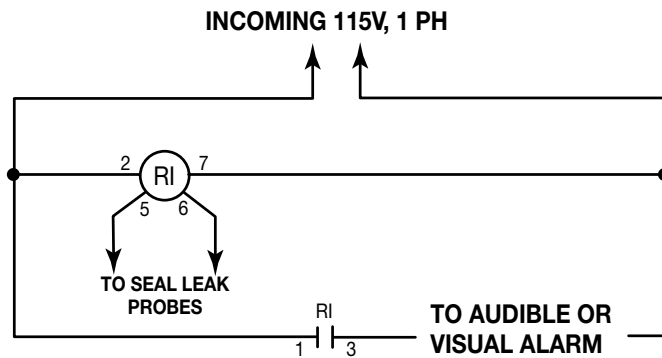

Relay: SSAC Inc. #LLC44A5A

Socket: Standard 8-pin plug-in type

If Myers panel is used see below.

Pumps: ME50D-11,  
ME75D-11

Required Panel:

CMEP(SL)-11S, -11SW,-11D, or -11DW

Pumps: ME50D-01, ME50D-21,  
ME75D-01, ME75D-21,  
ME100D-01, ME100D-21,  
ME150D-01, ME150D-21,  
MWH50D-01, MWH50D-21,  
MW100D-01, MW100D-21,  
MW150D-01, MW150D-21,  
MW200D-01, MW200D-21

Required Panel:

CMEP(SL)-21S, -21SW,-21D, or -21DW

Pumps: ME50D-03, ME50D-23,  
ME75D-03, ME75D-23,  
ME100D-03, ME100D-23,  
ME150D-03, ME150D-23,  
MWH50D-03, MWH50D-23,  
MW100D-03, MW100D-23,  
MW150D-03, MW150D-23,  
MW200D-03, MW200D-23

Required Panel:

CMEP(SL)-23S, -23SW,-23D, or -23DW

Pumps: ME50D-43,  
ME75D-43,  
ME100D-43,  
ME150D-43,  
MWH50D-43,  
MW100D-43,  
MW150D-43,  
MW200D-43

Required Panel:

CMEP(SL)-43S, -43SW,-43D, or -43DW

## ME Series Dimensions

Model Series	Inches (millimeters)			
	A	B	C	F
ME50S	16.8 (427)	4.09	1.03	12.13
ME50D	18.6 (472)	(104)	(26)	(308)
ME75S, ME100S, ME150S	16.8 (427)	4.0	1.06	12.5
ME75D, ME100D, ME150D	18.6 (472)	(102)	(27)	(318)

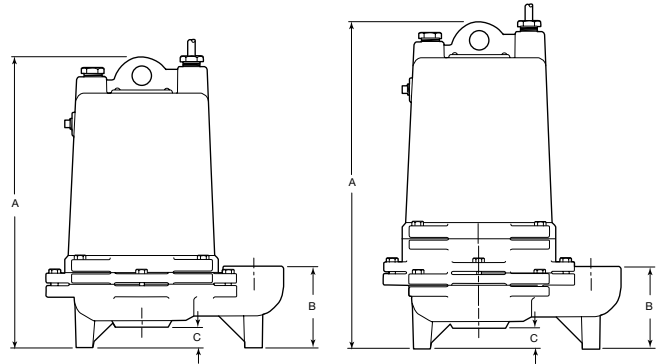
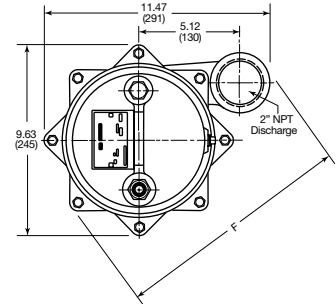

## ME Performance Curve

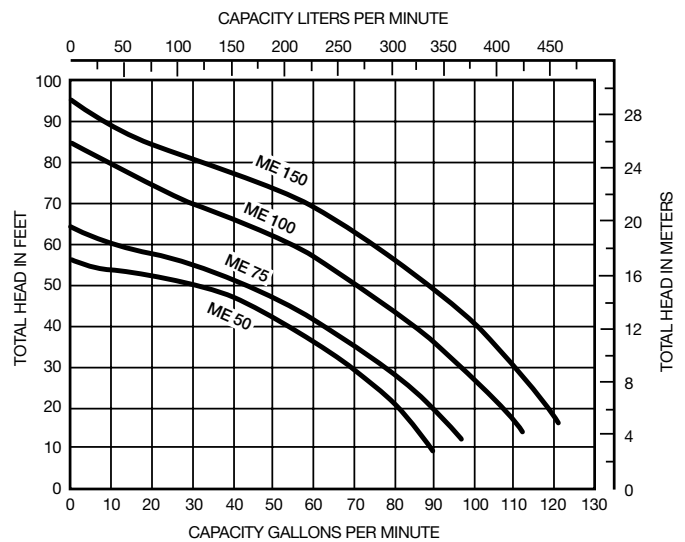

## MW Series Dimensions

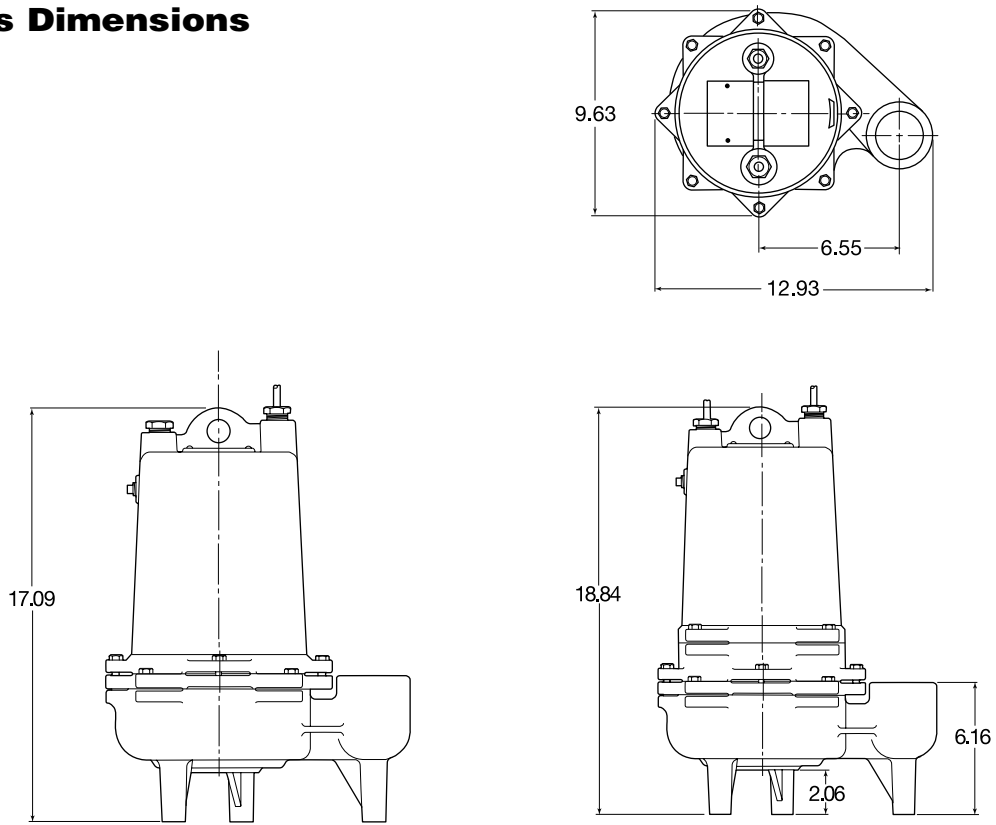

## MW Performance Curve

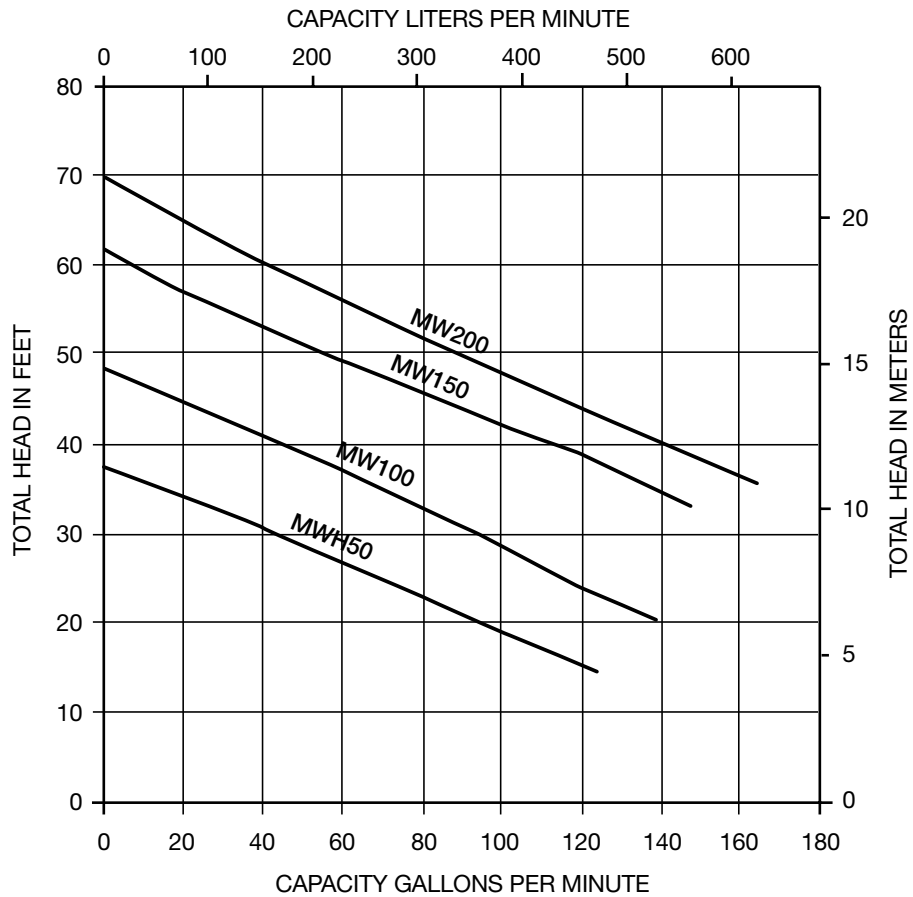

# Motor Data Chart

H.P.	Speed	Volts	Phase	Stack Height	Winding Resistance In Ohms			Max. Amps	Locked Rotor Amps		
					Main Black To White	Start - 1Ø	White To Red				
						Brn. To Brn. Or Purple Black To Red - 3Ø					
<b>ME Series</b>											
1/2	3450	115	1	1-5/8	.9/.8	14.7	-	12.1	29.6		
		208				6.7		16.5			
		230			9.8	19.7		6.0	15.0		
		208/230	3		11.3	11.3	11.3	3.5/3.2	12.8		
		460			45.4	45.4	45.4	1.6	6.4		
		575			71.0	71.0	71.0	1.3	5.1		
3/4	3450	115	1	2-1/4	.85	4.9	-	13.8	30.4		
		208/230			4.5	12.0		7.6/6.9	16.2		
		208/230	3	2	7.6	7.6	7.6	5.2/4.7	20.2		
		460			30.1	30.1	30.1	2.3	10.1		
		575			47.0	47.0	47.0	1.9	8.1		
1	3450	208	1	2-3/4			-	10.3	21.0		
		230			3.0/2.6	16/14		9.3	19.0		
		208/230	3	2-1/2	5.3	5.3	5.3	6.6/6.0	29.0		
		460			21.2	21.2	21.2	3.0	14.5		
		575			33.1	33.1	33.1	2.4	11.6		
1-1/2	3450	208	1	2-3/4			-	14.1			
		230			2.4	12.0		12.8	23.0		
		208/230	3		4.5	4.5	4.5	8.8/8.0	30.0		
		460			16.0	16.0	16.0	4.0	15.0		
		575			25.0	25.0	25.0	3.2	12.0		
<b>MW Series</b>											
1/2	3450	208	1	2-1/4	4.5	12.0	-	7.6	16.2		
		230			6.9						
		208	3	2	7.6	7.6	7.6	5.2	20.2		
		230			30.1	30.1	30.1	4.7			
		460			47.0	47.0	47.0	2.3		10.1	
1	3450	575	1	2-3/4	2.2	11.5	-	1.9	8.1		
		208			2.8	15.0		10.3	21.0		
		230	3	2-1/2	5.3	5.3	5.3	9.3	19.0		
		208			6.6	6.0	29.0				
		460			21.2	21.2	21.2	3.0	14.5		
1-1/2	3450	575	3	2-3/4	33.1	33.1	33.1	2.4	11.6		
		208			1	2.1	9.3	-	14.8	39.9	
		230				1.6	7.4		12.8	33.4	
		2	3450		208	3	4.5	4.5	4.5	7.7	30.0
					230		18.0	18.0	18.0	7.0	
460	28.0			28.0	28.0		3.5	15.0			
2	3450	575	1	2-3/4	2.1	9.3	-	2.8	12.0		
		230			1.6	7.4		13.1	33.4		
		208	3		4.5	4.5	4.5	8.5	30.0		
		230			4.5	4.5		7.7			
		460			18.0	18.0		18.0		3.9	15.0
575	28.0	28.0	28.0	3.1	12.0						



## Limited Warranty

F.E. MYERS warrants to the original consumer purchaser ("Purchaser" or "You") of the products listed below, that they will be free from defects in material and workmanship for the Warranty Period shown below.

Product	Warranty Period
Jet pumps, small centrifugal pumps, submersible pumps and related accessories	whichever occurs first: 12 months from date of original installation, or 18 months from date of manufacture
Fibrewound Tanks	5 years from date of original installation
Steel Pressure Tanks	5 years from date of original installation
Sump/Sewage/Effluent Products	12 months from date of original installation, or 24 months from date of manufacture

Our warranty will not apply to any product that, in our sole judgement, has been subject to negligence, misapplication, improper installation, or improper maintenance. Without limiting the foregoing, operating a three phase motor with single phase power through a phase converter will void the warranty. Note also that three phase motors must be protected by three-leg, ambient compensated, extra-quick trip overload relays of the recommended size or the warranty is void.

Your only remedy, and F.E. MYERS's only duty, is that F.E. MYERS repair or replace defective products (at F.E. MYERS's choice). You must pay all labor and shipping charges associated with this warranty and must request warranty service through the installing dealer as soon as a problem is discovered. No request for service will be accepted if received after the Warranty Period has expired. This warranty is not transferable.

F.E. MYERS SHALL NOT BE LIABLE FOR ANY CONSEQUENTIAL, INCIDENTAL, OR CONTINGENT DAMAGES WHATSOEVER.

THE FOREGOING LIMITED WARRANTIES ARE EXCLUSIVE AND IN LIEU OF ALL OTHER EXPRESS AND IMPLIED WARRANTIES, INCLUDING BUT NOT LIMITED TO IMPLIED WARRANTIES OF MERCHANTABILITY AND FITNESS FOR A PARTICULAR PURPOSE. THE FOREGOING LIMITED WARRANTIES SHALL NOT EXTEND BEYOND THE DURATION PROVIDED HEREIN.

Some states do not allow the exclusion or limitation of incidental or consequential damages or limitations on the duration of an implied warranty, so the above limitations or exclusions may not apply to You. This warranty gives You specific legal rights and You may also have other rights which vary from state to state.

This Limited Warranty is effective June 1, 2011 and replaces all undated warranties and warranties dated before June 1, 2011.

### **F.E. MYERS**

**293 Wright Street, Delavan, WI 53115**

**Phone: 888-987-8677 • Fax: 800-426-9446 • [www.femyers.com](http://www.femyers.com)**

**In Canada: P. O. Box 9138, 269 Trillium Dr., Kitchener, Ontario N2G 4WS**

**Phone: 519-748-5470 • Fax: 888-606-5484**

This page intentionally left blank

This page intentionally left blank

